

ALFA ROMEO

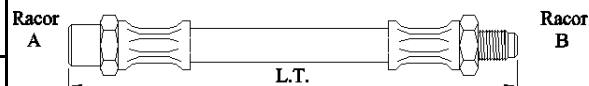

	Fecha Date	Eje Axle	Referencia Reference	Racor A Fitting	Racor B Fitting	LT	
33 >1989							
Todos modelos	>89	D	64079	187	223	450	
		T	63261	186	187	364	
33 1990>94							
Todos modelos (- TD)	90>94	D	64235	187	223	476	
Todos los modelos	90>94	D	64127	187	223	465	
Todos los modelos	86>	TI	63198	186	186	340	
Todos los modelos (+ABS)	90>94	TD	63197	223	227	354	
4X4							
Todos modelos	>89	D	64079	187	223	450	
		T	63197	223	227	354	
75 - 90							
ALFA 75, 90	84>	D	64107	223	223	450	
		T	62073	223	223	275	
145/146							
Todos Modelos	9/94>12/96	D	64145	187	191	440	
Todos Modelos		I	62077	191	191	241	
Todos Modelos		T	61196	187	191	185	

ALFA ROMEO

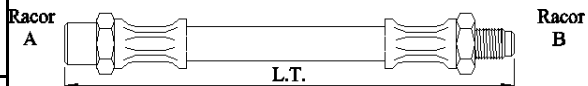

Fecha Date	Eje Axle	Referencia Reference	Racor A Fitting	Racor B Fitting	LT
------------	----------	----------------------	-----------------	-----------------	----

145/146

Todos Modelos

97>

D

64150

187

191

430

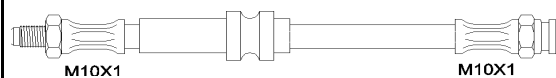

Todos Modelos

97>

T

61196

187

191

185



145 (930) 1.4ie 16v,
1.6ie, 1.7ie16v, 1.9JTD,
2.016V

97>

D

64091

187

191

412

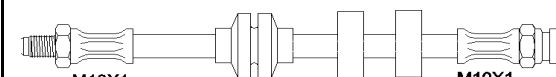

147

Todos Modelos
(Except. 3.2 GTA)

01/2001>

D

63259

187

191

425

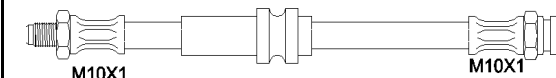

T

64008

187

191

435

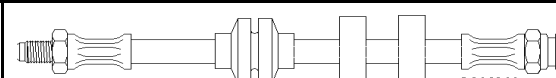

3.2 GTA

02/2003>

D

63252

191

191

385

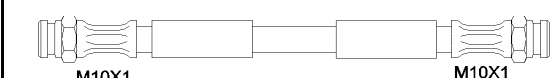

T

64008

187

191

435

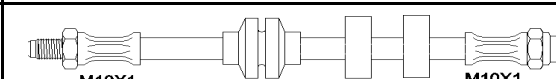

155

Todos modelos

11/91>12/97

D

64145

187

191

440

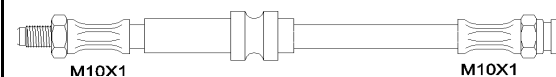

Todos BZ (+ABS)

11/91>94

T

61196

187

191

185

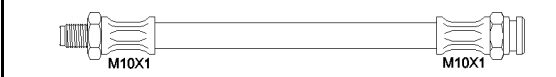

Todos BZ (-ABS)

11/91>94

T

62085

187

191

210



Todos BZ

95>12/97

T

61196

187

191

185



Todos DS

11/91>12/97

T

62085

187

191

210

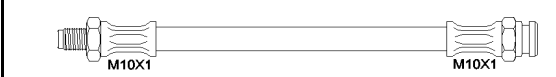

156

Todos Modelos

01/2001>

D

63259

187

191

425

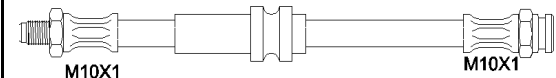

T

64008

187

191

435

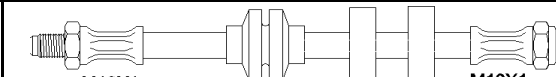

ALFA ROMEO

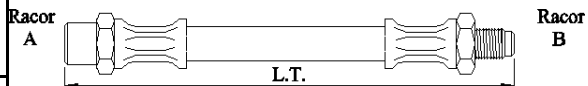

	Fecha Date	Eje Axle	Referencia Reference	Racor A Fitting	Racor B Fitting	LT	
164							
2.0, 3.0, 2.5 TD	06/87>09/98	D	63252	191	191	385	
V6 Turbo	03/91>09/98	D	63253	191	191	335	
2.0, 3.0, 2.5 TD (-ABS)	06/87>09/98	T	63259	187	191	425	
166							
2.0i 16V, 2.0i V6, 2.5i V6 24V, 3.0i V6 24V	99>	D	65052	187	191	587	
		T	64094	187	191	460	
166							
2.4 TD JTD	99>	D	65052	187	191	587	
		T	64094	187	191	460	
ALFASUD							
Alfasud Todos (Except. Sprint)	80>84	D	63095	186	187	310	
	80>83	T	64108	186	187	400	
	83>84	T	63261	186	187	364	
ALFASUD SPRINT							
Alfasud Sprint	07/83>03/89	D	64079	187	223	450	
	03/83>09/86	T	63261	186	187	364	
	10/86>03/89	T	63197	223	227	354	

ALFA ROMEO

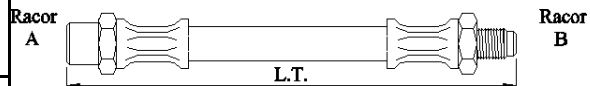

	Fecha Date	Eje Axle	Referencia Reference	Racor A Fitting	Racor B Fitting	LT	
ALFETTA							
Alfetta	05/73>04/83	D	63022	223	223	370	
Alfetta	05/83>09/85	D	64107	223	223	450	
Alfetta	05/73>04/83	T	63023	223	223	387	
Alfetta	1983>85		62023	223	223	275	
ARNA							
Todos	83>86	D	64079	187	223	450	
		T	63261	186	187	364	
GIULIA							
Todos	01/70>79		63024	117	117	390	
ALFA Spider Tipo 916			63025	044	117	380	
GIULIETTA							
Todos	77>04/83	D	63022	223	223	370	
Todos	05/83>86	D	64107	223	223	450	
	77>04/83	T	63023	223	223	387	
Todos	05/83>86	T	62023	223	223	275	
GT							
1.8 TS, 1.9 JTD	11/03>	D	63259	187	191	425	

ALFA ROMEO

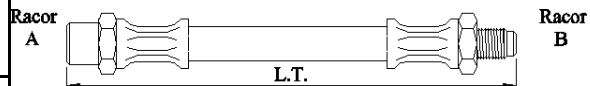

	Fecha Date	Eje Axle	Referencia Reference	Racor A Fitting	Racor B Fitting	LT	
GT							
1.8 TS, 1.9 JTD	11/03>	T	64177			462	
2.0 JTS	11/03>	D	63259	187	191	425	
3.2 GTA	11/03>	T	64177			462	
GTV							
Todos	>01/81	D	63022	223	223	370	
		T	63023	223	223	387	
Todos	02/81>	D	64107	223	223	450	
		T	62023	223	223	275	
2.0 TS 16V, 2.0 Turbo V6	95>98	D	64145	187	191	440	
Lado classis	95>98	T	62077	191	191	241	
Lado rueda	95>98	T	63089	187	191	337	
Todos modelos	98>	T	63089	187	191	337	
MITO							
1.4	09/08>	T	64179			165	
SPIDER							
Todos modelos	09/94>98	D	64145	187	191	440	
Lado classis	95>98	T	62077	191	191	241	
Lado rueda	95>98	T	63089	187	191	337	

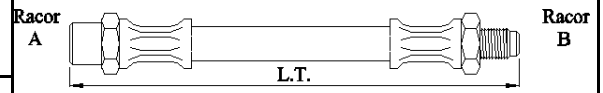

Fecha Date	Eje Axle	Referencia Reference	Racor A Fitting	Racor B Fitting	LT
------------	----------	----------------------	-----------------	-----------------	----

80

<i>AUDI 80 Todos</i>	84>87	D	63147	186	187	343	
		TD	62076	186	186	225	
		TI	62048	186	186	210	
<i>Todos Modelos (Excepto 2.3 20V)</i>	1987>92	D	63147	186	187	343	
<i>2.3 20V</i>	1987>92	D	64108	186	187	400	
<i>Chasis 8AL038657> lado chasis</i>	1990>96	D	63316	253	253	317	
<i>Chasis 8AL038657> lado rueda</i>	1990>96	D	61200	186	187	185	
<i>Trasero Izd. Lado chasis</i>	1987>92	TI	62076	186	186	225	
<i>Trasero Der. Lado chasis</i>	1987>92	TD	61034	186	186	187	
<i>Trasero con corrector lado rueda</i>	1987>92	TI	62075	186	186	235	
<i>Lado chasis</i>	1992>96		62104	253	253	220	

80 QUATTRO

<i>Todos modelos</i>	1983>87	D	63147	186	187	343	
<i>Chassis >85D250000</i>		T	63147	186	187	343	
<i>Chassis 85D250001></i>		T	63094	186	187	270	
<i>Todos Modelos (Excepto 2.3 20V) Chassis >8AL030000</i>	1987>96	D	63147	186	187	343	
<i>8AL030001> lado chasis</i>	1987>96	D	63316	253	253	317	

AUDI

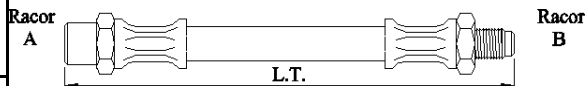

Fecha Date	Eje Axle	Referencia Reference	Racor A Fitting	Racor B Fitting	LT
------------	----------	----------------------	-----------------	-----------------	----

80 QUATTRO

8AL030001 > lado rueda	1987>96	D	61200	186	187	185	
2.3 20V Chassis >8AL030000	1987>96	D	64108	186	187	400	
Chasis 8AL030001 > lado chasis	1987>96	D	63316	253	253	317	
Chasis 8AL030001 > lado rueda	1987>96	D	61200	186	187	185	
Todos modelos	1987>92	T	62035	186	187	275	
Todos modelos	1992>94	T	62070	186	187	244	
Todos modelos	1995>96	T	62102	253	253	195	
Todos modelos	1995>96	T	62070	186	187	244	

COUPÉ

Todos modelos	1981>88	D	63147	186	187	343	
con freno de Tambor	1981>88	TI	62076	186	186	225	
con freno de Tambor	1981>88	TD	62048	186	186	210	
con freno de Disco	1981>88	T	61200	186	187	185	
Todos Modelos (Excepto 2.3 20V) Chassis >88L003792	1989>94	D	63147	186	187	343	
Lado chasis Chassis 88L003793 >	1989>94	D	63316	253	253	317	
Lado rueda Chassis 88L003793 >	1989>94	D	61200	186	187	185	
2.3 20V	1989>94	D	64108	186	187	400	

AUDI

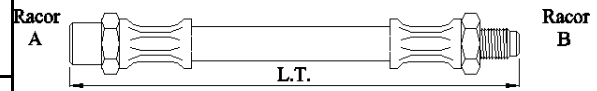

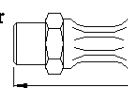
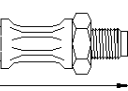



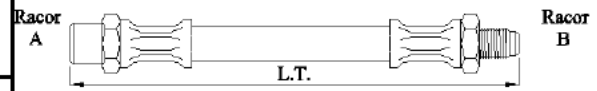

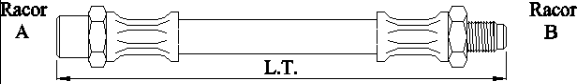
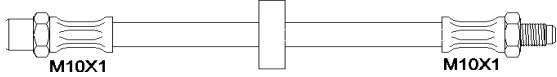
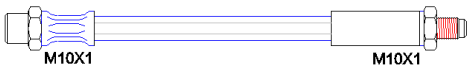
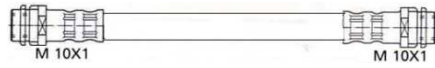

	AUDI						Racor A  L.T.  Racor B	
	Fecha Date	Eje Axle	Referencia Reference	Racor A Fitting	Racor B Fitting	LT		
COUPÉ								
Lado chasis	1995>96	D	63316	253	253	317		
Lado rueda	1995>96	D	61200	186	187	185		
Lado chasis	1989>96	TI	62076	186	186	225		
Lado chasis	1989>96	TD	61034	186	186	187		
Lado rueda	1989>96	T	61200	186	187	185		
90								
Todos modelos	85>87	D	63147	186	187	343		
		TI	62076	186	186	225		
		TD	61034	186	186	187		
Todos modelos (excep 2.3 20V)	87>92	D	63147	186	187	343		
2.3 20V		D	64108	186	187	400		
lado chasis		TI	62076	186	186	225		
lado chasis		TD	61034	186	186	187		
corrector (lado rueda)		T	61200	186	187	185		
100								
Todos modelos	>1989	D	63212	186	186	310		
		T	61034	186	186	187		

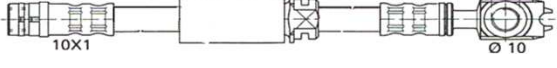
AUDI

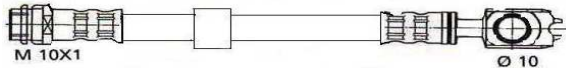
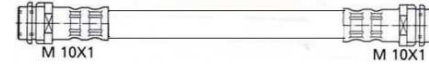
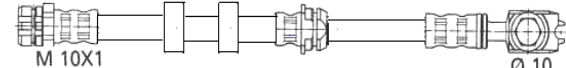
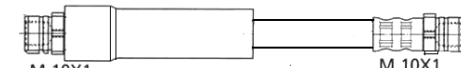

	Fecha Date	Eje Axle	Referencia Reference	Racor A Fitting	Racor B Fitting	LT	
100							
Todos modelos	1990>94	D	63316	253	253	317	
Todos freno tambor		T	61034	186	186	187	
Todos freno disco		T	62214	186	187	242	
200							
2.1, 2.2,	1979>83	D	63219	186	187	350	
		T	62048	186	186	210	
2.1, 2.2,	1983>86	D	63211	186	186	330	
		T	62048	186	186	210	
2.1, 2.2	1986>88	D	64108	186	187	400	
		T	63219	186	187	350	
2.3	1985>86	D	63211	186	186	330	
		T	63219	186	187	350	
2.3	1986>91	D	64108	186	187	400	
		T	62214	186	187	242	
200 Quattro							
Quattro 2.1, 2.2, 2.3	1984>86	D	63211	186	186	330	
		T	62214	186	187	242	

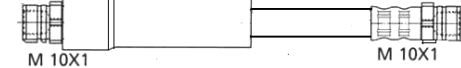
		AUDI						
Fecha Date	Eje Axle	Referencia Reference	Racor A Fitting	Racor B Fitting	LT			
200 Quattro								
Quattro 2.1, 2.2	1986>88	D	64108	186	187	400		
		T	62214	186	187	242		
A1 (8X1)								
1.2 TFSI, 1.4 TFSI, 1.6 TDI	05/10>	T	62174	274	274	168		
2.0 TDI	09/11>	T	62174	274	274	168		
A2								
Delantero	03/01>07/05	D	65127	253	275	525		
Delantero	03/01>07/05	D	64011	274	277	407		
Trasero	03/2001>02	T	62104	253	274	220		
Trasero	04/2002>	T	62013	274	274	220		
A3								
1.6, 1.8, 1.9, 2.0,	1996>	D	64159	274	275	435		
		T	62174	274	274	168		
1.6, 1.8, 1.9, 2.0,	2003>	D	65034	253	275	572		
1.6, 1.8, 1.9, 2.0,	2003>	T	62014	253	253	260		
3.2 Sport	2004	D	65035	253	253	545		
3.2 Sport	2004	T	62014	253	253	260		

AUDI

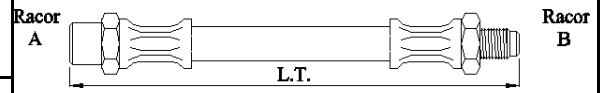



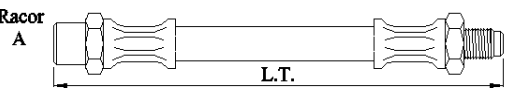
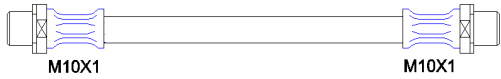
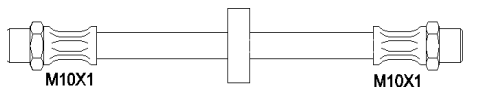
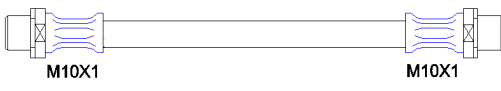
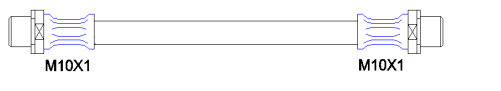
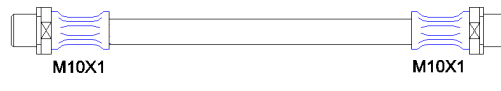
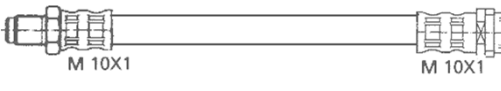
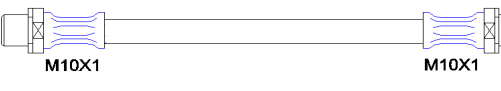
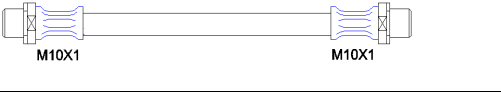
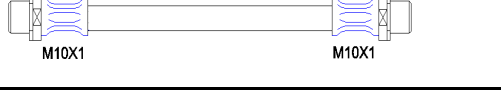
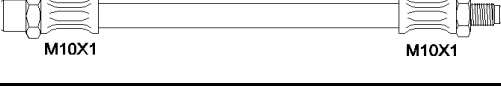
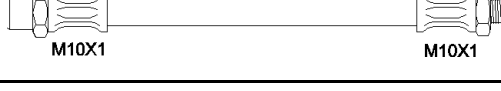
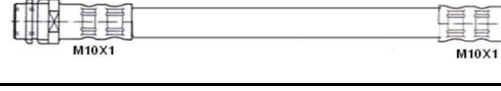
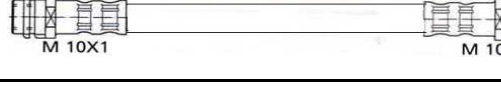
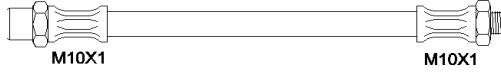

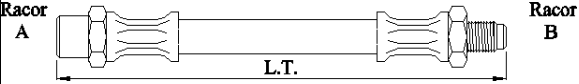
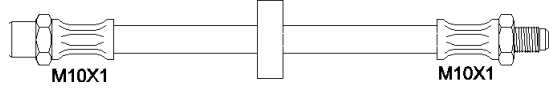
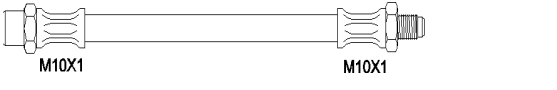
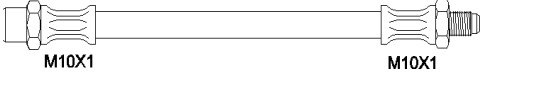
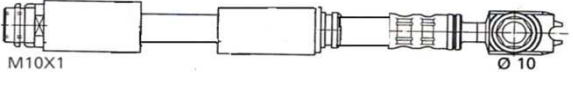
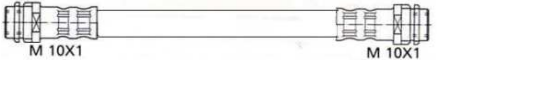
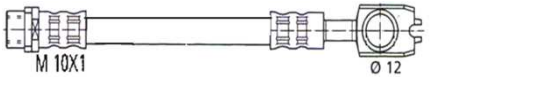
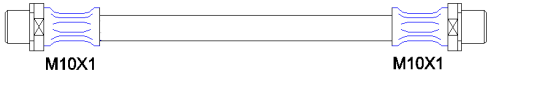
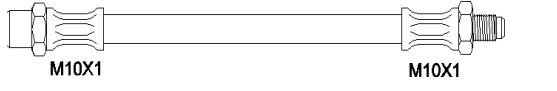
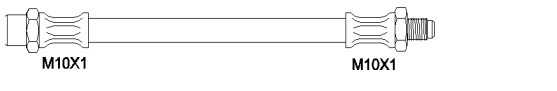
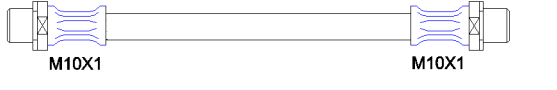
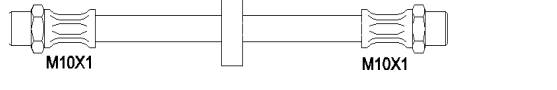
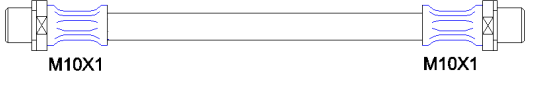
	AUDI						Racor A Racor B	
	Fecha Date	Eje Axle	Referencia Reference	Racor A Fitting	Racor B Fitting	LT		
A3								
Quattro 1.8, 1.9 >Chassis 8L3045001	>2003	D	65036	253	275	580		
	>2003	D	65037	274	275	575		
	>2003	T	62174	274	274	168		
Quattro 2.0	2004>06	D	65034	253	275	572		
		T	62014	253	253	260		
		T	62174	274	274	168		
A4								
Todos modelos	1995>01	D	63316	253	253	317		
Todos modelos		I	62100	253	253	202		
>Chassis 8DV160000	1995>	T	62074	186	187	225		
Chassis 8DV160001>	>2001	T	62015	253	278	255		
	2001>	T	62016	253	277	280		
Quattro		D	63316	253	253	317		
Todos modelos		D	64065	274	244	255		
Lado chassis		T	62214	186	187	242		
Lado caliper		T	62102	253	253	195		



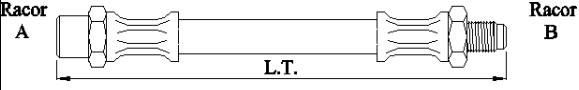
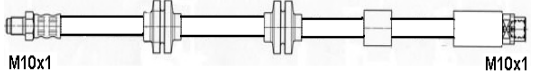
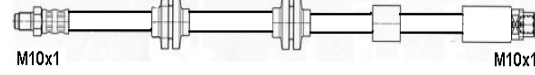

		AUDI						
<i>Fecha Date</i>	<i>Eje Axle</i>	<i>Referencia Reference</i>	<i>Racor A Fitting</i>	<i>Racor B Fitting</i>	<i>LT</i>			
A6								
<i>Todos modelos</i>	94>97	D	62019	253	253	292		
		T	62048	186	186	210		
<i>Todos modelos</i>	1997>2004	D	63316	253	253	317		
		T	62102	253	253	195		
<i>Todos modelos</i>	2004>	D	63026	253	253	340		
		T	63027	187	253	350		
A8								
<i>Todos modelos</i>	1997>	D	63028	253	253	386		
<i>Todos modelos</i>	>2003	I	62102	253	253	195		
	2003>	I	62100	253	253	202		
<i>Todos modelos</i>	>2003	T	62023	186	187	290		
	2003>	T	63212	186	187	310		
Q7								
<i>Todos modelos</i>	2006>	D	65038	274	274	542		
<i>Todos modelos</i>	2006>	T	64012	274	274	425		
QUATTRO								
<i>Todos modelos</i>	1980>86	D	63261	186	187	360		

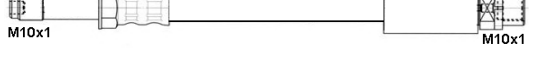
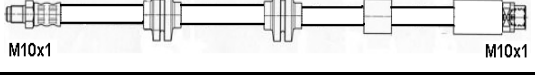
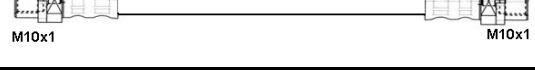
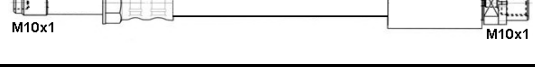
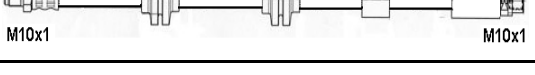
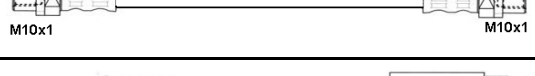
		AUDI						
	Fecha Date	Eje Axle	Referencia Reference	Racor A Fitting	Racor B Fitting	LT		
QUATTRO								
<i>Todos modelos</i>	1987>	D	64108	186	187	400		
	1980>	T	62035	186	187	275		
	1999>	T	63212	186	187	310		
S3 QUATTRO								
<i>Todos modelos</i>		D	65037	274	275	575		
		T	62174	274	274	168		
S4 CABRIO QUATTRO								
4.2	2003>05	T	62016	253	277	280		
S4 QUATTRO								
<i>Todos modelos</i>	1997>	D	63316	253	253	317		
	1997>	I	63212	186	187	310		
	1997>	T	62214	186	187	242		
S6 PLUS QUATTRO								
<i>Todos modelos</i>		D	62019	253	253	292		
		T	62048	186	186	210		
S6 QUATTRO								
<i>Todos modelos</i>	1994>98	D	62019	253	253	292		

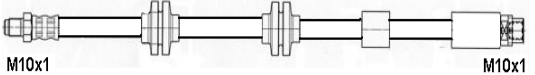
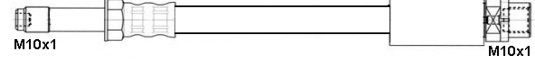
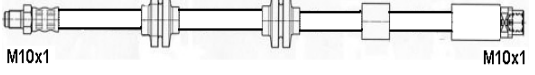
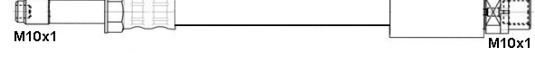
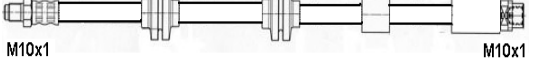
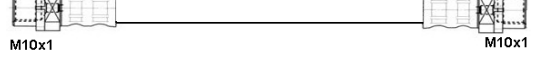
		AUDI						
	<i>Fecha Date</i>	<i>Eje Axle</i>	<i>Referencia Reference</i>	<i>Racor A Fitting</i>	<i>Racor B Fitting</i>	<i>LT</i>		
S6 QUATTRO								
<i>Todos modelos</i>	1999>	D	63316	253	253	317		
	1994>98	T	62048	186	186	210		
	1999>	T	63029	253	277	325		
S8 QUATTRO								
<i>Todos modelos</i>	1996>	D	63028	253	253	386		
<i>Todos modelos</i>	1996>	T	62023	186	187	290		
TT (8J3)								
<i>3.2 VR6 quattro</i>	10/06>	T	62174	274	274	168		
TT (8N3)								
<i>1.8T, 1.8 T quattro</i>	10/98>06/06	D	65037	274	275	575		
	10/98>07/06	T	62174	274	274	168		
	10/98>06/06	TI	63124			335		
TT (8N3)								
<i>1.8T, 1.8 T quattro</i>	10/98>06/06	TD	63125			335		
<i>3.2 VR6 quattro</i>	07/03>06/06	T	62174	274	274	168		
	07/03>06/06	TI	63124			335		
	07/03>06/06	TD	63125			335		

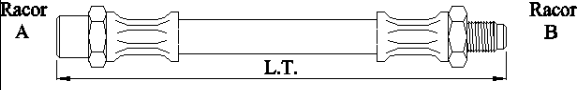
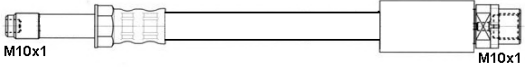
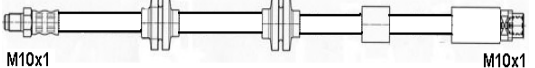
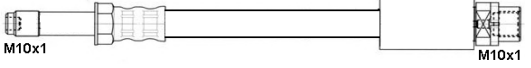
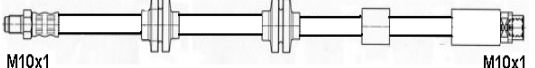
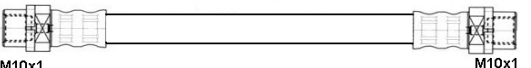
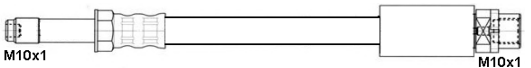
		AUDI						
Fecha Date	Eje Axle	Referencia Reference	Racor A Fitting	Racor B Fitting	LT			
TT Roadster (8N9)								
1.8T, 1.8 T quattro	10/99>06/06	D	65037	274	275	575		
	10/99>06/06	T	62174	274	274	168		
	10/99>06/06	TI	63124			335		
	10/99>06/06	TD	63125			335		
3.2 VR6 quattro	07/03>06/06	T	62174	274	274	168		
	07/03>06/06	TI	63124			335		
	07/03>06/06	TD	63125			335		
AUDI V8								
V8 Todos modelos	1988>93	T	62214	186	187	242		
AUTO-BIANCHI								
A112, Y10								
A112 Todos modelos	1969>85	D	62009	051	132	312		
		T	62008	051	132	280		
Y10	1985>95	D	63226	187	191	365		
		T	62085	187	191	210		
Y10 Turbo 4X4	1986>89	D	63262	187	191	397		
		T	62085	187	191	210		

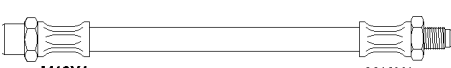
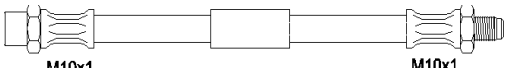
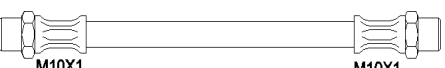

		BMW						
	Fecha Date	Eje Axle	Referencia Reference	Racor A Fitting	Racor B Fitting	LT		
SERIE 1 (E81, E87)								
116d	03/09>	D	65050			548		
116i, 118d, 118i, 120d, 120i	09/04>	D	65050			548		
		E	62122			205		
		T	62123			265		
123d	10/07>	D	65050			548		
		E	62122			205		
		T	62123			265		
130i	03/05>	D	65050			548		
		T	62122			205		
		T	62123			265		
SERIE1 Convert. (E88)								
118d, 123d	09/08>	D	65050			548		
		T	62123			265		
118i	03/08>	D	65050			548		
		T	62123			265		
120d, 123d, 125i, 135i	03/08>	D	65050			548		
		T	62122			205		



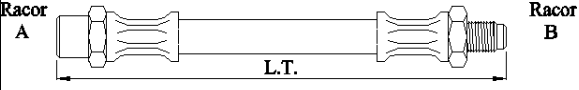
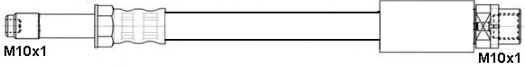
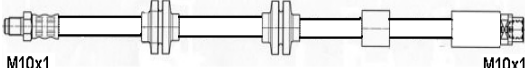
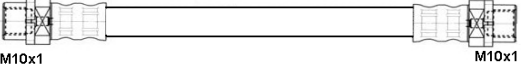
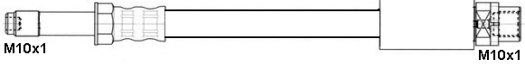
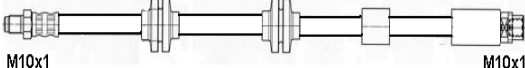
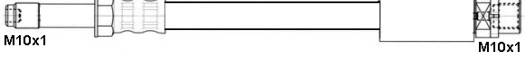
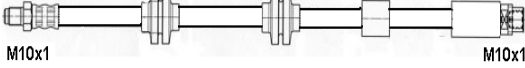
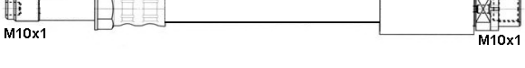
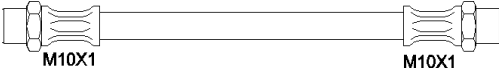
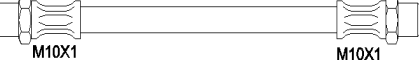
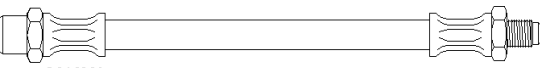
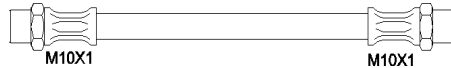
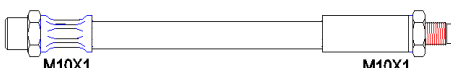
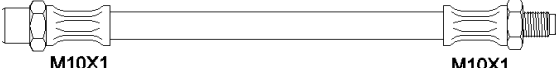

		BMW						
Fecha Date	Eje Axle	Referencia Reference	Racor A Fitting	Racor B Fitting	LT			
SERIE1 Convert. (E88)								
120d, 123d, 125i, 135i	03/08>	T	62123			265		
SERIE 1 Coupe(E82)								
118d, 120i	09/09>	D	65050			548		
		T	62123			265		
120d, 123d, 125i, 135i	10/07>	D	65050			548		
		T	62122			205		
		T	62123			265		
SERIE 3 (E21)								
315,316,318,318,i, 320,320i,323 Lado rueda Lado caliper	1975>83	D	63212	186	186	310		
		T	62076	186	186	225		
		T	62074	186	187	225		
SERIE 3 (E30)								
316i, 318i,320i,324D Lado rueda Lado caliper	1983>91	D	63213	186	187	330		
		T	62076	186	186	225		
		T	62074	186	187	225		
SERIE 3 (E36)								
316i, 318i, 318D, 320i, 325i, 325D	1991>99	D	64115	186	187	445		

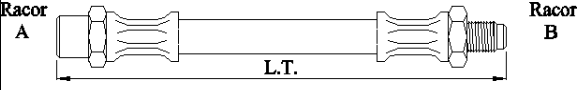
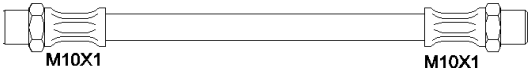

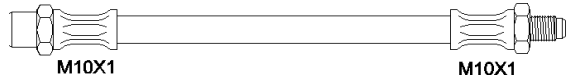
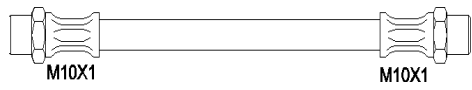
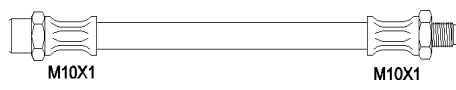
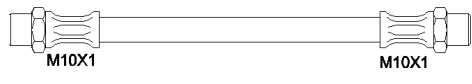
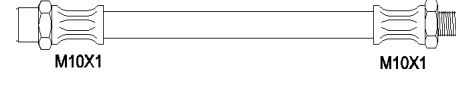
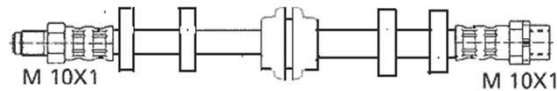
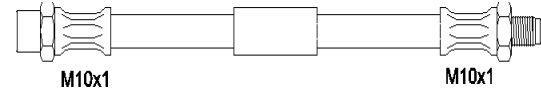
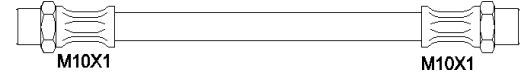
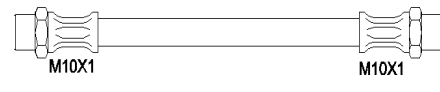
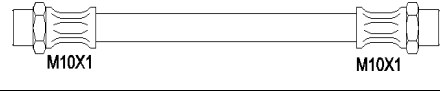
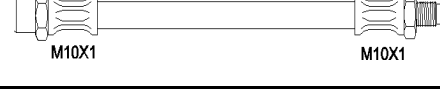
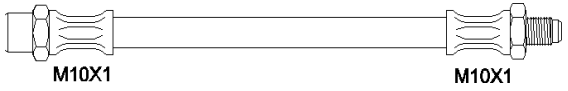

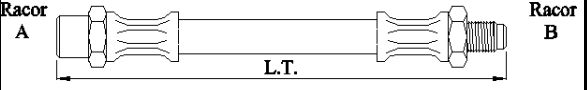
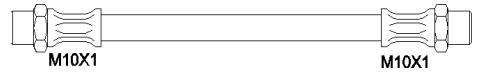
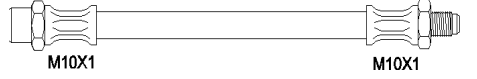

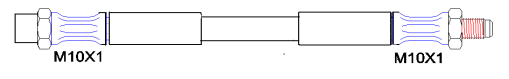
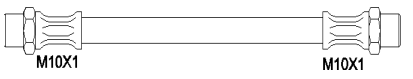
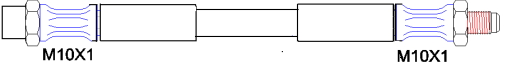
		BMW						
Fecha Date	Eje Axle	Referencia Reference	Racor A Fitting	Racor B Fitting	LT			
SERIE 3 (E36)								
Lado rueda		T	62176	186	186	258		
Lado caliper		T	62074	186	187	225		
Todos modelos (ABS, ASC) (-316, 318 TDS)	1991>99	T	65039	244	253	504		
SERIE 3 (E46)								
Todos modelos	1998>	D	64013	244	253	450		
		T	65039	244	253	504		
SERIE 3 (E90)								
316d	07/09>	D	65050			548		
		T	62122			205		
		T	62123			265		
316i	02/06>	D	65050			548		
		T	62122			205		
		T	62123			265		
318d, 318i, 330d	09/05>	D	65050			548		
		T	62122			205		
		T	62123			265		
320i	05/06>	D	65050			548		

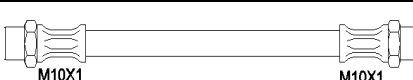
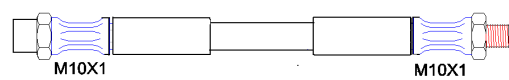
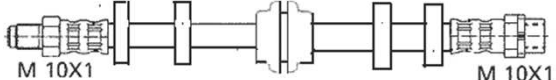
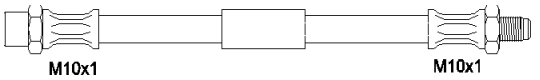
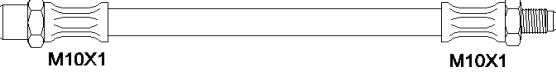
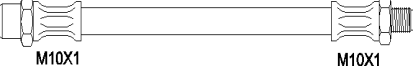
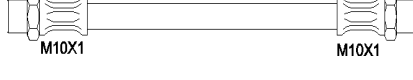
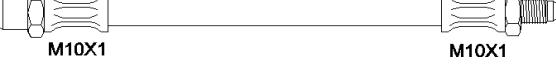
		BMW						
	Fecha Date	Eje Axle	Referencia Reference	Racor A Fitting	Racor B Fitting	LT		
SERIE 3 (E90)								
320i	05/06>	T	62123			265		
320d, 325i, 335i	01/05>	D	65050			548		
		T	62122			205		
		T	62123			265		
320d, 335i	09/07>	D	65050			548		
		T	62123			265		
323i	04/06>06/07	D	65050			548		
		T	62123			265		
SERIE 5 (E12)								
Todos modelos	1972>81	D	63212	186	186	310		
Todos modelos		T	62076	186	186	225		
SERIE 5 (E28)								
518, 518i, 520i, 524TD	1980>86	D	64109	186	187	470		
Lado rueda		T	62076	186	186	225		
Lado caliper		T	62214	186	187	244		
SERIE 5 (E34)								
Todos modelos	1989>95	D	64109	186	187	470		

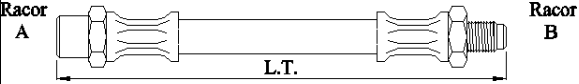
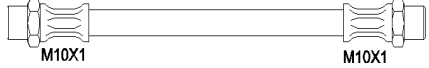
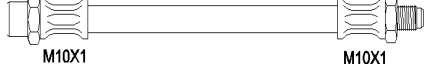
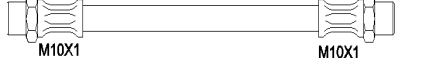
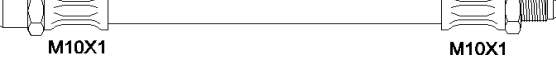
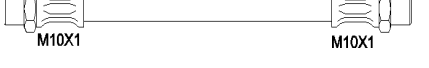

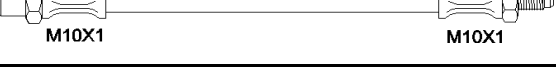
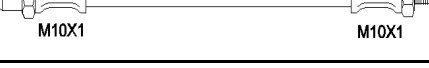
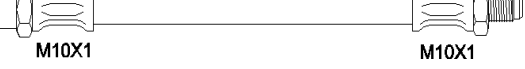

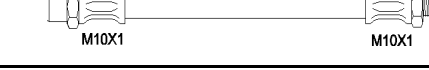
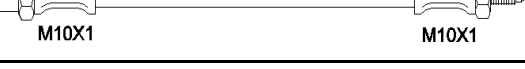
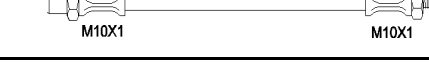

		BMW						
	<i>Fecha Date</i>	<i>Eje Axle</i>	<i>Referencia Reference</i>	<i>Racor A Fitting</i>	<i>Racor B Fitting</i>	<i>LT</i>		
SERIE 5 (E34)								
<i>Lado rueda</i>	1989>95	T	62076	186	186	225		
<i>Lado caliper</i>	1989>95	T	62074	186	187	225		
SERIE 5 (E39)								
<i>Todos modelos</i>	1995>	D	64212	186	187	435		
<i>Todos modelos</i>		T	63343	244	253	320		
<i>Todos modelos Touring</i>		T	63344	186	187	300		
SERIE 5 (E60)								
<i>Todos modelos</i>	07/2003>	D	65040	187	253	580		
		T	63213	186	187	330		
SERIE 6 (E24)								
<i>628 CSI</i>	1979>82	D	63212	186	186	310		
		T	62076	186	186	225		
<i>628 CSI</i>	1982>87	D	64115	186	187	445		
<i>Lado chasis</i>		T	62076	186	186	225		
<i>Lado rueda</i>		T	62074	186	187	225		
<i>630 CS, 633 CSI</i>	1975>81	D	63212	186	186	310		
		T	62076	186	186	225		

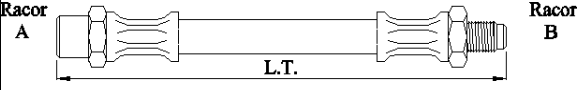
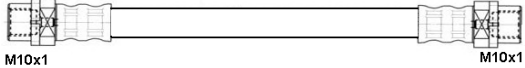
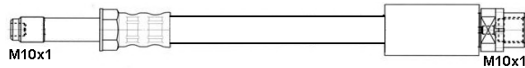
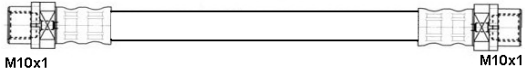
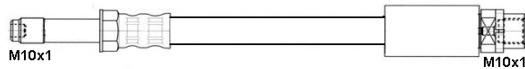
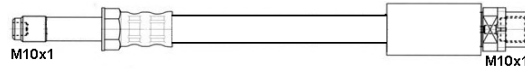
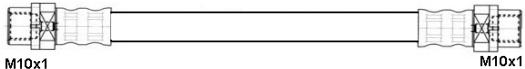
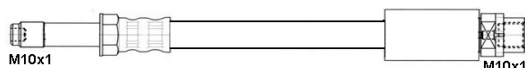
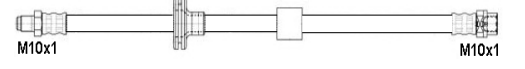
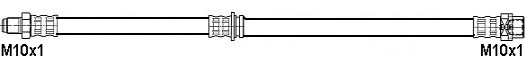
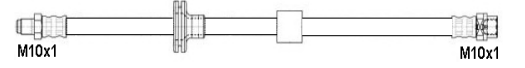
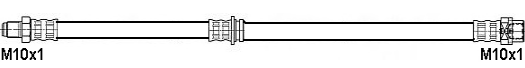
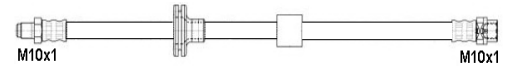
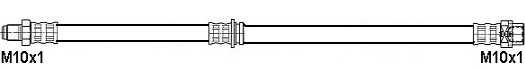
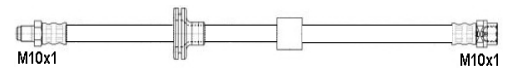
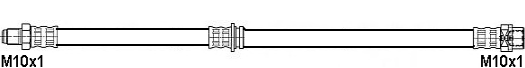
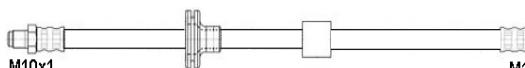

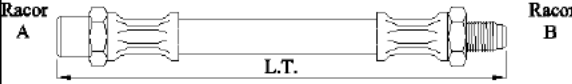
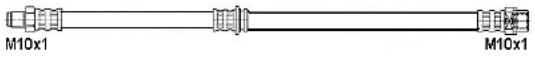
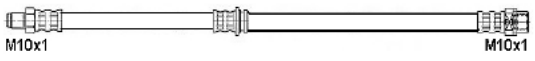
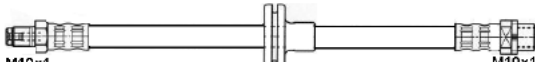

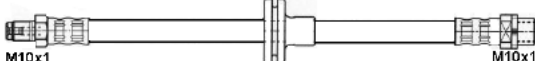

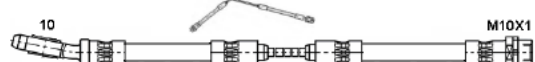
		BMW						
Fecha Date	Eje Axle	Referencia Reference	Racor A Fitting	Racor B Fitting	LT			
SERIE 6 (E24)								
635 CSI	1977>82	D	63212	186	186	310		
		T	62076	186	186	225		
635 CSI	1982>89	D	64115	186	187	445		
Lado chasis		T	62076	186	186	225		
Lado rueda		T	62074	186	187	225		
M635 CSI Lado chasis	1983>89	T	62076	186	186	225		
M635 CSI Lado rueda		T	62074	186	187	225		
SERIE 6 (E63)								
Coupe 645 CI	2004>	D	65102	187	253	580		
		T	63213	186	187	330		
SERIE 7 (E23)								
Todos modelos	1977>81	D	63212	186	186	310		
		T	62076	186	186	225		
Lado chasis	1981>86	T	62076	186	186	225		
Lado rueda	1981>86	T	62074	186	187	225		
SERIE 7 (E32)								
Todos modelos	1985>94	D	64115	186	187	445		

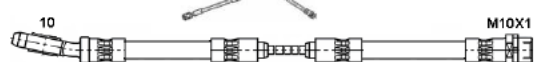
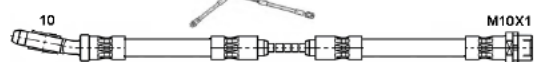
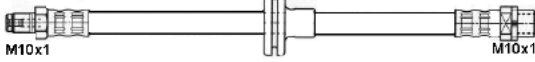
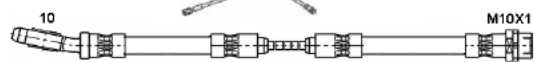
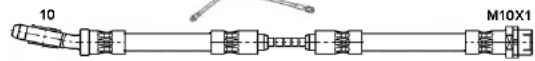
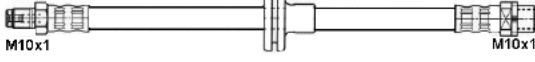
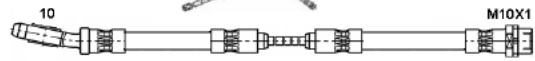

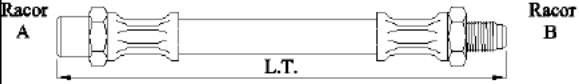

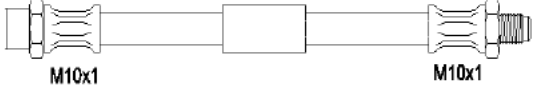
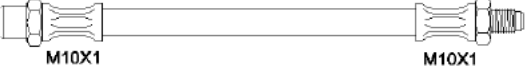
		BMW						
Fecha Date	Eje Axle	Referencia Reference	Racor A Fitting	Racor B Fitting	LT			
SERIE 7 (E32)								
Lado chasis	1985>94	T	62076	186	186	225		
Lado rueda		T	62074	186	187	225		
SERIE 7 (E38)								
Todos modelos ABS	1993>	D	63035	187	253	380		
		T	63344	186	187	300		
Todos modelos ABS (-ASC+T)	1993>	D	61197	186	186	120		
		T	63344	186	187	300		
ASC - DSC	1993>	D	63035	187	253	380		
Lado chasis		T	61197	186	186	120		
Lado rueda		T	63344	186	187	300		
SERIE 7 (E65, E66)								
Todos modelos	2001>	D	65102	187	253	580		
		T	63213	186	187	330		
840 I	1992>93	D	64115	186	187	445		
		T	62074	186	187	225		
Lado chasis	1993>96	D	61197	186	186	120		
Lado rueda		D	64115	186	187	445		

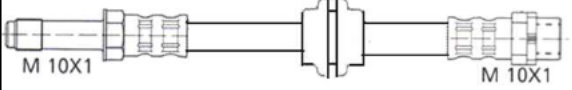
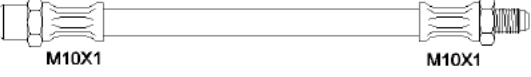
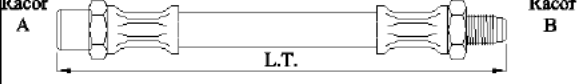

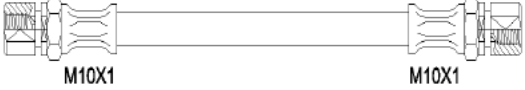

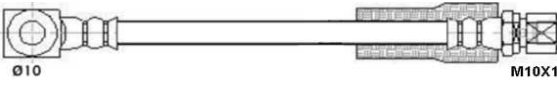

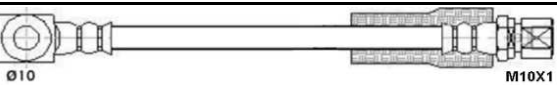
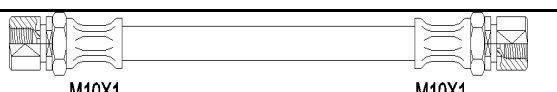
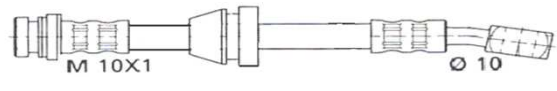
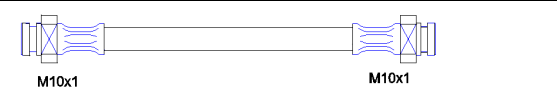
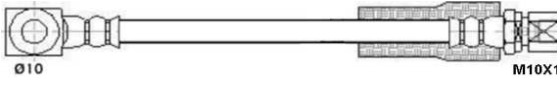
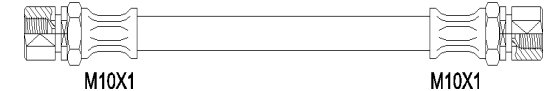
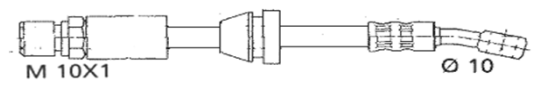

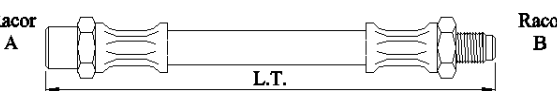
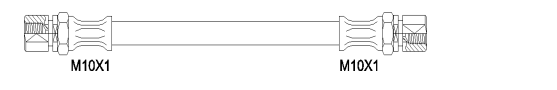
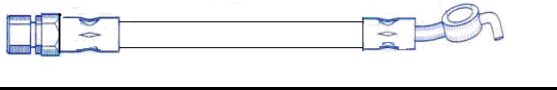
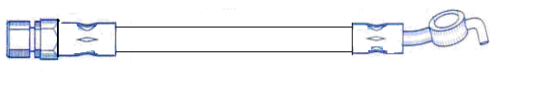
		BMW						
	Fecha Date	Eje Axle	Referencia Reference	Racor A Fitting	Racor B Fitting	LT		
SERIE 7 (E65, E66)								
Lado chasis	1993>96	T	61197	186	186	120		
Lado rueda		T	62074	186	187	225		
840 Ci, 850 Ci M73 lado chasis	1994>99	D	61197	186	186	120		
Lado rueda		D	64115	186	187	445		
Lado chasis		T	61197	186	186	120		
Lado rueda		T	62074	186	187	225		
850Ci M70, 850i	1989>94	D	64115	186	187	445		
		T	62074	186	187	225		
SERIE 8 (E31)								
840Ci	01/96>12/99	D	64109	186	187	470		
		T	62074	186	187	225		
840i	02/93>02/96	D	64109	186	187	470		
		T	62074	186	187	225		
850Ci	09/94>12/99	D	64109	186	187	470		
		T	62074	186	187	225		
850i, 850Ci	04/90>10/94	D	64109	186	187	470		
		T	62074	186	187	225		

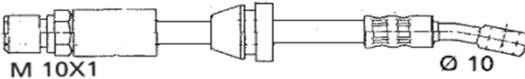
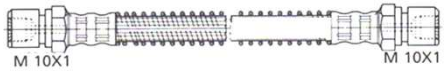

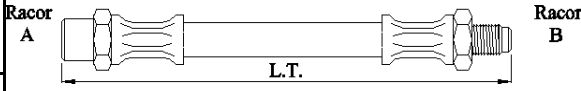
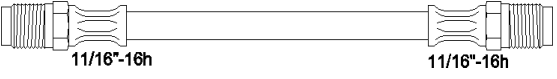
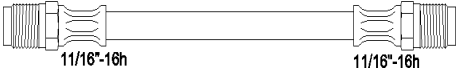
		BMW						
	Fecha Date	Eje Axle	Referencia Reference	Racor A Fitting	Racor B Fitting	LT		
X1 (E84)								
sDrive 18d, xDrive 18d	03/09>	T	62122			205		
		T	62123			265		
sDrive 18i, xDrive 25i	01/10>	T	62122			205		
		T	62123			265		
sDrive 20d, xDrive 23d, xDrive 28i	10/09>	T	62123			265		
xDrive 20d	10/09>	T	62122			205		
		T	62123			265		
X3 (E83)								
2.0 d	10/04>	D	63126			350		
		T	65055			540		
2.0 i	07/05>	D	63126			350		
		T	65055			540		
2.5 i, 3.0 i	01/04>	D	63126			350		
		T	65055			540		
3.0 d	01/04>	D	63126			350		
		T	65055			540		
xDrive 18d, xDrive 20d, xDrive 20i, xDrive 25i, xDrive 30d, xDrive 30i	09/08>	D	63126			350		

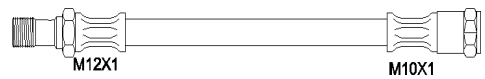
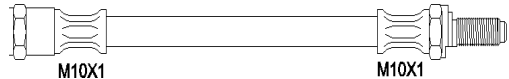
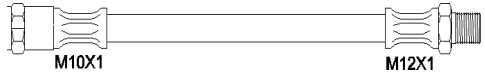
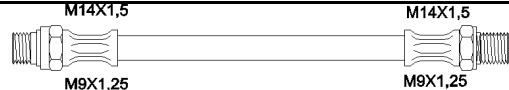

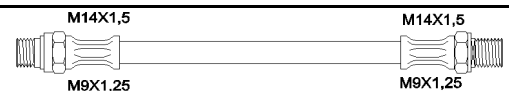

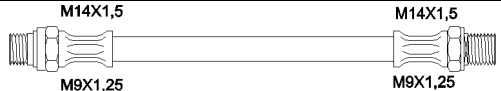
		BMW						
Fecha Date	Eje Axle	Referencia Reference	Racor A Fitting	Racor B Fitting	LT			
X3 (E83)								
xDrive 18d, xDrive 20d, xDrive 20i, xDrive 25i, xDrive 30d, xDrive 30i	09/08>	T	65055			540		
xDrive 35d	09/08>	T	65055			540		
X5 (E53)								
3.0 d	05/01>	D	65060			510		
		TI	65070			510		
		TD	65080			510		
3.0 i	05/00>	D	65060			510		
		TI	65070			510		
		TD	65080			510		
4.4 i	05/00>	D	65060			510		
		TI	65070			510		
		TD	65080			510		
4.6 is	02/02>	D	65060			510		
		TI	65070			510		
		TD	65080			510		
4.8 is	04/04>	D	65060			510		
		TI	65070			510		

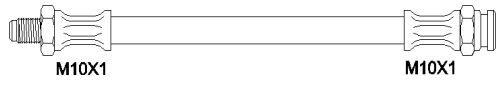
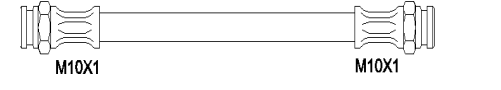
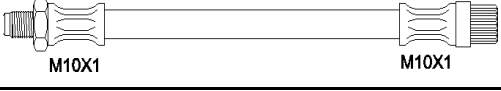
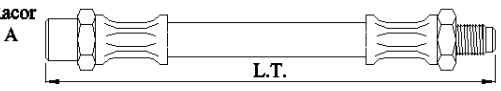
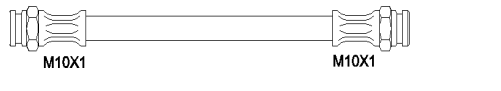
		BMW						
Fecha Date	Eje Axle	Referencia Reference	Racor A Fitting	Racor B Fitting	LT			
X5 (E53)								
4.8 is	04/04>	TD	65080			510		
SERIE Z 1								
Roadster	1988>	D	63213	186	187	330		
SERIE Z 3								
Roadster 1.8, 1.9 M43, 1.9 M44, 2.0, 2.2i, 2.8, 3.0i	1994>	D	64115	186	187	445		
Roadster M3.2 S50, M3.2 S54	1996	D	64109	186	187	470		
Todos modelos		T	62074	186	187	225		
Z4 (E85)								
Todos modelos	1998>	D	64013	244	253	450		
SERIE Z 8								
Roadster		T	63344	186	187	300		
		CHEVROLET(DAEWOO)						
Fecha Date	Eje Axle	Referencia Reference	Racor A Fitting	Racor B Fitting	LT			
ARANOS								
Todos	1995>	D	63247		211	340		
		T	62037	211	211	235		
ESPERO								

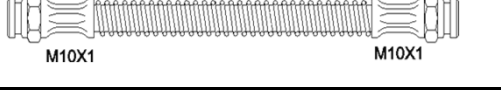
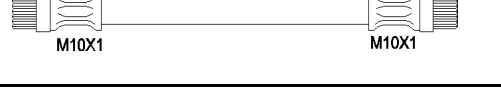
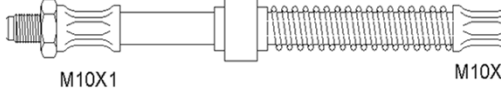
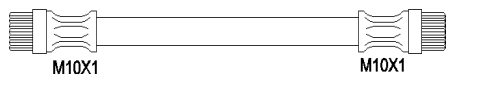
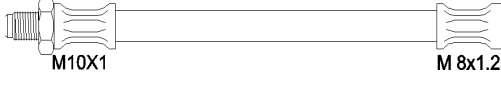
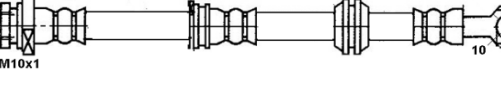
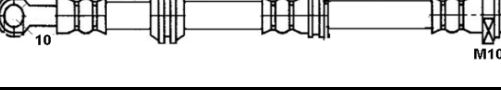
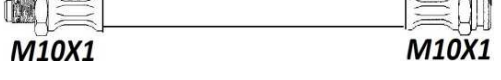

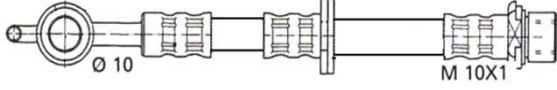
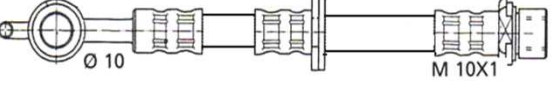
1.5 16V, 1.8, 2.0	1995>	D	63247		211	340	
		T	62037	211	211	235	
LANOS							
1.5, 1.6 16V, 1.8, 2.0	1997>	D	63247		211	340	
	05/97>	T	62037	211	211	235	
MATIZ							
0,8	1998>	D	64214			445	
		T	62216			242	
NEXIA							
1.5l, 1.5 16V, 1.8,	1995>	D	63247		211	340	
		T	62037	211	211	235	
NUBIRA							
1.6 16V, 2.0 16V	1997>	D	64245	211		414	
	1997>	TD	62028	211	211	248	
CHEVROLET(DAEWOO)							
	Fecha Date	Eje Axle	Referencia Reference	Racor A Fitting	Racor B Fitting	LT	
NUBIRA							
1.6 16V, 2.0 16V	1997>	TI	62028	211	211	248	
2.0 16V	1997>	TD	63424	211		340	
		TI	63425	211		340	

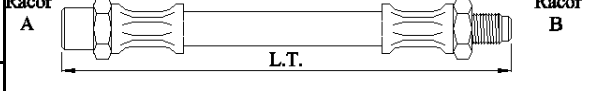
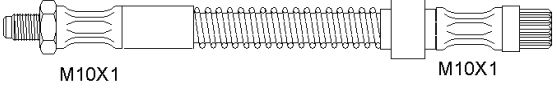
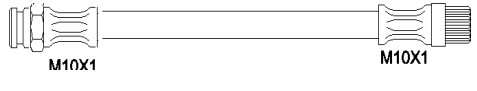
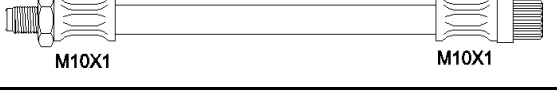
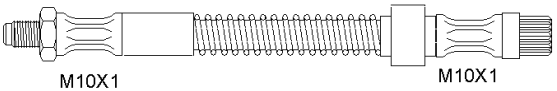
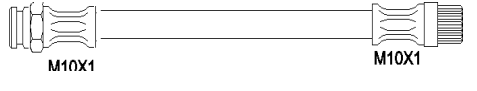
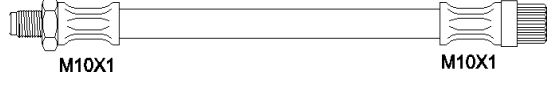
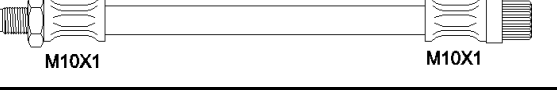
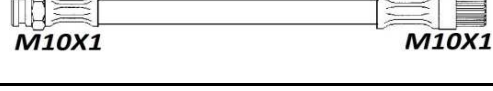
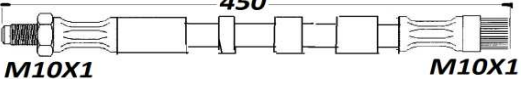

REZZO								
Todos modelos	2001>04	D	64245	211		414		
		TI	62032	211	211	242		
		TD	63427	211	211	315		
		CITROËN						
		Fecha Date	Eje Axle	Referencia Reference	Racor A Fitting	Racor B Fitting	LT	
7, 11, 11L, 11D, 15CV								
Todos modelos	>1957	D	63020	003	003	380		
		T	61010	003	003	145		
2 CV, DYANE, Y DERIVADOS								
Break Dinam		D	63271	109	112	335		
		T	63280	109	110	304		
2 CV y Derivados	>1966	D	62520	013	014	285		
		T	63650	014	015	315		
2 CV y Derivados	1966>	D	62158	014	112	280		
		T	63280	109	110	304		
2CV Furgonetas AK, AZU, AKS		D	63113	110	112	302		
		T	63280	109	110	304		
DYANE 6, MEHARI		D	62151	110	112	222		
		T	63280	109	110	304		

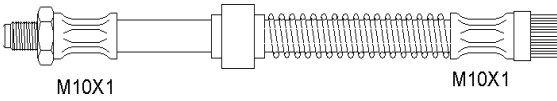
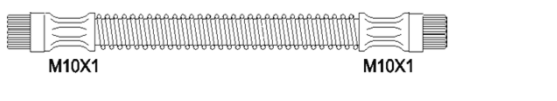
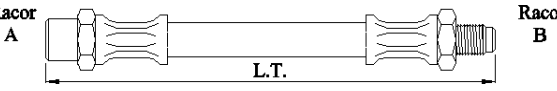
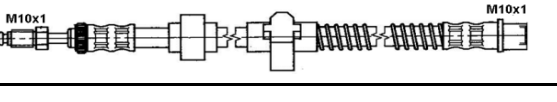
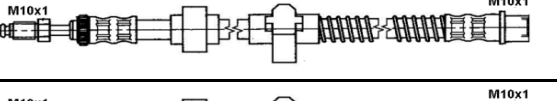
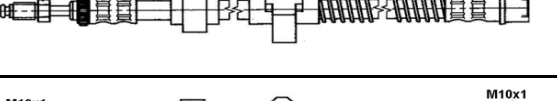
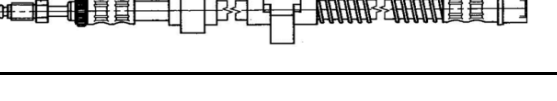
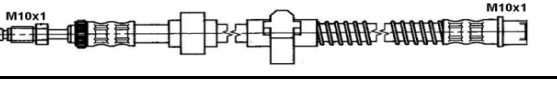
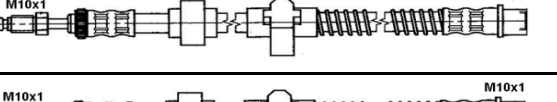
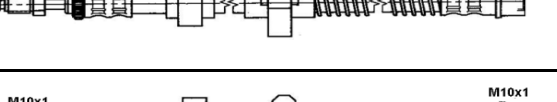
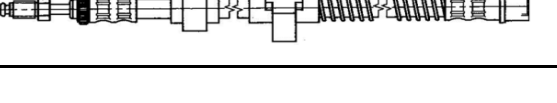
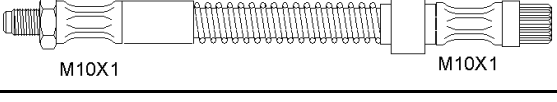
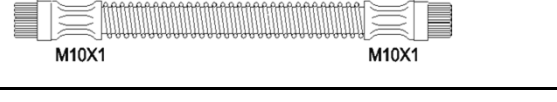

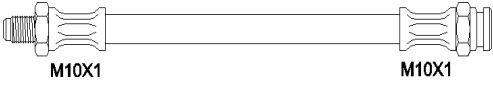
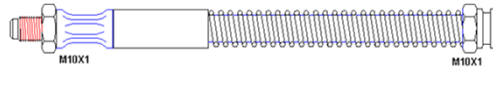

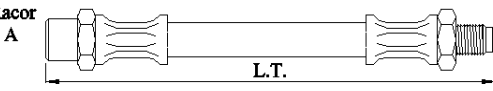
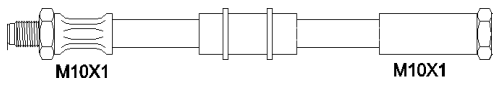
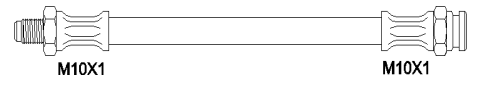
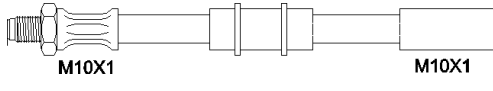
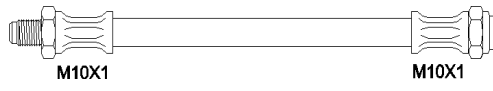
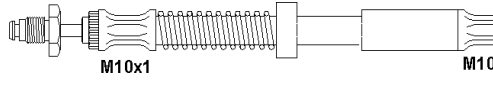
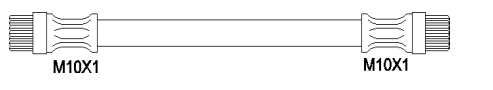
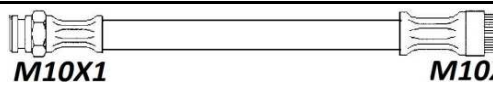
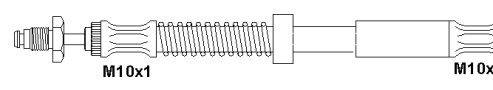
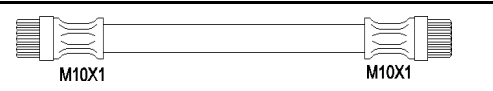
AX								
Todos modelos (-servo)	86>91	D	63084	187	191	350		
		T	62054	191	191	216		
Todos modelos (+servo)	86>91	D	63195	187	227	350		
		CITROËN						
		Fecha Date	Eje Axle	Referencia Reference	Racor A Fitting	Racor B Fitting	LT	
AX								
Todos modelos (+servo)	86>91	T	62054	191	191	216		
AX 1.0, 1.1	91>96	D	63214	187	227	315		
	91>94	T	62049	191	191	207		
	94>	T	62083	227	227	220		
BERLINGO								
Todos modelos	96>	D	64112	187	227	460		
		T	62088	227	227	277		
BX								
BX Líquido mineral (Verde)		D	64080	187	236	465		
C- CROSSER								
Todos modelos	02/2007>	DI	66004			630		
Todos modelos	02/2007>	DD	66003			630		
Todos modelos		T	63272	187	191	310		

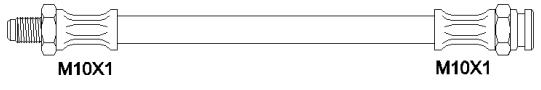
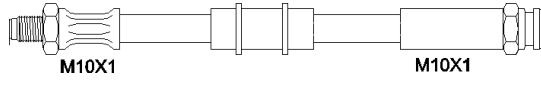
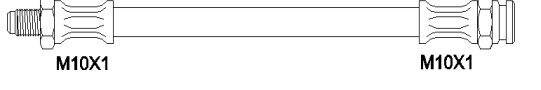
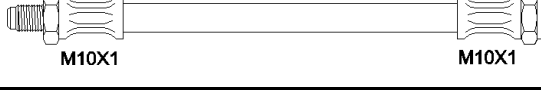
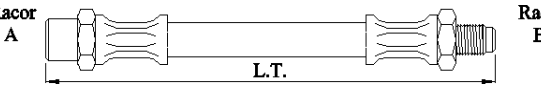
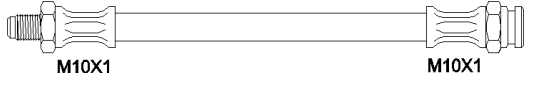
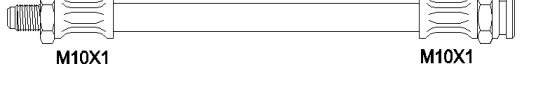
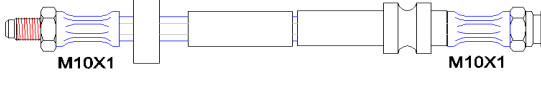
C 1							
Todos modelos	2005>	DI	65136			510	
		DD	65135			510	
		T	62355	283	283	255	
CITROËN							
Fecha Date	Eje Axle	Referencia Reference	Racor A Fitting	Racor B Fitting	LT		
C 2							
Todos modelos	09/2003>	D	64049	187	227	485	
	2003>05	T	62215	191	227	205	
	2005>	T	64242	187	227	445	
C 3, C3 PLURIEL							
Todos modelos	09/003>	D	64049	187	227	485	
	2003>05	T	62215	191	227	205	
	2005>	T	64242	187	227	445	
C4							
Todos modelos	12/2005>	D	64242	187	227	445	
Todos modelos	12/2005>	T	62118	191	227	210	
C4 Picasso							
Todos modelos	10/2006>	D	64173	187	227	450	
Todos modelos	10/2006>	T	62119	191	227	235	

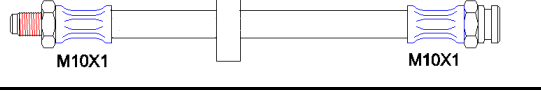
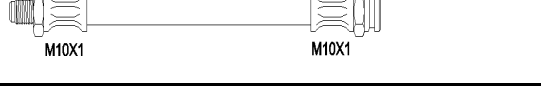
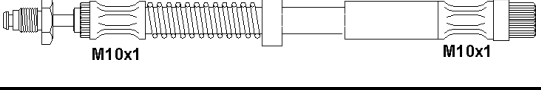
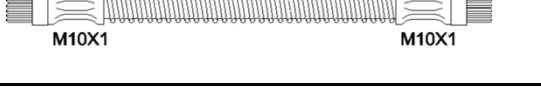
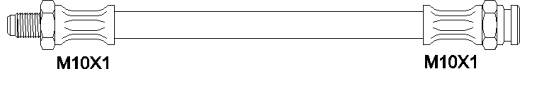
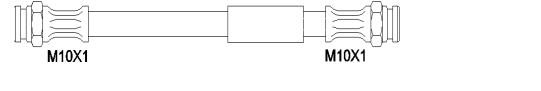

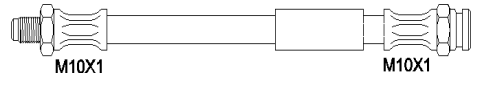
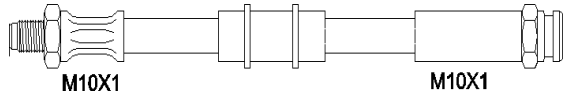
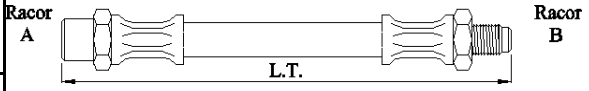
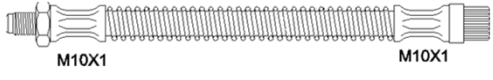

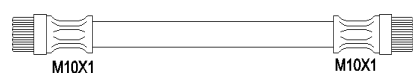
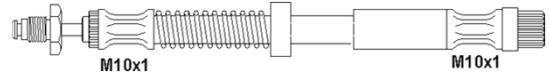
C 5								
Todos modelos	2001>	D	65093	187	227	580		
		T	62105	227	227	265		
CITROËN								
Fecha Date	Eje Axle	Referencia Reference	Racor A Fitting	Racor B Fitting	LT			
C5 III								
Todos modelos	2008>	TI	66001			685		
Todos modelos	2008>	TD	66002			685		
Todos modelos	2009>	TI	66001			685		
Todos modelos	2009>	TD	66002			685		
C6								
Todos modelos	05/2004>02/11	TI	66001			685		
Todos modelos	05/2004>02/11	TD	66002			685		
Todos modelos	02/2011>	TI	66001			685		
Todos modelos	02/2011>	TD	66002			685		
C 8								
Todos modelos	2002>	D	64049	187	227	485		
		T	62187	227	227	272		
C15								

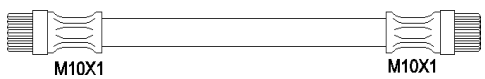
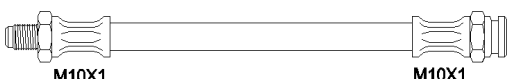
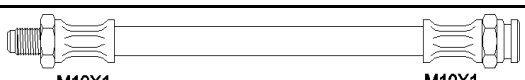
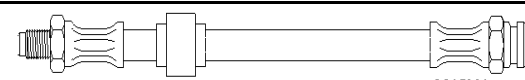
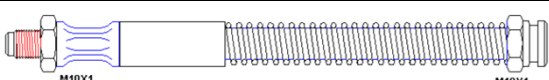

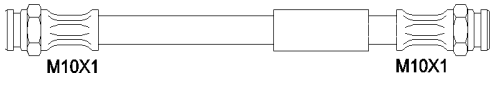
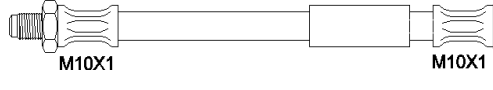
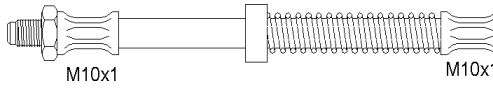
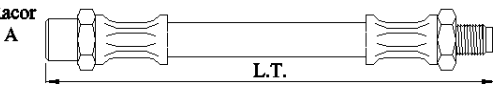
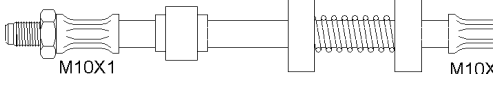
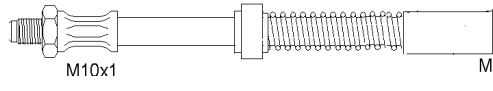
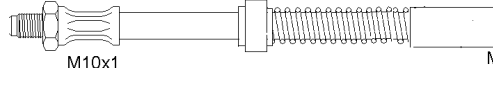
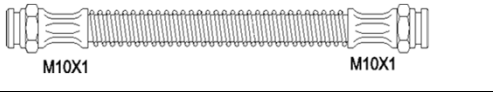
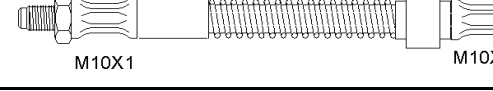
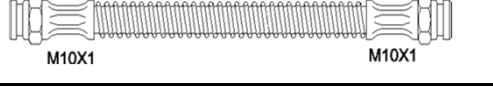
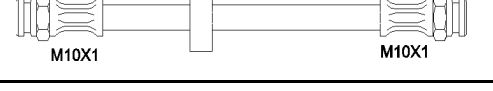
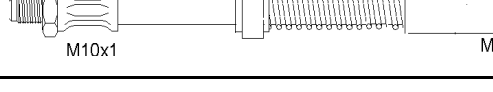
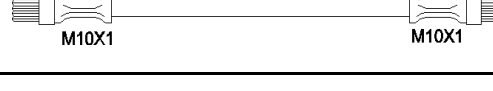
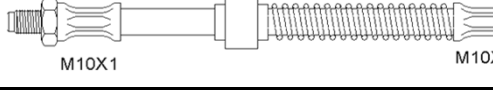
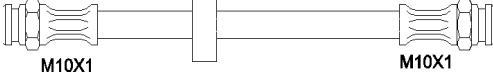

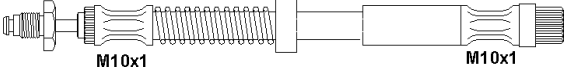
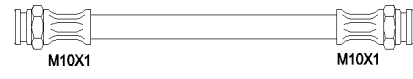
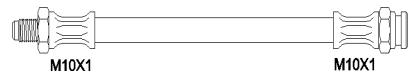
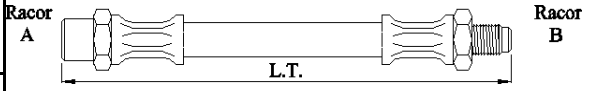

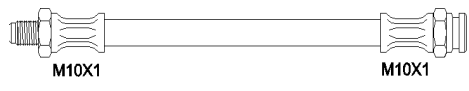
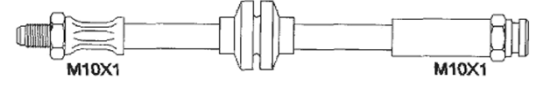
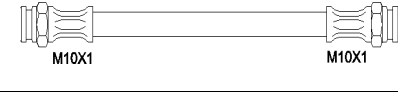
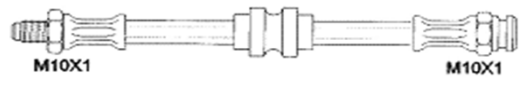
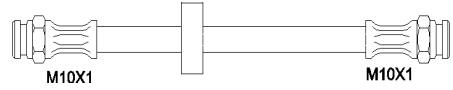
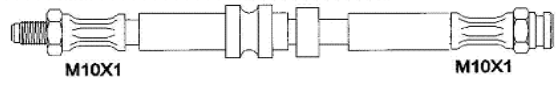
Todos modelos	>87	D	63068	187	191	375	
Todos modelos	87>	D	63073	187	191	355	
Todos modelos		T	62049	191	191	207	
CITROËN							
							
	Fecha Date	Eje Axle	Referencia Reference	Racor A Fitting	Racor B Fitting	LT	
C25							
Todos modelos	1981>86	D	63270	187	191	385	
		T	63162	187	191	289	
Todos modelos	1987>	D	64081	187	191	460	
		T	63272	187	191	310	
DISPATCH							
Todos modelos	1995>	D	65075	242	227	540	
		T	62088	227	227	277	
DS4							
Todos modelos	2010>	T	62118	191	227	210	
EVASION							
Todos modelos	1994>	D	65075	242	227	540	
		T	62059	227	227	275	
JUMPER I							

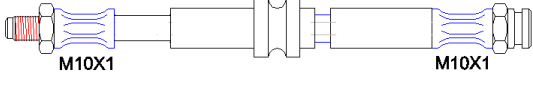
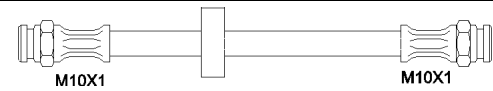
Todos modelos (-ABS)	02/1994>	DS	63236	187	191	485	
Todos modelos (+ABS)		DI	63370	187	191	480	
		T	63318	187	191	345	
Todos modelos (+ABS)	02/1994>	D	63236	187	191	485	
CITROËN							
	Fecha Date	Eje Axle	Referencia Reference	Racor A Fitting	Racor B Fitting	LT	
JUMPER I							
Todos modelos (+ABS)	02/1994>	TI	63084	187	191	350	
		TD	63199	187	191	360	
JUMPER II							
Todos modelos	04/2002>	D	64213	187	191	493	
Freno de tambor		T	63371	187	191	383	
Freno disco lado chasis		T	63371	187	191	383	
Freno de disco lado rueda		T	61202	187	191	183	
JUMPI							
Todos modelos	1995>	D	65075	242	227	540	
		T	62187	227	227	272	
LNA							
Todos modelos	1976>	D	63068	187	191	375	
		TD	62061	191	191	272	

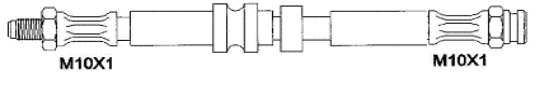
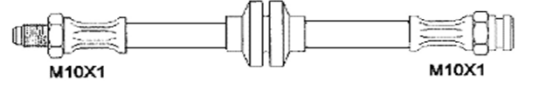
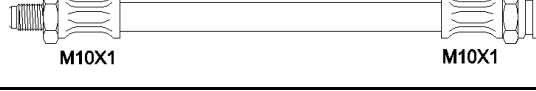
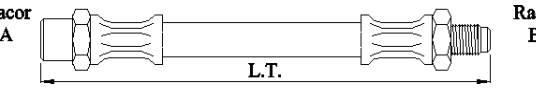

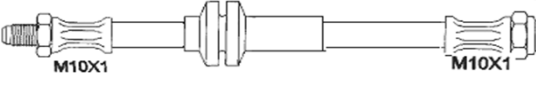
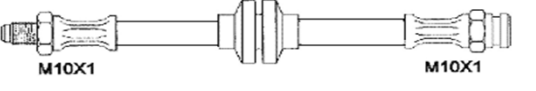
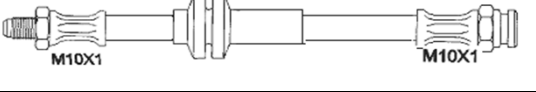

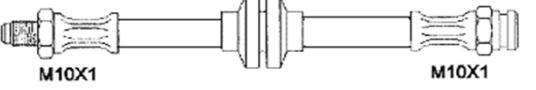
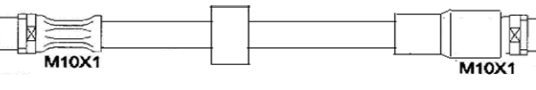
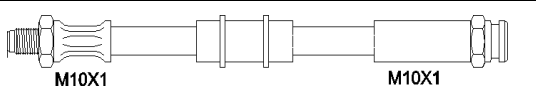

		TI	62062	187	191	294	
RELAY	Fecha	Eje	Ref.	A	B	LT	
	1986>	D	64081	187	191	457	
CITROËN							
							
	Fecha Date	Eje Axle	Referencia Reference	Racor A Fitting	Racor B Fitting	LT	
SAXO							
Todos modelos (+ABS)	1996>99	D	63372	187	227	325	
Todos modelos (-ABS)	1996>99	D	63268	187	227	354	
Todos modelos	1999>	D	63214	187	227	315	
Todos modelos	1996>	T	62083	227	227	220	
SYNERGIE							
Todos modelos	1995>	D	65075	242	227	540	
Trasero		T	63372	187	227	325	
Trasero exterior		T	62059	227	227	272	
VISA							
Todos modelos (-1.7D, 1.6 GTI)	1978>86	D	63084	187	191	347	
Todos modelos (-1.7D, 1.6 GTI)	1978>86	D	63068	187	191	375	
Todos modelos 1.6 GTI		D	64059	187	191	440	
Todos modelos 1.7D		D	63073	187	191	355	

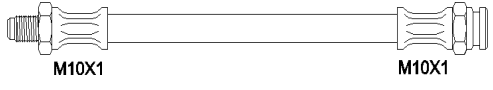
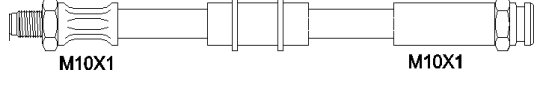
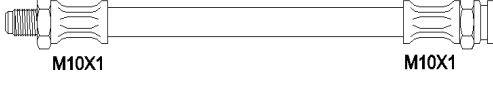
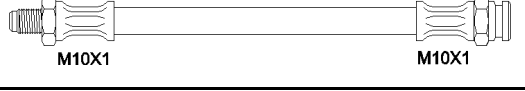
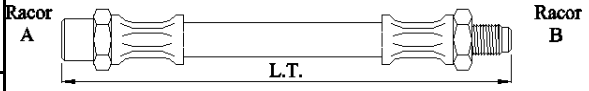
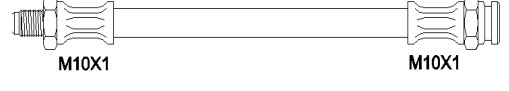
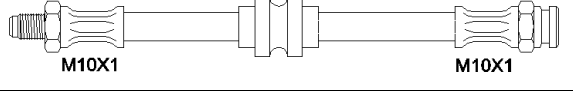
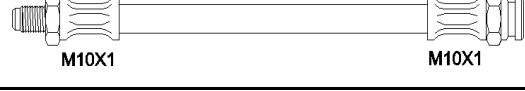
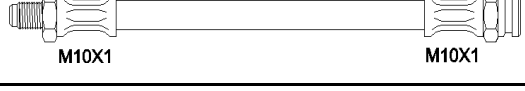
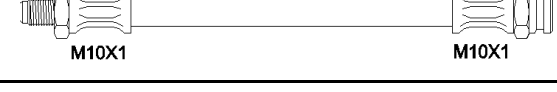
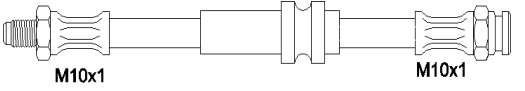
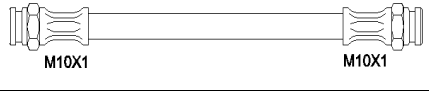
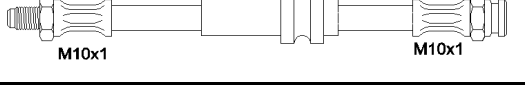
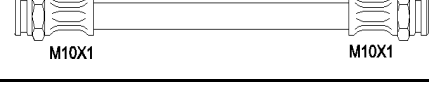
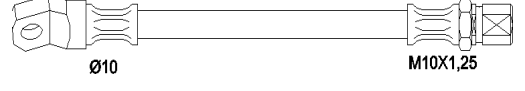

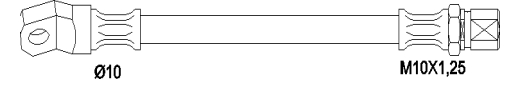
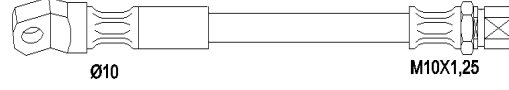
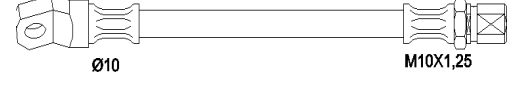
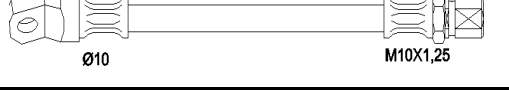
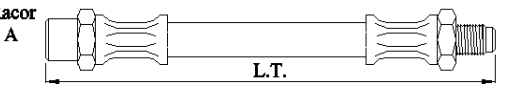
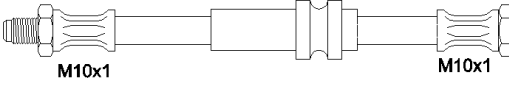
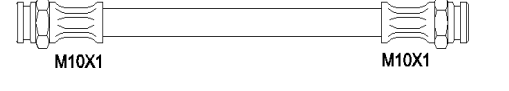
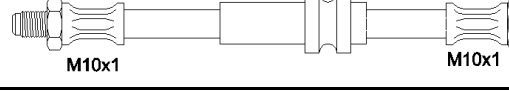
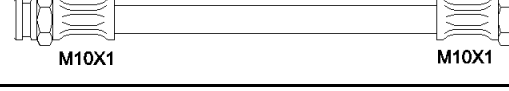
Todos modelos		TI	62061	191	191	272	
		TD	63078	187	191	380	
XANTIA							
Todos modelos liq. LHM	93>97	D	63231	187	227	390	
CITROËN							
Fecha Date	Eje Axle	Referencia Reference	Racor A Fitting				
XM							
Todos modelos liq. LHM	97>	D	65063	187	227	575	
XSARA / PICASO							
Todos modelos (-ABS) sin compensador, pinza Bosch	1997>	D	64045	187	227	463	
Todos modelos (-ABS) sin compensador, pinza Teves		D	64049	187	227	490	
		T	62049	187	227	207	
Todos modelos	1997>	D	64049	187	227	490	
		TI	62049	191	191	207	
		TD	63092	191	191	263	
Picaso	1997>	D	64045	187	227	463	
		T	62088	227	227	277	
ZX							
Todos modelos	1991>96	D	64112	187	227	460	
		TI	63092	191	191	263	

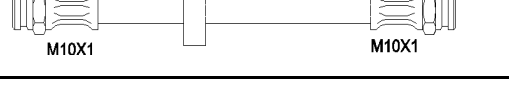
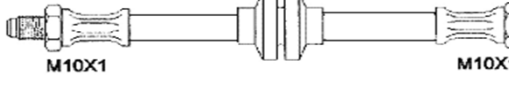
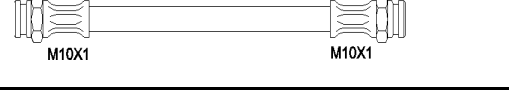

		TD	62049	191	191	207	
<i>Todos modelos</i>	1996>	D	65077	242	227	510	
<i>Lado chasis</i>		T	62054	191	191	213	
<i>Lado rueda</i>		T	61196	187	191	176	
FIAT							
	Fecha Date	Eje Axle	Referencia Reference	Racor A Fitting	Racor B Fitting	LT	
ARGENTA							
<i>1.6, 2.0D</i>	1981>86	D	63199	187	191	360	
		T	62046	187	191	287	
BARCHETA							
	1995>	D	63238	187	191	419	
		T	61201	191	191	166	
BRAVO / BRAVA							
<i>1.4, 1.6, 1.8, 1.9D</i>	1995>	D	63234	187	191	409	
		T	62077	191	191	243	
<i>2.0 ABS Freno de disco</i>	1995>	D	64145	187	191	440	
		T	61196	187	191	187	
CINQUECENTO							
<i>Todos modelos 700-900</i>	1992>	D	64169	187	191	468	
		T	64176	191	191	293	

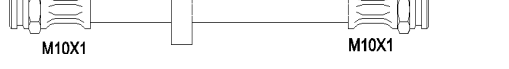
COUPE								
Todos modelos	1993>96	D	64145	187	191	440		
Todos modelos	1996>	D	64092	187	191	410		
Todos modelos Lado rueda		T	61196	187	191	187		
		FIAT						
	Fecha Date	Eje Axle	Referencia Reference	Racor A Fitting	Racor B Fitting	LT		
COUPE								
Todos modelos Lado chasis		T	62077	191	191	243		
CROMA								
Todos modelos (-ABS)	1985>91	D	65052	187	191	587		
		T	64092	187	191	410		
Todos modelos (+ABS)	1985>91	D	64093	187	191	410		
		T	64092	187	191	410		
IE Turbo	1992>	D	65052	187	191	587		
		T	65074	187	191	561		
DOBLÓ								
Todos modelos	2001>	D	65094	187	191	500		
		T	64215	253	253	458		
DUCATO								
Todos modelos (-4X4)	1981>83	D	63270	187	191	385		

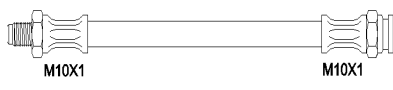
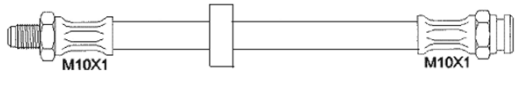
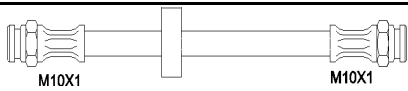
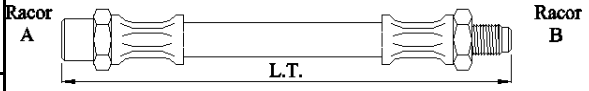
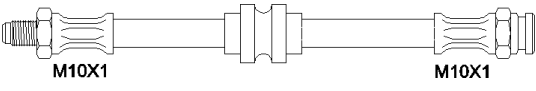
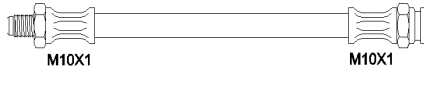
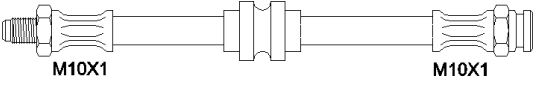
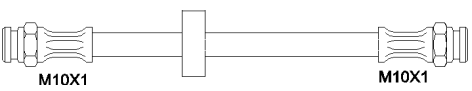

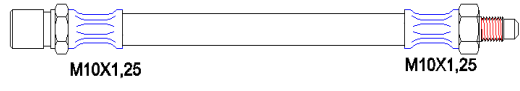
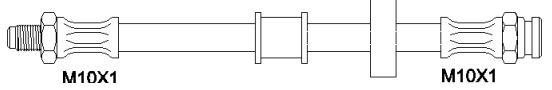
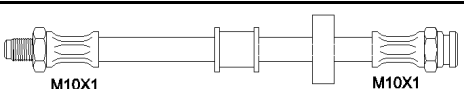
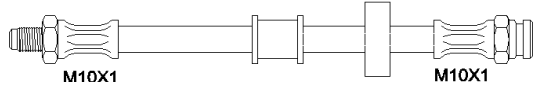
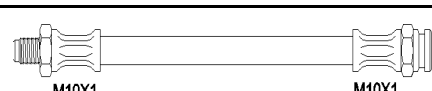
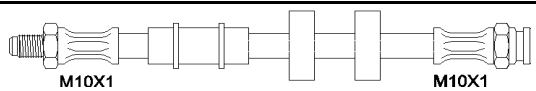
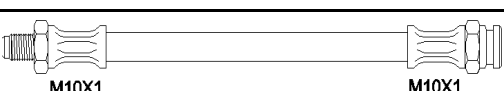
		T	63162	187	191	289	
Todos modelos (-4X4)	1983>94	D	64081	187	191	460	
		T	63162	187	191	289	
4X4		D	63272	187	191	310	
FIAT							
	Fecha Date	Eje Axle	Referencia Reference	Racor A Fitting	Racor B Fitting	LT	
DUCATO							
4X4		T	62046	187	191	287	
Todos modelos	1994>	D	64095	187	191	490	
Todos modelos (-ABS)		T	63084	187	191	350	
Todos modelos (+ABS)		TI	63084	187	191	350	
		TD	63199	187	191	360	
DUNA							
Todos modelos	1986>90	D	63265	187	191	382	
		T	62184	191	191	278	
ELVA							
	1991>96	D	63265	187	191	382	
		T	62184	191	191	278	
FIORINO							
Todos modelos	>1983	D	62163	051	132	285	

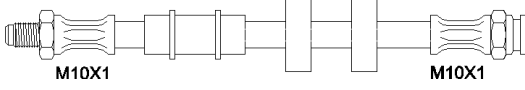
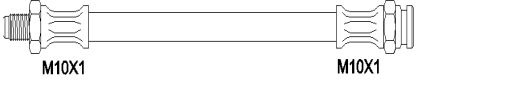
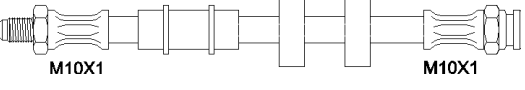
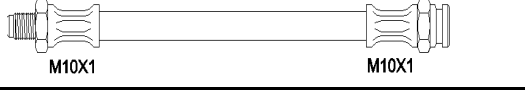
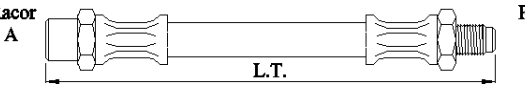
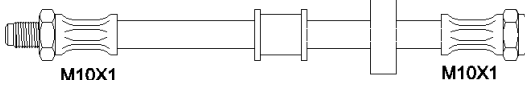
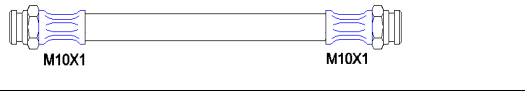

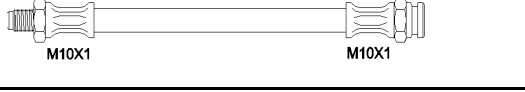
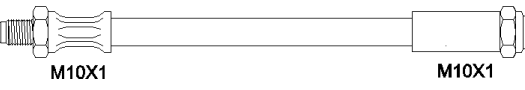
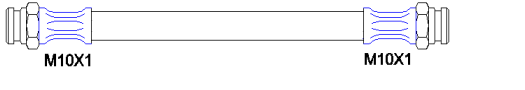

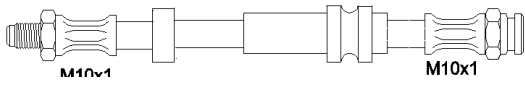
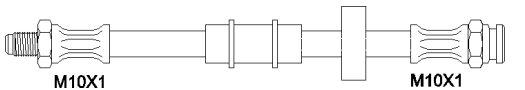
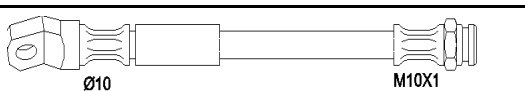
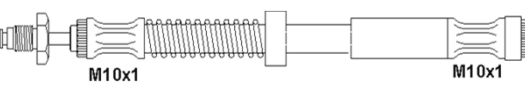
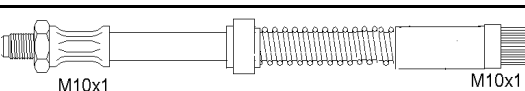
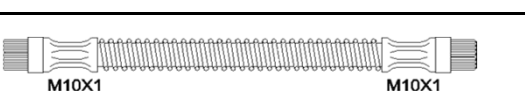
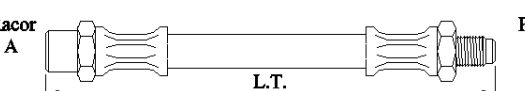
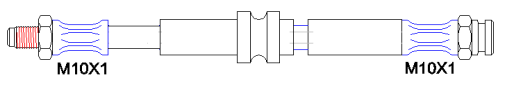
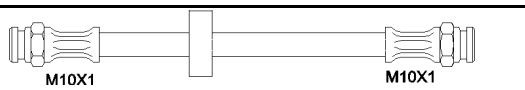
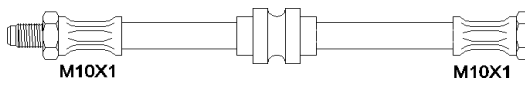
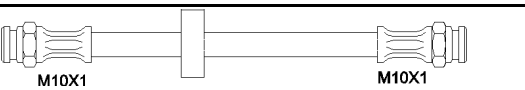
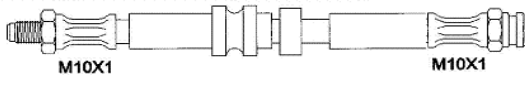
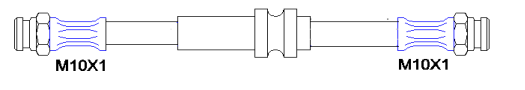
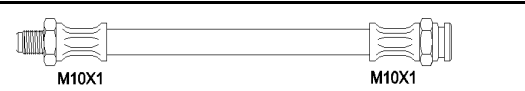
		<i>T</i>	62186	051	132	258	
<i>Todos modelos</i>	1983>88	<i>DD</i>	63266	051	132	310	
		<i>DI</i>	63267	051	132	300	
		<i>T</i>	62186	051	132	258	
FIAT							
	<i>Fecha Date</i>	<i>Eje Axle</i>	<i>Referencia Reference</i>	<i>Racor A Fitting</i>	<i>Racor B Fitting</i>	<i>LT</i>	
FIORINO							
<i>Todos modelos</i>	1989>93	<i>D</i>	63265	187	191	382	
		<i>T</i>	62184	191	191	278	
<i>Todos modelos</i>	1993>01	<i>D</i>	63265	187	191	382	
		<i>T</i>	63373	191	191	388	
<i>(-ABS</i>	1996>	<i>D</i>	64145	187	191	440	
		<i>T</i>	62077	191	191	243	
IDEA							
<i>Todos modelos</i>	12/2003>	<i>D</i>	65103	187	191	520	
		<i>T</i>	61182	191	191	195	
MAREA							
<i>Todos modelos BZ (-2.0 20V), 1.9TD, 1.9JTD</i>	07/1996>	<i>D</i>	64145	187	191	440	
		<i>D</i>	64092	187	191	410	
<i>2.0 20V, 2.4 TD, 2.4JTD</i>		<i>D</i>	64092	187	191	410	
<i>Todos modelos</i>		<i>T</i>	63092	191	191	243	

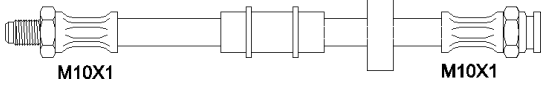
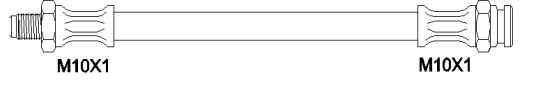
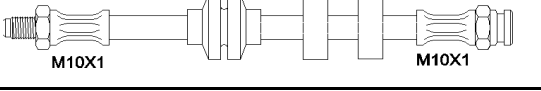
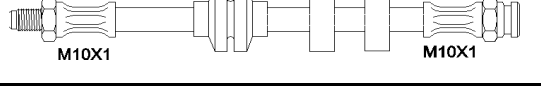
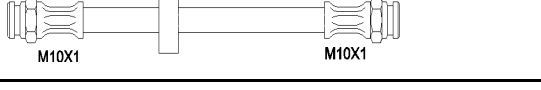
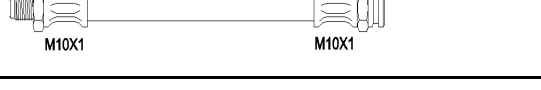
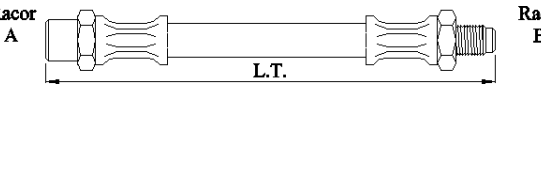
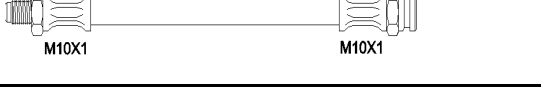
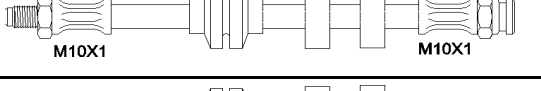
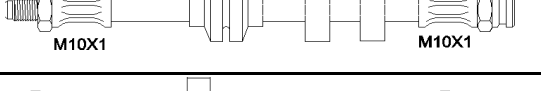
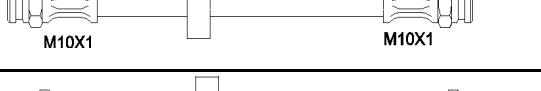
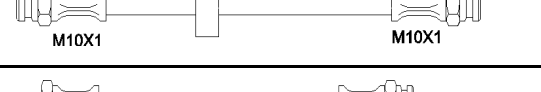
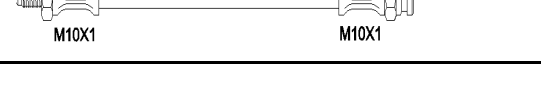
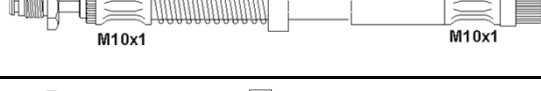



2.0 20V, 2.4 TD, 2.4JTD Lado pinza		T	61196	187	191	185	
MULTIPLA							
Todos modelos	1999>	D	64098	187	191	465	
		T	62077	191	191	243	
FIAT							
	Fecha Date	Eje Axle	Referencia Reference	Racor A Fitting	Racor B Fitting	LT	
PALIO							
Todos modelos (Excepto Weekend)	1997>	D	64095	187	191	490	
		T	62106	187	191	233	
Todos modelos Weekend		D	64095	187	191	490	
		T	62077	191	191	243	
PANDA							
30-45	1981>82	D	63266	051	132	310	
		T	63042	028	179	350	
30-45	1982>85	D	64032	187	191	464	
		T	62046	187	191	287	
750,1000, 1100	1986>91	D	64032	187	191	464	
		T	62071	187	191	210	
1000 4X4	1986>91	D	64089	187	191	410	
		T	63089	187	191	337	

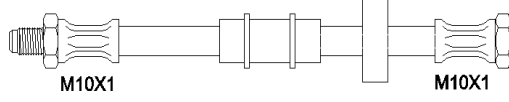
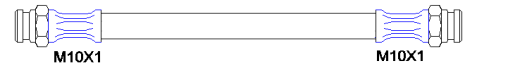
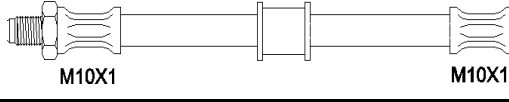
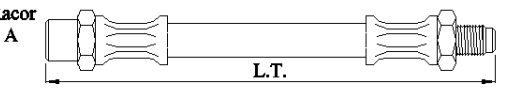
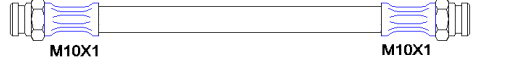
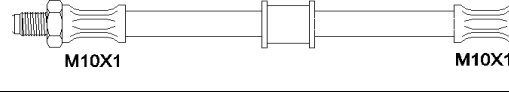

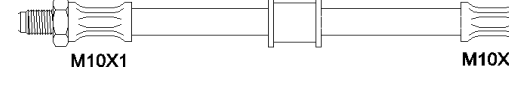
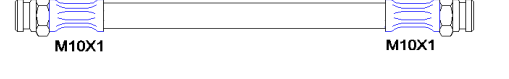
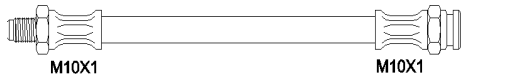
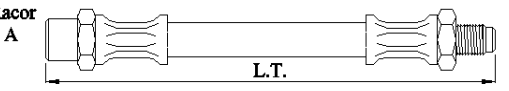
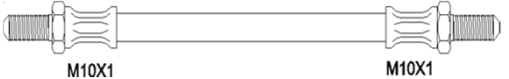

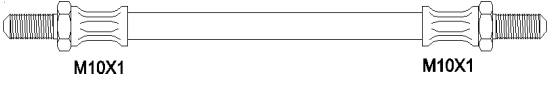
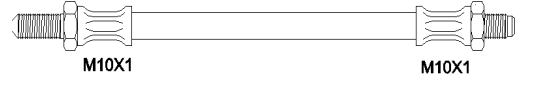
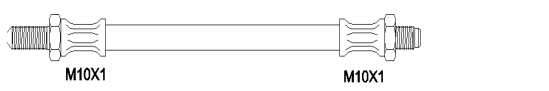

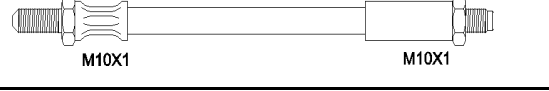
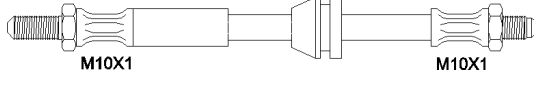
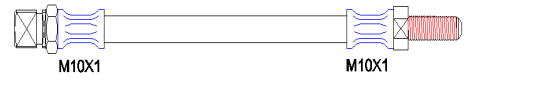

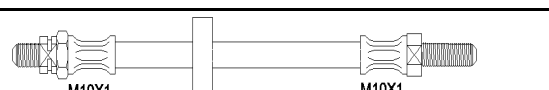
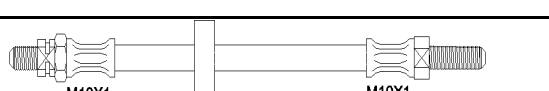
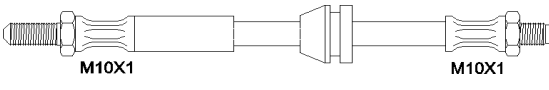
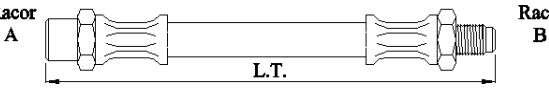
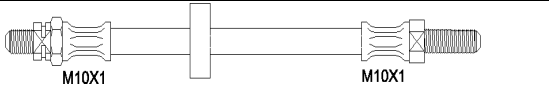
1.3D	1986>91	D	64089	187	191	410	
		T	62071	187	191	210	
Todos	1991>	D	64089	187	191	410	
		T	62071	187	191	210	
FIAT							
	Fecha Date	Eje Axle	Referencia Reference	Racor A Fitting	Racor B Fitting	LT	
PANDA							
Panda II	09/2003>	D	64032	187	191	464	
		T	61182	191	191	195	
PUNTO							
Todos modelos	1993>99	D	63149	187	191	400	
			63324				
	1993-2000	DI	63345				
	1993-2000	DD	63346				
Todos modelos Lado chasis		T	62056	191	191	216	
Todos modelos Lado rueda		T	61196	187	191	185	
PUNTO II							
Todos modelos	09/1999>	D	65095	187	191	478	
		T	61182	191	191	195	
REGATA							

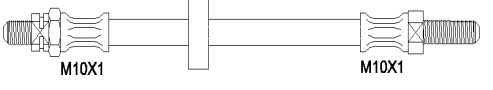
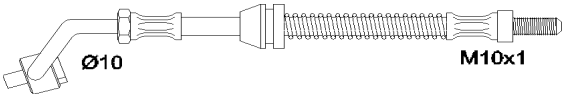
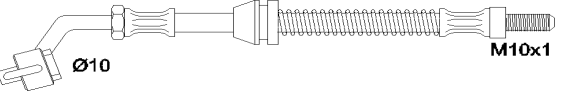
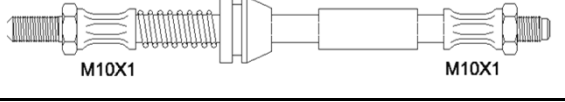
Todos modelos	1984>85	D	64183	187	191	437	
	1985>	D	64068	187	191	415	
		T	62055	051	191	296	
SCUDO							
Según modelo	1995>03	D	65075	242	227	540	
Según modelo		D	64049	187	227	485	
Todos modelos		T	62187	227	227	272	
FIAT							
	<i>Fecha Date</i>	<i>Eje Axle</i>	<i>Referencia Reference</i>	<i>Racor A Fitting</i>	<i>Racor B Fitting</i>	<i>LT</i>	
SEICENTO							
Todos modelos	1998>	D	64169	187	191	468	
		T	64176	191	191	293	
SIENA							
Todos modelos	1997>	D	64095	187	191	490	
		T	63092	191	191	265	
STILO							
Todos modelos		D	64145	187	191	440	
Todos modelos Lado chasis		T	63374	191	191	305	
Todos modelos Lado rueda	01>	T	62071	187	191	210	
TALENTO							

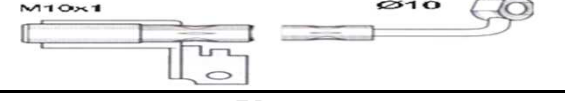
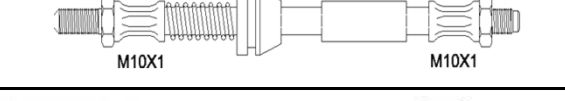
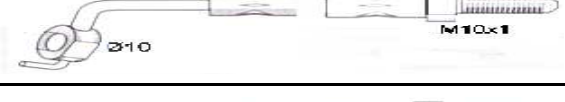

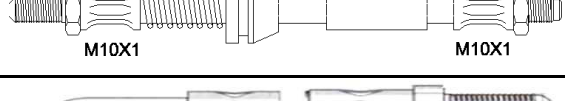
Todos modelos	1989>	D	64067	187	191	464	
		T	63089	187	191	337	
TEMPRA							
(-ABS)	1989>	D	63091	187	191	390	
(+ABS)		D	64091	187	191	412	
(-ABS)		T	62077	191	191	243	
(+ABS) Todos modelos exp 2.0		T	61196	187	191	187	
FIAT							
	<i>Fecha Date</i>	<i>Eje Axle</i>	<i>Referencia Reference</i>	<i>Racor A Fitting</i>	<i>Racor B Fitting</i>	<i>LT</i>	
TEMPRA							
(+ABS) 2.0		T	62071	187	191	210	
TIPO							
1.1, 1.4, 1.6, 1.7D, 1.9D 1.6S, 1.8, 1.8 16V, 2.0, 1.9TD 1.1, 1.4, 1.6, 1.8, 2.0, 1.7D, 1.9D, 1.9TD 1.8 16V, 2.0 16V, Lado rueda (pinza)	1988	D	63091	187	191	390	
		D	64091	187	191	412	
		T	63092	191	191	265	
		T	62077	191	191	243	
		T	61196	187	191	187	
ULYSSE							
Todos modelos	1994>	D	65075	242	227	540	
	09/2002>	D	64049	187	227	485	

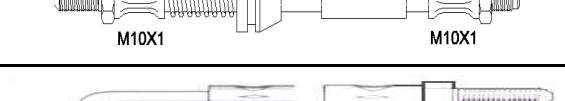

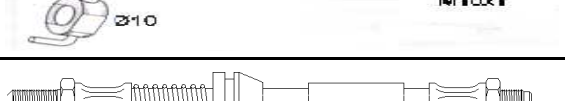
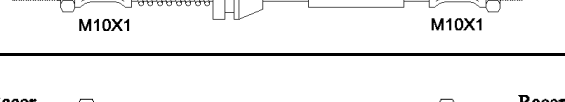
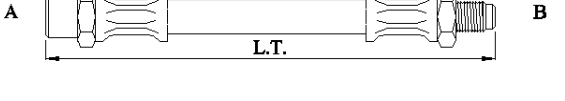
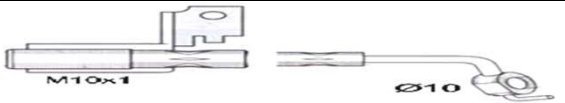

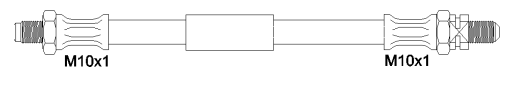
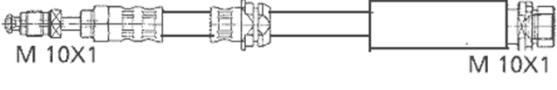
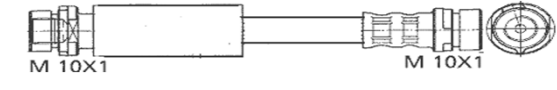
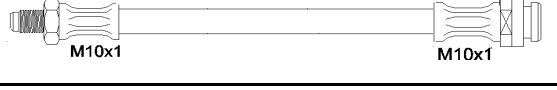
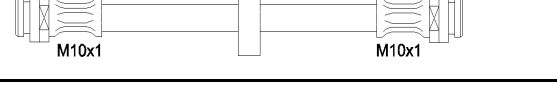
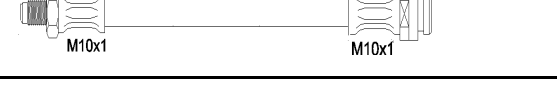
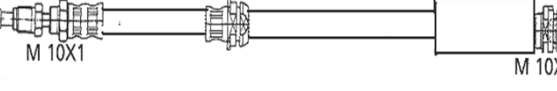
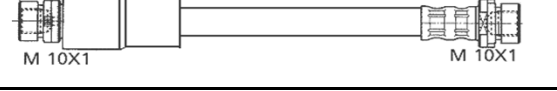
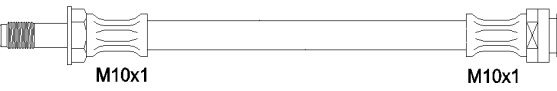
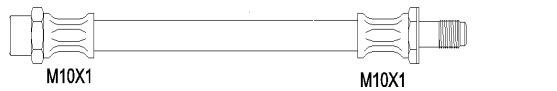
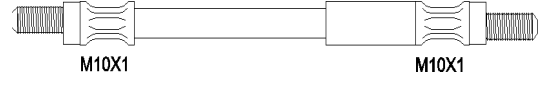
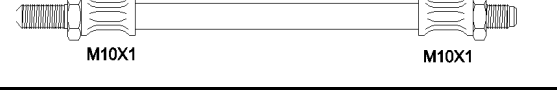
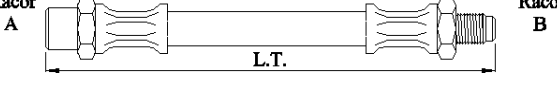
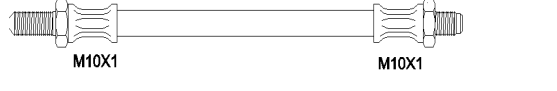

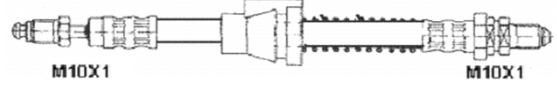
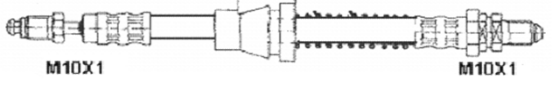
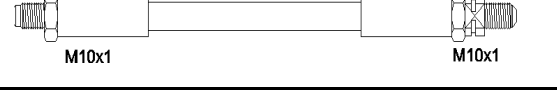
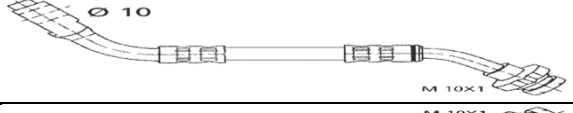
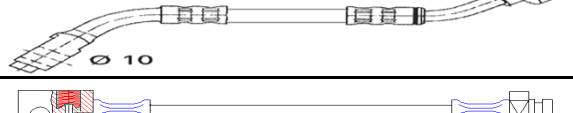
Freno tambor		T	62187	227	227	272	
Lado chasis		T	62187	227	227	272	
Lado rueda		T	63233	187	227	330	
UNO							
Todos modelos	>1986	D	63149	187	191	407	
		T	62056	191	191	216	
Todos modelos	1986>	D	64113	187	191	460	
FIAT							
							
	Fecha Date	Eje Axle	Referencia Reference	Racor A Fitting	Racor B Fitting	LT	
UNO							
		T	62056	191	191	216	
Turbo (-ABS)	1989>	D	64113	187	191	460	
		T	61035	187	191	160	
Turbo (+ABS)	1989>	D	64113	187	191	460	
		T	62056	191	191	216	
		T	61035	187	191	160	
FORD							
							
	Fecha Date	Eje Axle	Referencia Reference	Racor A Fitting	Racor B Fitting	LT	
CAPRI							
Todos modelos	1974>78	D	63048	185	185	330	

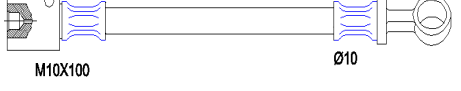
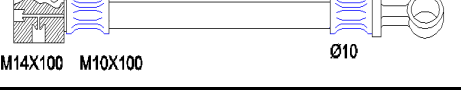
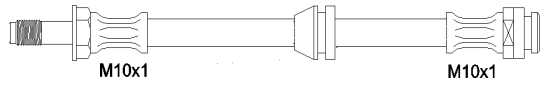
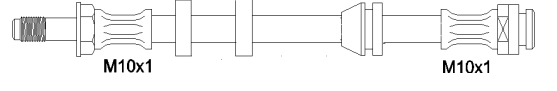
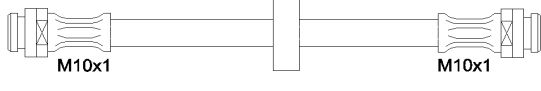
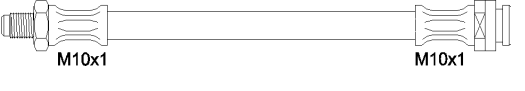
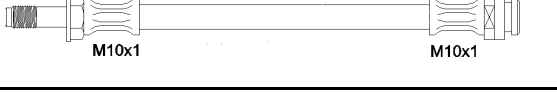
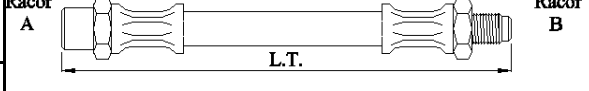
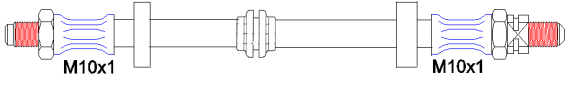

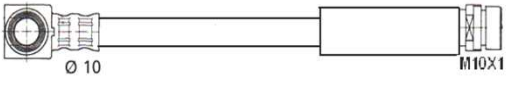
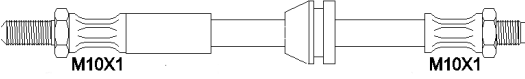
		<i>T</i>	64004	117	117	500	
CONSUL							
<i>Todos modelos</i>	1972>75	<i>D</i>	65047	185	185	520	
		<i>T</i>	63201	185	187	355	
		<i>T</i>	63021	185	187	244	
CORTINA-TAUNUS							
<i>Todos modelos</i>	1973>	<i>D</i>	65025	203	203	520	
		<i>T</i>	63048	185	185	330	
ESCORT / ORION							
SERIE II <i>Todos modelos</i>	1980>83	<i>D</i>	63044	185	187	313	
	1984>86	<i>D</i>	64057	185	187	410	
	1980>82	<i>TD</i>	62218	184	239	276	
	1980>82	<i>TI</i>	62217	184	239	296	
	1982>86	<i>TD</i>	62063	237	239	277	
	1982>86	<i>TI</i>	63088	237	239	302	
SERIE III <i>Todos modelos</i>	1986>90	<i>D</i>	64057	187	185	410	
FORD							
	<i>Fecha Date</i>	<i>Eje Axle</i>	<i>Referencia Reference</i>	<i>Racor A Fitting</i>	<i>Racor B Fitting</i>	<i>LT</i>	
ESCORT / ORION							
SERIE III <i>Todos modelos</i>	1986>90	<i>TD</i>	62063	237	239	277	

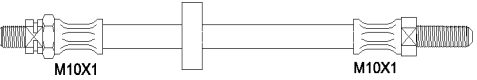
		<i>TI</i>	63088	237	239	302	
SERIE IV <i>Todos modelos</i>	1990>92	<i>DI</i>	63097			420	
		<i>DD</i>	63096			420	
		<i>T</i>	64114	185	187	490	
SERIE V - VI <i>Todos modelos (-1.6 16V)</i>	1990>92	<i>DI</i>	63376			450	
		<i>DD</i>	63375			450	
		<i>T</i>	64114	185	187	490	
SERIE V - VI <i>Todos modelos (-1.3, ABS, 1.6 16V)</i>	1992>94	<i>DI</i>	63377			470	
		<i>DD</i>	63378			470	
		<i>T</i>	64114	185	187	490	
SERIE V - VI <i>Todos modelos 1.3 ABS</i>	1992>94	<i>DI</i>	63379			470	
		<i>DD</i>	63377			470	
	1992>94	<i>T</i>	64114	185	187	490	
SERIE V - VI <i>Todos modelos 1.6 16V</i>	1990>94	<i>DI</i>	63381			470	
		<i>DD</i>	63380			470	
		<i>T</i>	64114	185	187	490	
FORD							
	<i>Fecha Date</i>	<i>Eje Axle</i>	<i>Referencia Reference</i>	<i>Racor A Fitting</i>	<i>Racor B Fitting</i>	<i>LT</i>	
ESCORT / ORION							
SERIE V - VI <i>Todos modelos SW</i>	1990>94	<i>DI</i>	63376			450	

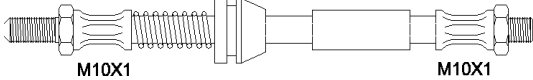
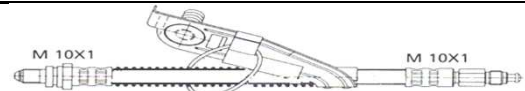
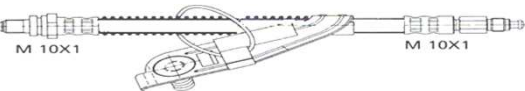
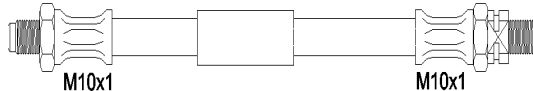
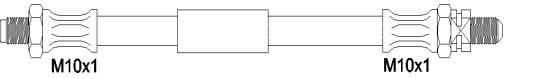
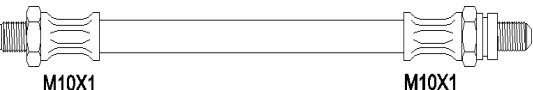
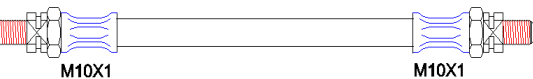
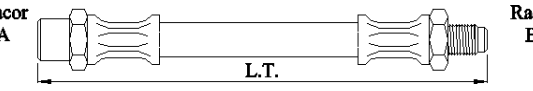
		<i>T</i>	63240	187	237	330	
<i>Todos modelos</i>	2002>	<i>D</i>	65104			520	
		<i>T</i>	64014	250	250	325	
FOCUS							
<i>Todos modelos</i>	1998>	<i>D</i>	63294	187	250	365	
		<i>T</i>	62107	250	250	218	
<i>Lado caliper</i>	98>	<i>T</i>	62108	187	250	185	
FUSION							
	<i>Fecha</i>	<i>Eje</i>	<i>Ref.</i>	<i>A</i>	<i>B</i>	<i>LT</i>	
	08/2002>		65106	242	250	540	
			63408	250	250	345	
GALAXY							
	11/1995>	<i>D</i>	64168	244	250	500	
		<i>T</i>	61181	186	244	190	
GRANADA							
<i>Todos modelos</i>	1978>82	<i>D</i>	65033	203	203	533	
		<i>TD</i>	63049	185	187	370	
FORD							
	<i>Fecha Date</i>	<i>Eje Axle</i>	<i>Referencia Reference</i>	<i>Racor A Fitting</i>	<i>Racor B Fitting</i>	<i>LT</i>	
GRANADA							
<i>Todos modelos</i>	1978>82	<i>TI</i>	62021	185	187	244	

KA									
Todos modelos	1996>	DD	65072			535			
		DI	65073			535			
		T	63260	187	237	390			
MAVERIK									
Todos modelos	1993>	DI	63323			335			
		DD	63322			335			
		T	64203	230	232	470			
		Emb	62168			245			
		Emb	62169			255			
MONDEO									
Todos modelos	1993>96	D	64146	244	250	435			
Todos modelos	1996>00	D	64147	244	250	420			
Todos modelos	1993>96	T	63255	250	250	310			
Todos Berlina (tambor trasero)	09/96>11/00	T	63036	238	250	315			
Todos SW (tambor trasero)	09/96>11/00	T	63037	244	250	348			
FORD									
	Fecha Date	Eje Axle	Referencia Reference	Racor A Fitting	Racor B Fitting	LT			
MONDEO									
Todos Berlina (disco trasero)		T	65105	187	237	580			

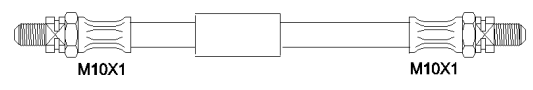
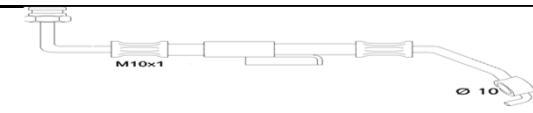
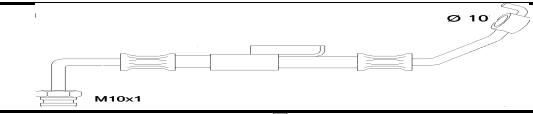
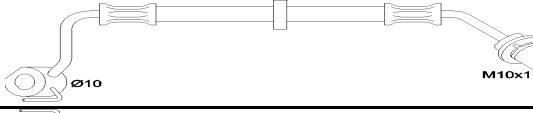
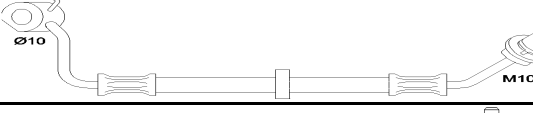
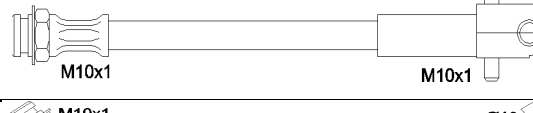

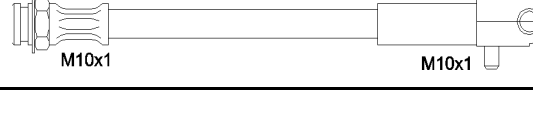
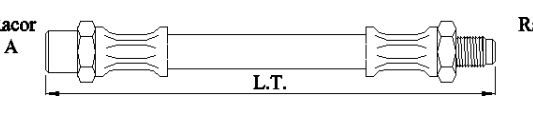
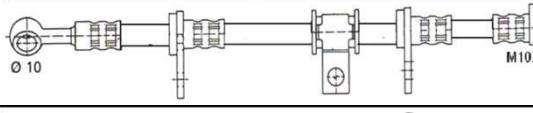
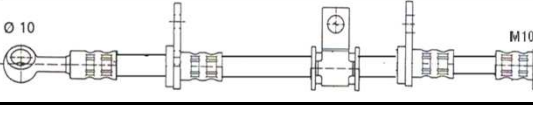
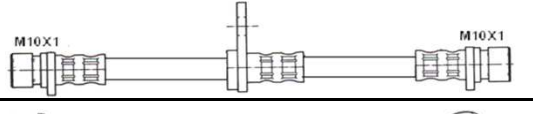
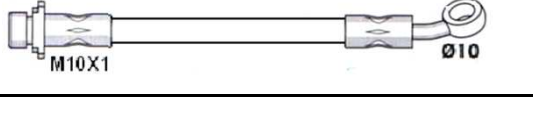
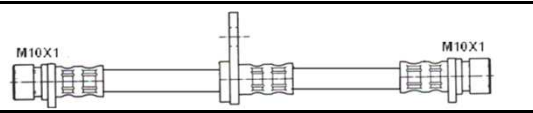
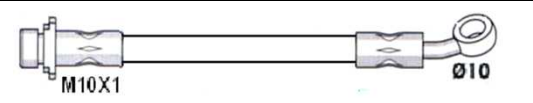



Todos SW (disco trasero)		T	63407	292	250	325	
ORION							
Todos modelos	1983>90	D	64057	187	185	410	
		TD	62063	237	239	277	
		TI	63088	237	239	302	
Todos modelos	1990>93	DI	63376			450	
		DD	63375			450	
		T	64114	185	187	490	
PUMA							
Todos modelos	1997>	DD	63239			413	
		DI	63241			413	
Todos modelos (-ABS)	1997>	T	63260	187	237	390	
Todos modelos (+ABS)		T	63240	187	237	330	
SCORPIO / SIERRA							
Todos modelos	1984>90	D	63202	187	238	350	
Todos modelos (Freno de tambor)		T	63207	237	237	340	
FORD							
	Fecha Date	Eje Axle	Referencia Reference	Racor A Fitting	Racor B Fitting	LT	
SCORPIO / SIERRA							
Todos modelos (Freno de disco lado rueda)		T	62064	185	187	216	

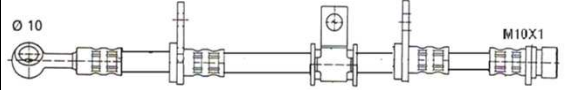
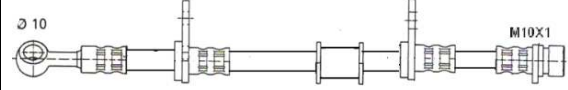
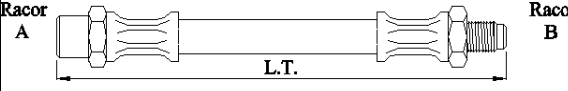
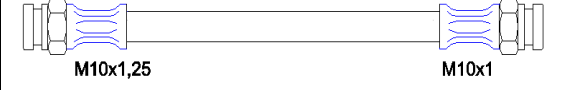
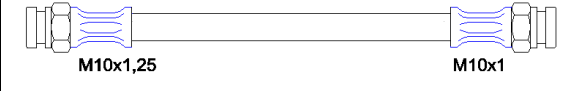
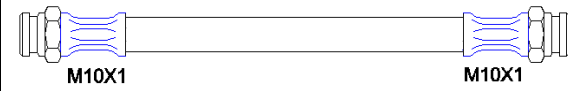
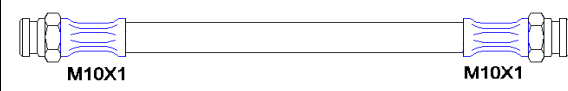
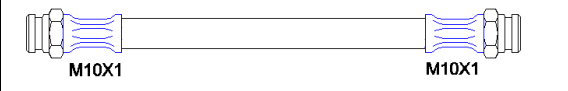
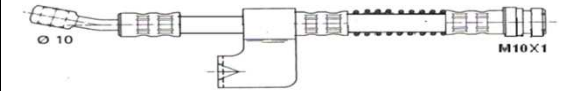
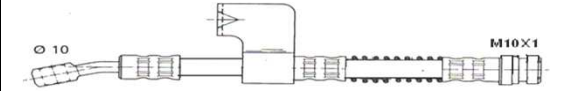
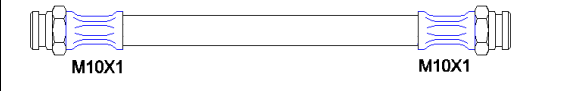
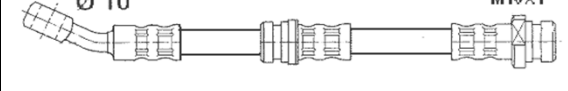
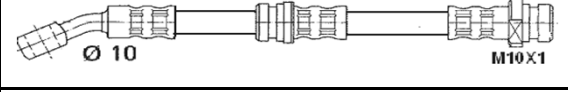
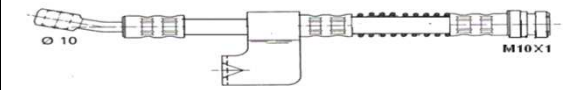
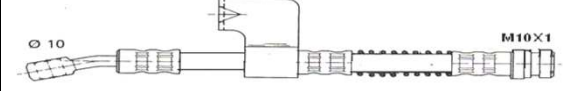

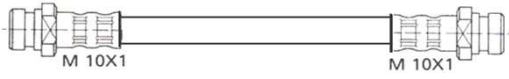
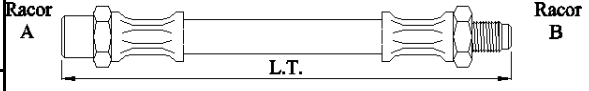
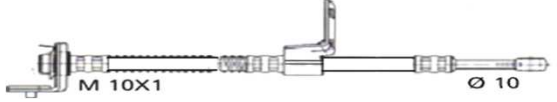

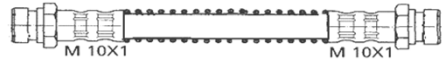
Todos modelos (Freno de disco lado chasis)		T	63203	237	237	328	
TRANSIT							
80, 100, 120	1986>91	DD	64148			429	
		DI	64149			429	
100 L, 130 L	1986>91	DD	62192			285	
		DI	62193			285	
Todos modelos	1986>91	T	64186			447	
130, 160, 190 (Pinzade freno 4 pistones)	1986>91	DD	62194			295	
		DI	62195			295	
		T	64186			447	
HONDA							
	Fecha Date	Eje Axle	Referencia Reference	Racor A Fitting	Racor B Fitting	LT	
ACCORD III							
Todos modelos	11/85>89	DD	66025			663	
		DI	66026			663	
1.6L, 2.0 Exc (chassis 0C054978>) (-Todos) SW	11/85>89	T	63410			342	
2.0, 2.0 16V		T	62341			219	
ACCORD IV							
2.0 16V	1990>93	T	63410			342	
Lado pinza		T	62341			219	

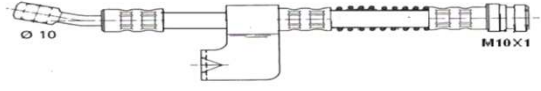
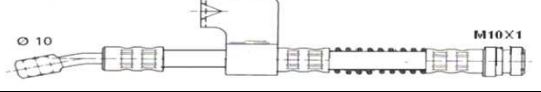
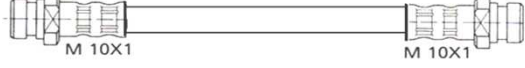
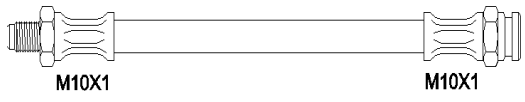

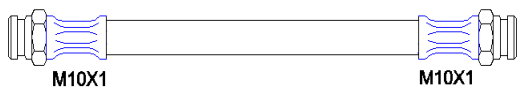
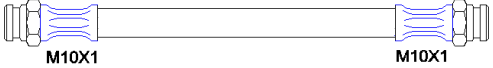
CIVIC III							
Todos modelos	10/87>91	DD	66027			658	
	1987>88	DI	66028			658	
	12/88>91	DI	66029			663	
	10/87>91	T	62342			259	
CIVIC IV							
Todos modelos	95>03/00	DD	66030			685	
		DI	66031			685	
Todos modelos (-ABS)	95>03/00	T	62343			246	
Todos modelos (+ABS)		T	65131			580	

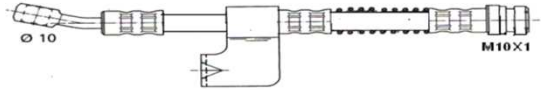
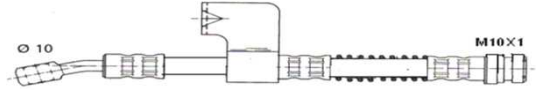
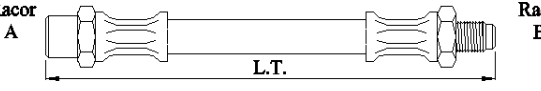
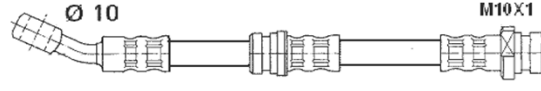
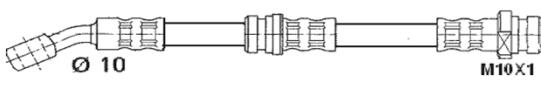
HONDA							
Fecha Date	Eje Axle	Referencia Reference	Racor A Fitting	Racor B Fitting	LT		
CIVIC IV							
Todos modelos	2000>	DD	65129			575	
		DI	65130			575	
		TD	64024			485	
		TI	64025			485	
CRX II							
Todos modelos	89>03/95	DD	66027			658	

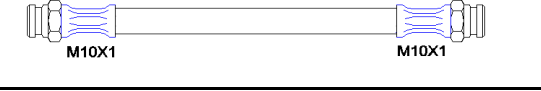
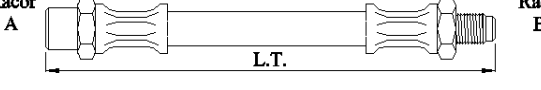
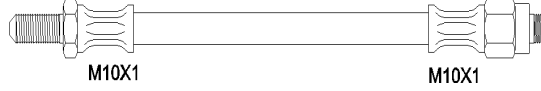
		DI	66028			658	
		DI	66029			663	
HYUNDAI							
	Fecha Date	Eje Axle	Referencia Reference	Racor A Fitting	Racor B Fitting	LT	
ATOS							
Todos modelos	02/98>00	DI	63388			385	
		DD	63387			385	
Todos modelos	02/98>00	TI	63390	191	191	340	
		TD	63389	191	191	300	
Todos modelos	00>	T	62219			285	
COUPÉ							
(-ABS) (+ABS)	1996>99	DI	65107			515	
		DD	65108			515	
		T	62190	233	233	270	
		TI	64018			490	
		TD	64019			490	
		2002>	T	64021			490
LAVITA							
Todos modelos	07/2000>	DI	65109			525	
		DD	65110			525	

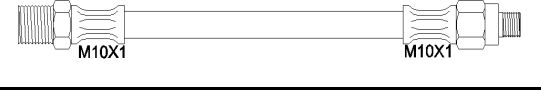
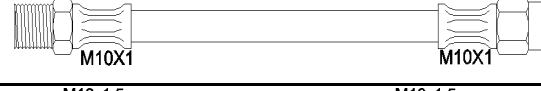
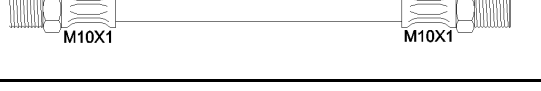
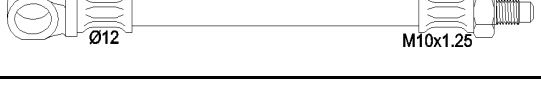
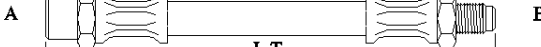

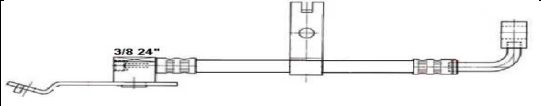
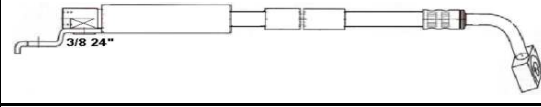

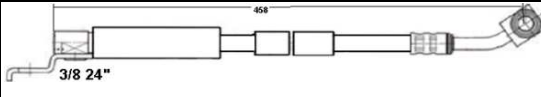
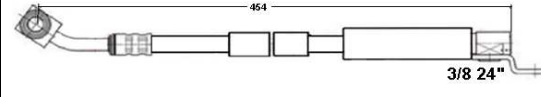
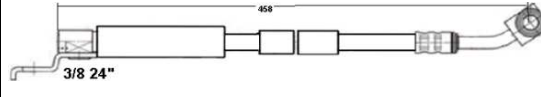
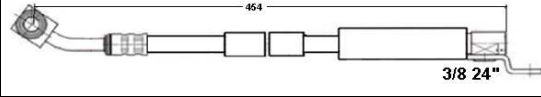
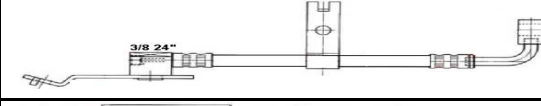
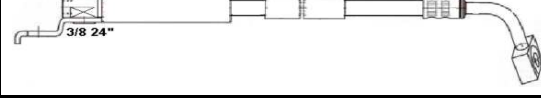
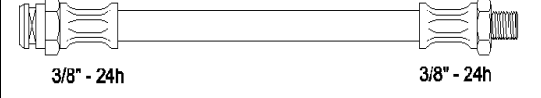
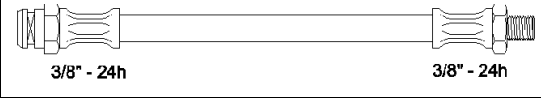
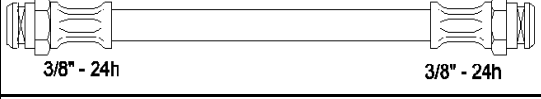
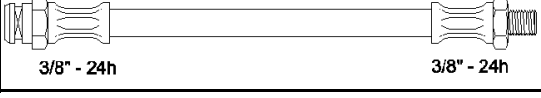
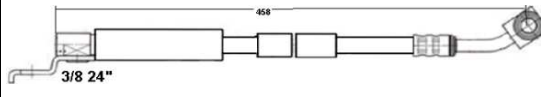
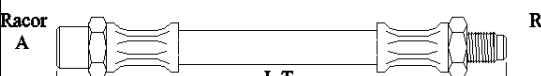
		<i>T</i>	63409			330	
HYUNDAI							
	<i>Fecha Date</i>	<i>Eje Axle</i>	<i>Referencia Reference</i>	<i>Racor A Fitting</i>	<i>Racor B Fitting</i>	<i>LT</i>	
GETZ							
<i>Todos modelos</i>	<i>08/2002></i>	<i>DI</i>	64023			478	
		<i>DD</i>	64022			478	
	<i>08/2002></i>	<i>TI</i>	62351	191	191	230	
		<i>TD</i>	62352	191	191	280	
MATRIX							
	<i>2001></i>	<i>DI</i>	65109			525	
		<i>DD</i>	65110			525	
		<i>T</i>	63409			330	
PONI							
<i>1.2, 1-4, Combi</i>	<i>1978></i>	<i>D</i>	63273	187	233	313	
<i>Con porton trasero</i>	<i>1978></i>	<i>D</i>	61037	187	233	171	
<i>1.3, 1.5, Combi</i>	<i>1989>94</i>	<i>D</i>	62188	187	233	208	
LANTRA							
<i>Todos modelos</i>	<i>1991>96</i>	<i>D</i>	63274	233	233	315	
		<i>T</i>	62190	233	233	270	



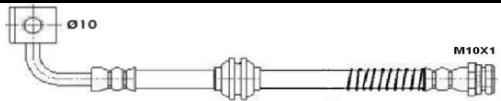
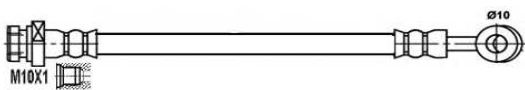
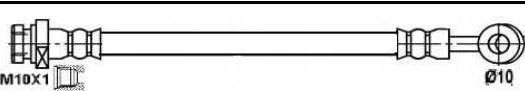
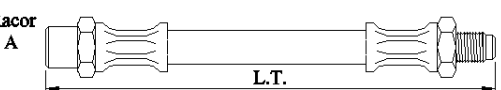
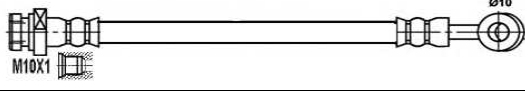
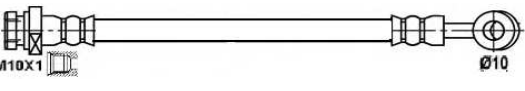
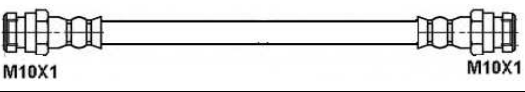
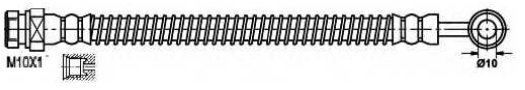
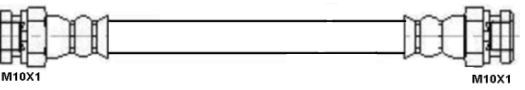
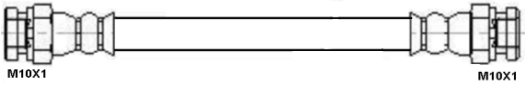
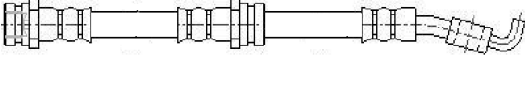
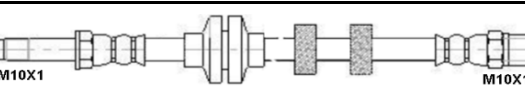
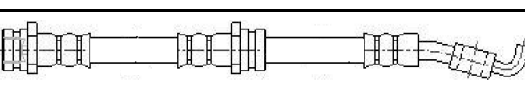

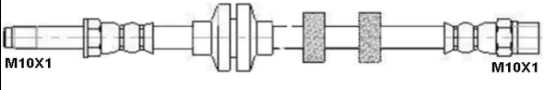
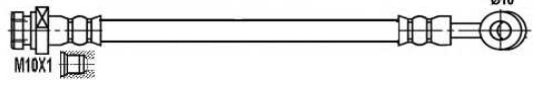
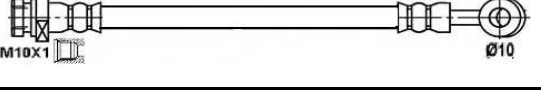
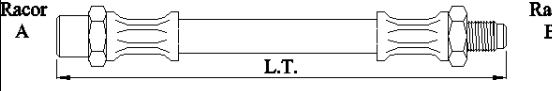
	1996>	DI	65107			515	
		DD	65108			515	
HYUNDAI							
	Fecha Date	Eje Axle	Referencia Reference	Racor A Fitting	Racor B Fitting	LT	
LANTRA							
Todos modelos	1996>	TI	64018			490	
		TD	64019			490	
SONATA							
	1989>	D	62189	187	233	205	
		T	62191	233	233	260	
IVECO							
	Fecha Date	Eje Axle	Referencia Reference	Racor A Fitting	Racor B Fitting	LT	
DAILY							
Daily	1982>85	D	64129	185	193	495	
		T	64131	185	193	465	
30.8, 35.8, 35.10, 40.8 40.10, 45.10	1985>89	D	64132	154	193	490	
		T	64133	154	193	530	
		I	64134	154	154	330	
Daily 50,60,65	85>89	T	64136	049	179	400	
JEEP							

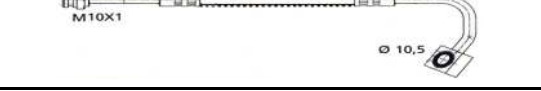
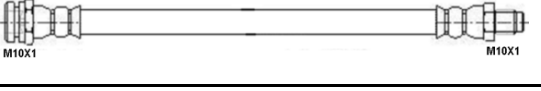
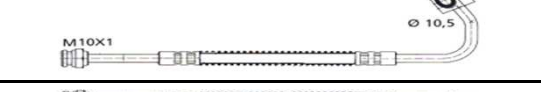

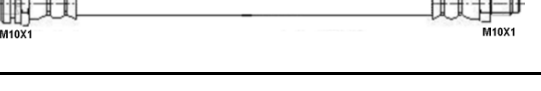
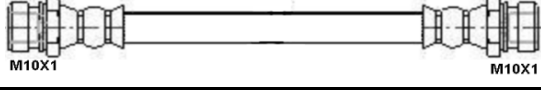
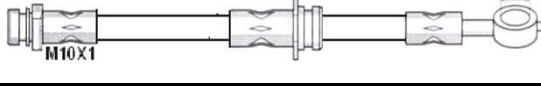
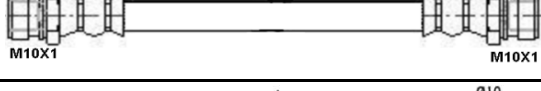
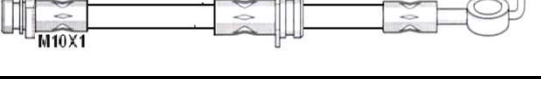

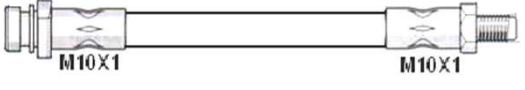
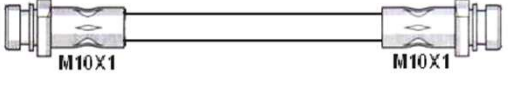
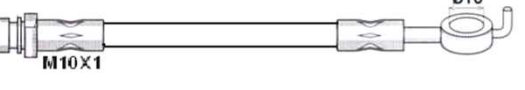
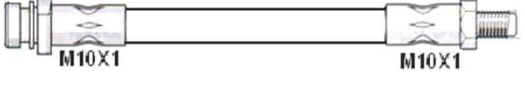
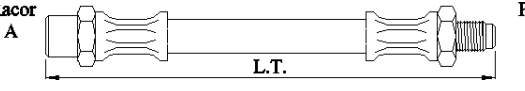
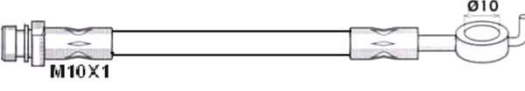
	Fecha Date	Eje Axle	Referencia Reference	Racor A Fitting	Racor B Fitting	LT	
CHEROKEE							
Todos modelos	9/90>	DD	65000			520	
Todos modelos	9/90>	DI	64102			460	
Todos modelos	9/90>	T	63052			350	
2.5 Tdi 4x4	10/96>09/01	DI	64163			458	
	10/96>09/01	DD	64166			454	
2.5 TD	10/93>09/96	DI	64163			458	
	10/93>09/97	DD	64166			454	
GRAN CHEROKEE							
Todos modelos	9/91>4/99	DD	65000			520	
Todos modelos	9/91>4/99	DI	64102			460	
WILLYS							
	01/50>12/58	D	62760	007	010	310	
	01/50>12/58	T	64820	007	010	432	
	01/50>12/58	D	61020	007	007	178	
	01/50>12/58	T	64520	007	010	402	
WRANGLER							
2.5, 4.0	10/96>09/02	DI	64163			458	
JEEP							

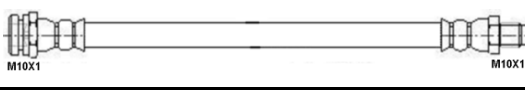
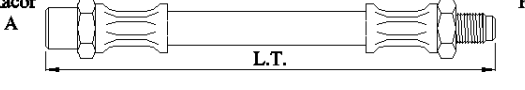
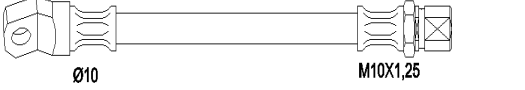

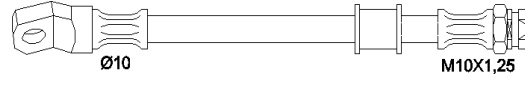
	Fecha Date	Eje Axle	Referencia Reference	Racor A Fitting	Racor B Fitting	LT	
WRANGLER							
2.5, 4.0	10/96>09/02	DD	64166			454	
4.0	08/03>02/06	DI	64163			458	
4.0	08/03>02/06	DD	64166			454	
KIA							
	Fecha Date	Eje Axle	Referencia Reference	Racor A Fitting	Racor B Fitting	LT	
CARENS II							
2.0 CRDi	07/02>	DI	65014			522	
2.0 CRDi sin ABS	07/02>	T	62086			240	
CARENS III							
1.6 CRDi 128	10/10>	DD	65014			522	
1.6 CVVT, 2.0 CRDi 135	08/09>	DD	65014			522	
2.0 CRDi 115	05/07>	DD	65014			522	
2.0 CVVT	09/06>	DI	65014			522	
CARNIVAL							
2.5 V6, 2.9 TD	09/99>10/01	DI	65021			578	
	09/99>10/01	DD	65023			578	
CARNIVAL II							
2.5 V6, 2.9 TD, 2.9CRDi	10/01>	DI	65021			578	

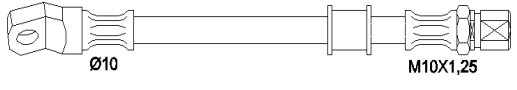
	10/01>	DD	65023			578	
CEE ^ D							
Limousine (06>)							
1.4, 1.6, 2.0 (Todos)	2006>	TI	62089			270	
	2006>	TD	62090			270	
KIA							
				Racor A	Racor B	LT	
	Fecha Date	Eje Axle	Referencia Reference	Racor A Fitting	Racor B Fitting	LT	
CEE ^ D Kombi (07>)							
1.4, 1.6, 2.0 (Todos)	2007>	TI	62089			270	
	2007>	TD	62090			270	
MENTOR II (GB)							
1.6 i 16V	05/2001> 08/2004	T	62086			240	
PICANTO (BA)							
1.0, 1.1	2004>	T	62087			286	
PRIDE							
1.1i	02/91>	TI	63058			322	
1.3 16V	02/90>	TI	63058			322	
	02/90>	D	64101			480	
	02/90>	T	64154			485	
1.3i	02/90>	D	64101			480	

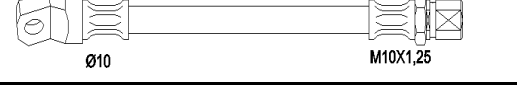
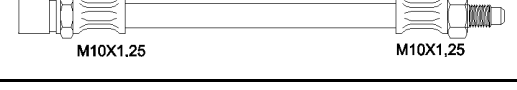
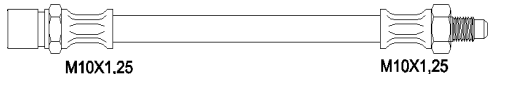
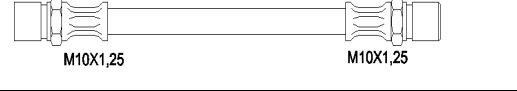
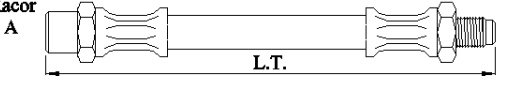
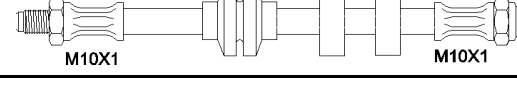
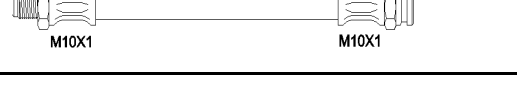
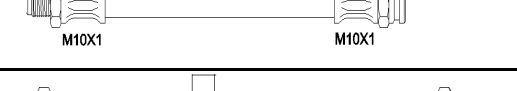
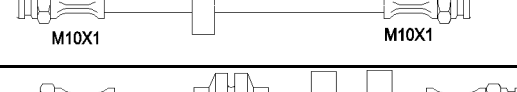

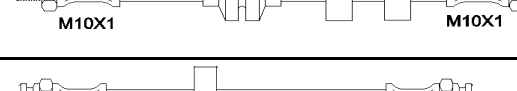
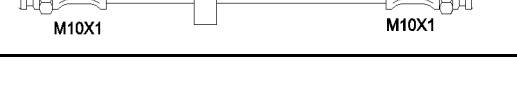

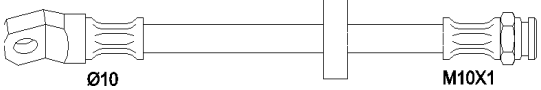
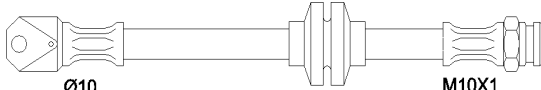
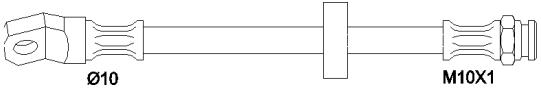
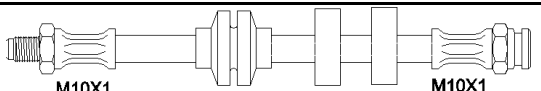
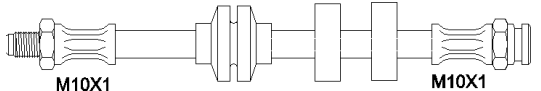
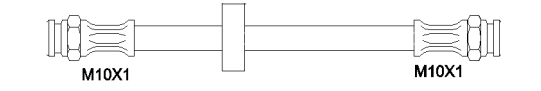
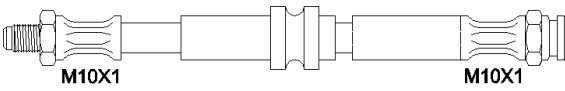
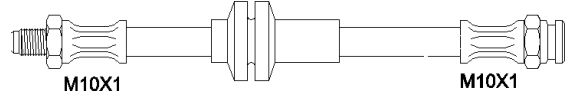
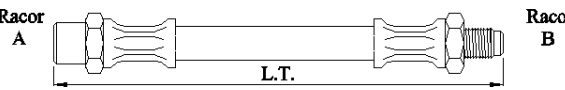
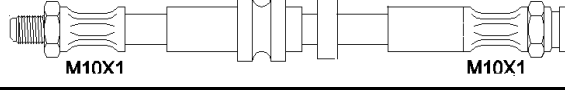
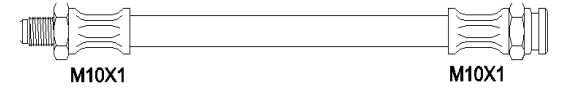
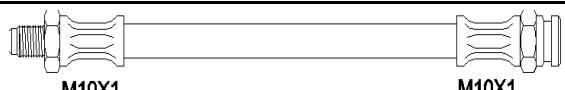
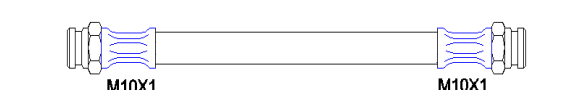
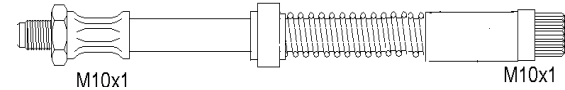

1.3i	02/90>	T	64154			485	
PRO CEE` D							
1.4 16V, 1.6 16V	2008>	TI	62089			270	
		TD	62090			270	
KIA							
	Fecha Date	Eje Axle	Referencia Reference	Racor A Fitting	Racor B Fitting	LT	
RETONA							
2.0 16V	06/00>	DD	63412			390	
	06/00>	DI	63413			390	
	06/00>	T	63414			329	
2.0 TD	06/99>	DD	63412			390	
	06/99>	DI	63413			390	
	06/99>	T	63414			329	
RIO							
Todos modelos	2000>	D	63411			325	
		T	64015			460	
1.3, 1.5 16V	10/00>02/05	D	63411			325	
1.3, 1.5 16V	10/00>02/05	T	64015			460	
SEPHIA							

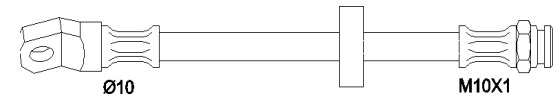
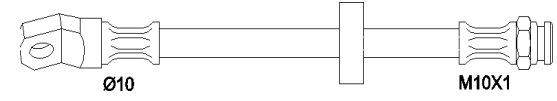
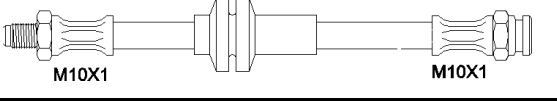
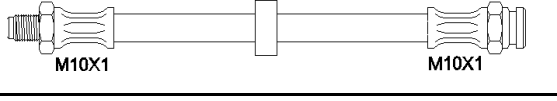
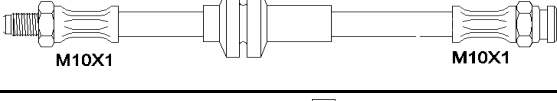
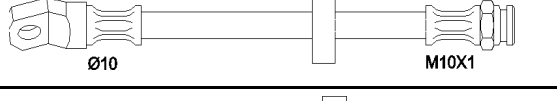
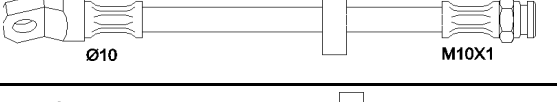
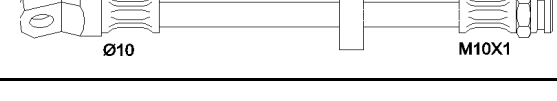
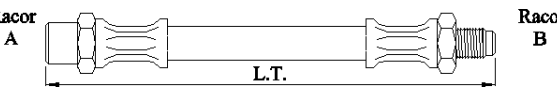
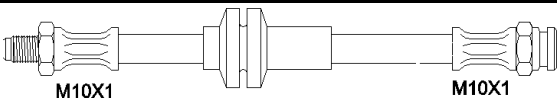
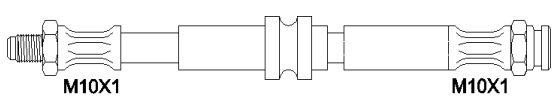
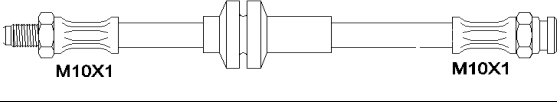
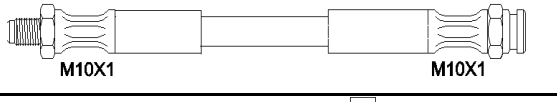
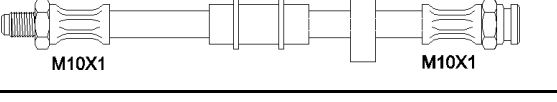
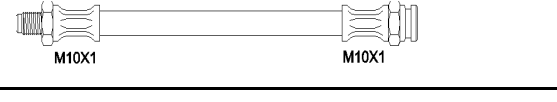
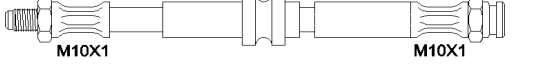
Todos modelos	01/95>	D	64026			463	
Todos modelos (-ABS)	01/95>	T	62029			276	
Todos modelos (+ABS)	01/95>	T	65111			525	
SHUMA							
Todos modelos	10/97>	D	64026			463	
KIA							
				Racor A	Racor B	LT	
	Fecha Date	Eje Axle	Referencia Reference	Racor A Fitting	Racor B Fitting	LT	
SHUMA							
Todos modelos (+ABS)	10/97>	T	65111			525	
SPORTAGE							
Todos modelos	96>	DD	63412			390	
Todos modelos	96>	DI	63413			390	
Todos modelos	96>	T	63414			329	
LADA							
				Racor A	Racor B	LT	
	Fecha Date	Eje Axle	Referencia Reference	Racor A Fitting	Racor B Fitting	LT	
1300, 1600	Fecha	Eje	Ref.	A	B	LT	
Todos modelos	1976>	D	62008	051	132	280	
		T	63015	051	179	305	
NIVA							
Todos modelos	1978>	DS	64184	051	132	495	

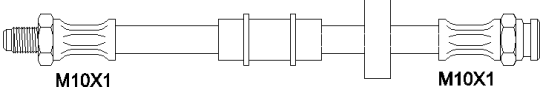
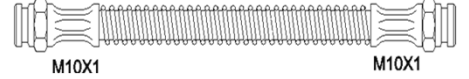
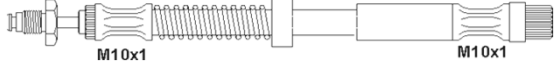
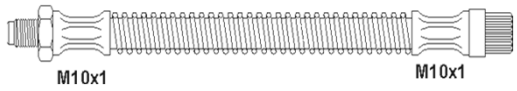

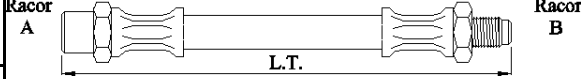
		<i>DI</i>	64058	051	132	440	
		<i>T</i>	63015	132	179	305	
		<i>E</i>	62207	131	246	260	
RIVA							
<i>Todos modelos</i>	1984>94	<i>D</i>	62008	051	132	280	
		<i>T</i>	63015	051	179	305	
SAMARA							
<i>Lada Samara</i>	1986>	<i>D</i>	63275	132	179	340	
		<i>T</i>	62196	132	132	260	
LANCIA							
	<i>Fecha Date</i>	<i>Eje Axle</i>	<i>Referencia Reference</i>	<i>Racor A Fitting</i>	<i>Racor B Fitting</i>	<i>LT</i>	
DEDRA							
<i>Todos modelos</i>	1989>93	<i>D</i>	63091	187	191	390	
<i>(-ABS)</i>	1989>93	<i>T</i>	62085	187	191	210	
<i>(+ABS) Lado Caliper</i>		<i>T</i>	61196	187	191	185	
<i>(+ABS) Lado Chassis</i>		<i>T</i>	62077	191	191	241	
<i>Todos modelos</i>	1994>	<i>DI</i>	63091	187	191	390	
		<i>DD</i>	64091	187	191	412	
		<i>T</i>	62077	191	191	241	
DELTA							

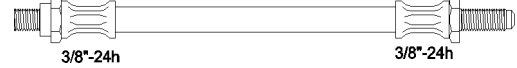
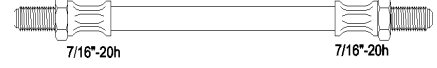
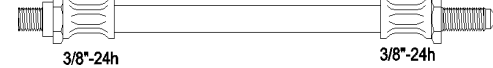
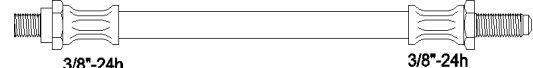
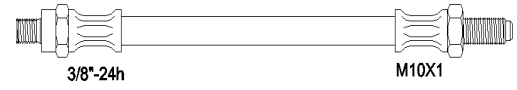
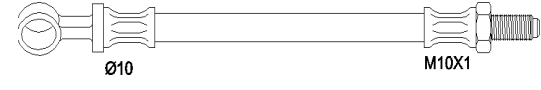
1300, 1500	>1986	D	64187	051	191	464	
	1986>93	D	64137	051	191	469	
		T	64097	051	191	422	
1.4i, 1.6i,	1993>	DI	63091	187	191	390	
		DD	64091	187	191	412	
		T	62077	191	191	241	
KAPPA							
Todos modelos	1994>02	D	65074	187	191	561	
		T	64093	187	191	410	
LANCIA							
	Fecha Date	Eje Axle	Referencia Reference	Racor A Fitting	Racor B Fitting	LT	
LYBRA							
Todos modelos	1999>	D	64145	187	191	434	
		T	63089	187	191	337	
MUSA							
Todos modelos	2004>	D	65103	187	191	520	
		T	61182	191	191	195	
PHEDRA							
Todos modelos	2002>	D	64049	187	227	485	
		T	62187	227	227	272	

PRISMA								
1.3, 1.5	1983>92	D	64187	051	191	464		
		T	64097	051	191	422		
1.6	1983>92	D	64095	187	191	490		
		T	64098	187	191	465		
1.6 IE	1986>92	D	64095	187	191	490		
		T	64097	051	191	422		
1.9D, TD	1984>92	D	64187	051	191	464		
		T	64097	051	191	422		
LANCIA								
	Fecha Date	Eje Axle	Referencia Reference	Racor A Fitting	Racor B Fitting	LT		
THEMA								
Todos modelos	1984>92	D	65052	187	191	587		
	1992>94	D	65074	187	191	561		
	1984>94	T	64093	187	191	410		
Y 10								
1.0, 1.05, Touring 1.1 1.05 Touring, 1.3 GT, 1.3IE	1985>95	D	63226	187	191	365		
		D	64149	187	191	407		
Todos modelos	1985>95	T	62085	187	191	210		
1.1, 1.2 8V	1995>	D	63263	187	191	385		

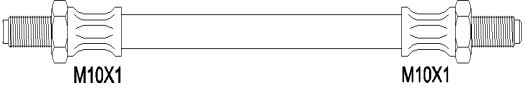
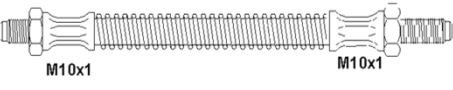
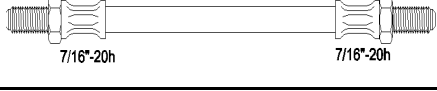
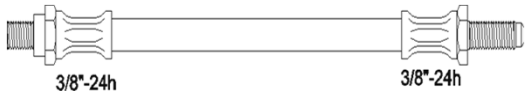
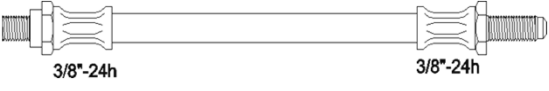
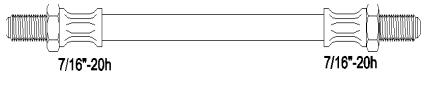
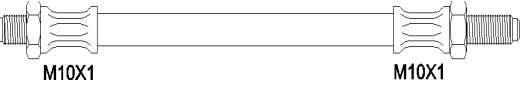
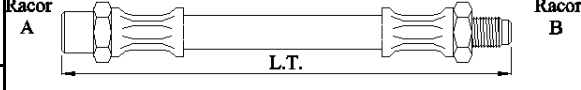
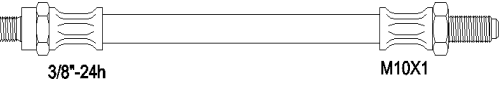
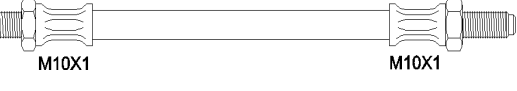
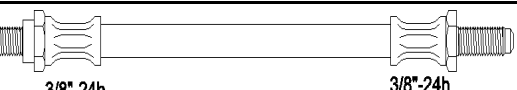
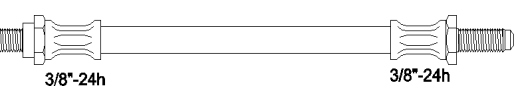
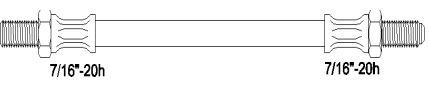
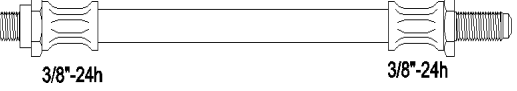
	1995-2003	DI	63345				
	1995-2003	DD	63346				
		T	62049	191	191	207	
1.2 16V, 1.4 12V	1995>	D	64149	187	191	407	
		T	62049	191	191	207	
ZETA							
Todos modelos	1994>	D	65075	242	227	540	
		T	63269	187	227	330	
		I	62187	227	227	272	
LAND ROVER							
	<i>Fecha Date</i>	<i>Eje Axle</i>	<i>Referencia Reference</i>	<i>Racor A Fitting</i>	<i>Racor B Fitting</i>	<i>LT</i>	
88							
Todos modelos 88	>1971	D	65022	044	117	590	
		E	63155	044	117	379	
		E	62043	224	224	256	
88 Serie III	1971>80	D	63155	044	117	379	
		T	64083	044	117	428	
88 Ligero serie III A	1971>80	D	63146	044	223	384	
88 Super Turbo		D	64055	217	223	467	
		I	64076	187	223	450	

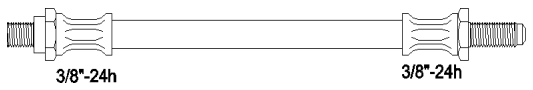
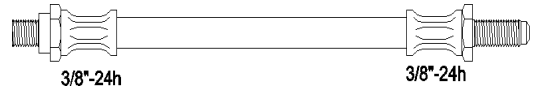
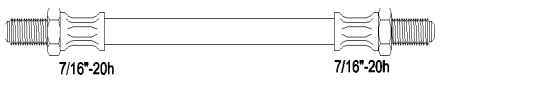
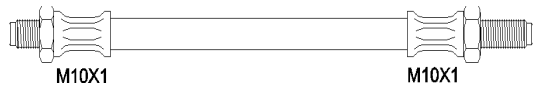
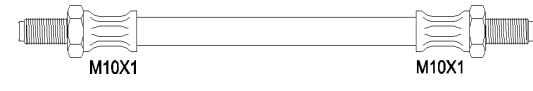
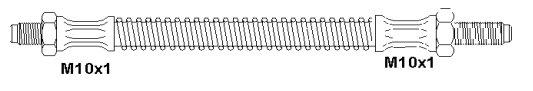
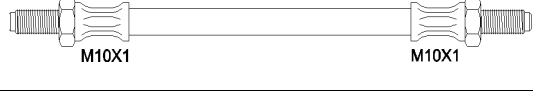
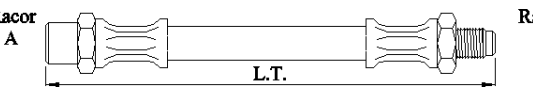
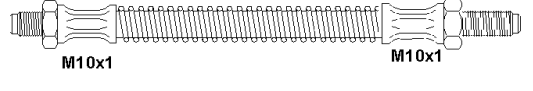
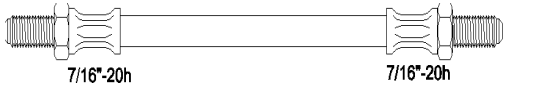
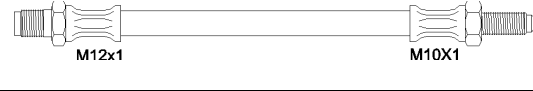
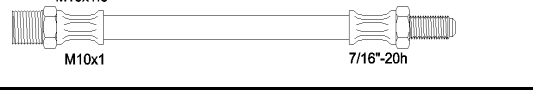
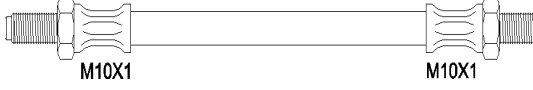
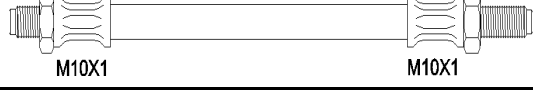



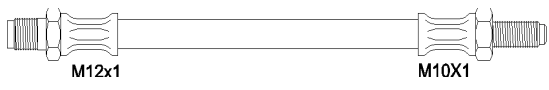
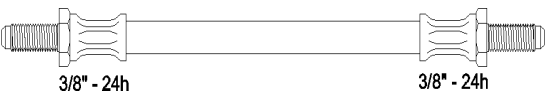
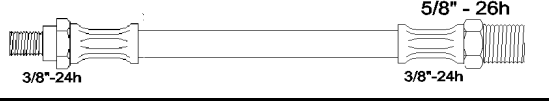
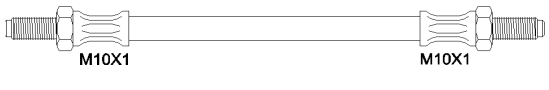
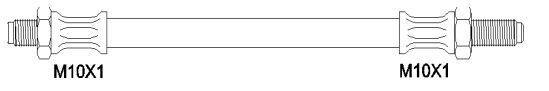
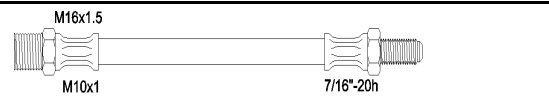
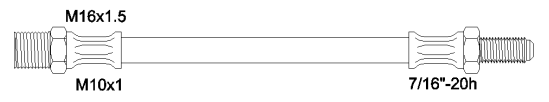
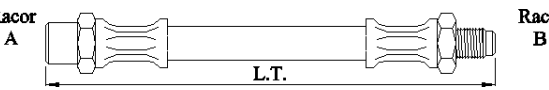
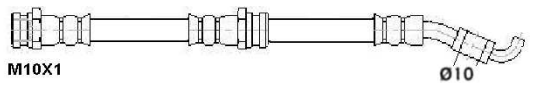
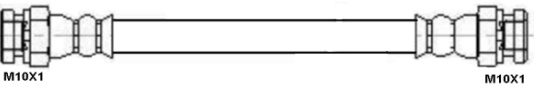
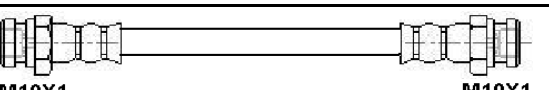
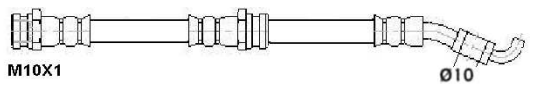
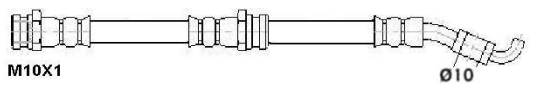
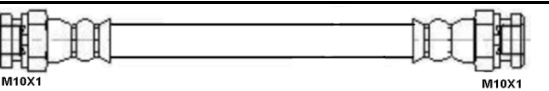
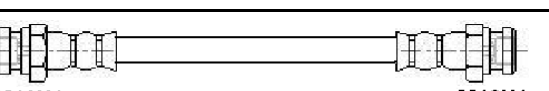

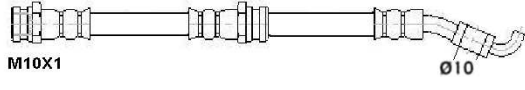
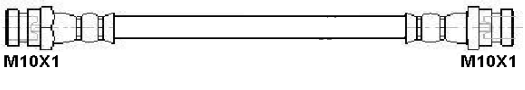
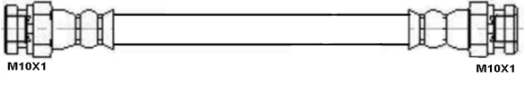
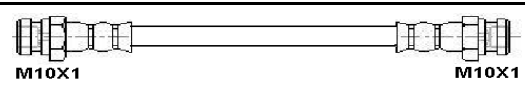
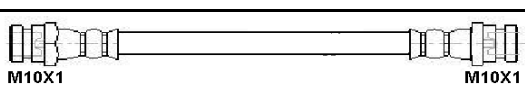
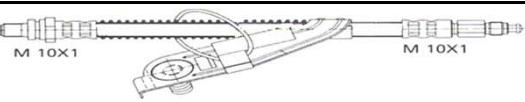
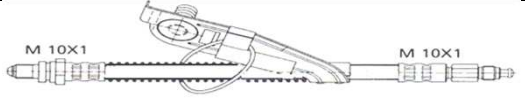
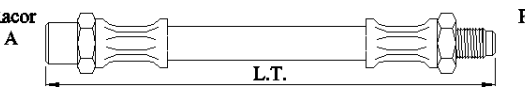
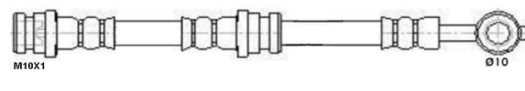
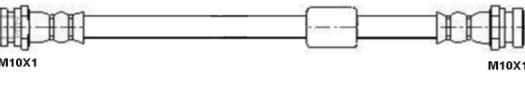
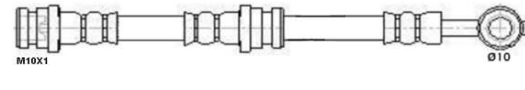
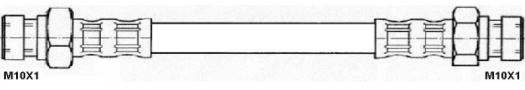
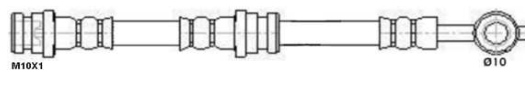
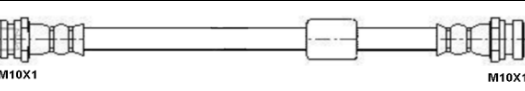

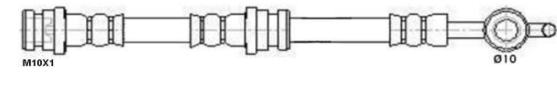
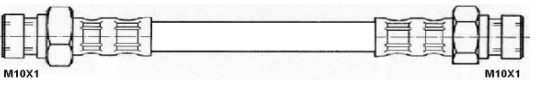
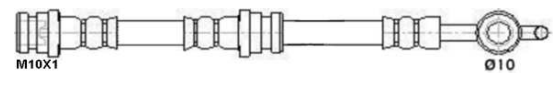
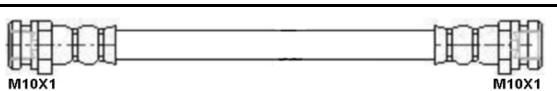
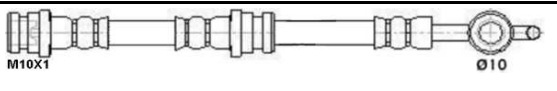
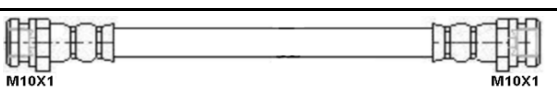
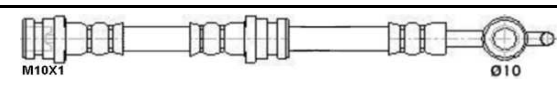
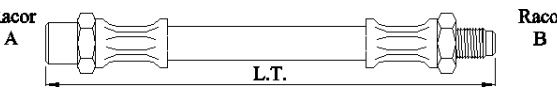
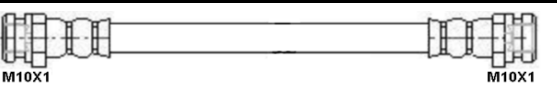
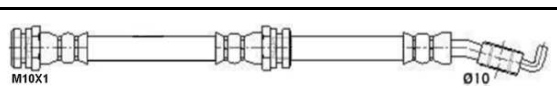
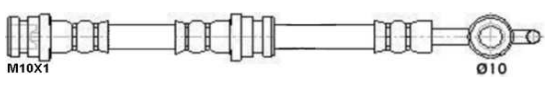
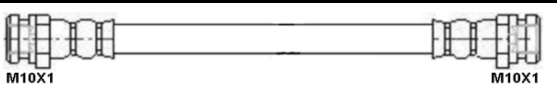
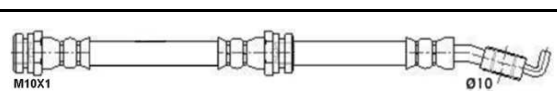
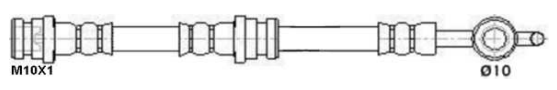
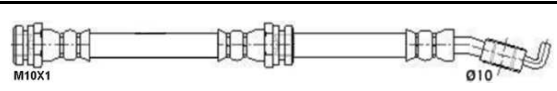
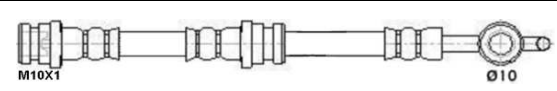

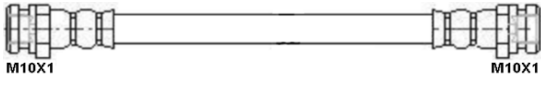
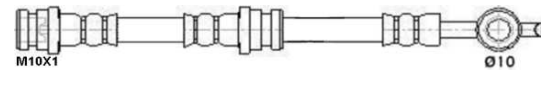
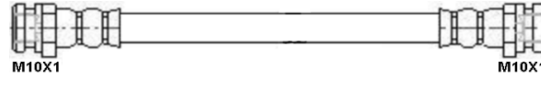
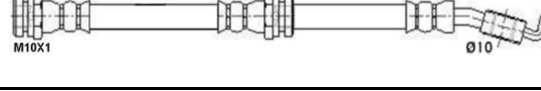
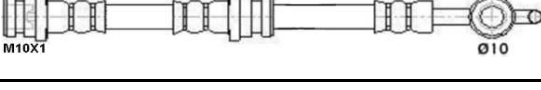
90									
Todos modelos	1983>90	D	64206	223	223	450		M10X1	M10X1
		T	63333	187	223	352		M10x1	M10x1
		E	62043	224	224	256		7/16"-20h	7/16"-20h
109									
Todos modelos	1971>80	D	63154	044	117	391		3/8"-24h	3/8"-24h
		I	64083	044	117	428		3/8"-24h	3/8"-24h
		E	62043	224	224	256		7/16"-20h	7/16"-20h
Todos modelos (excepto Turbo)	1980>84	D	63206	187	223	395		M10X1	M10X1
LAND ROVER									
	Fecha Date	Eje Axle	Referencia Reference	Racor A Fitting	Racor B Fitting	LT			
109									
Turbo		D	63146	044	223	384		3/8"-24h	M10X1
Todos modelos		I	63206	187	223	395		M10X1	M10X1
1300									
Todos modelos		D	63154	044	117	391		3/8"-24h	3/8"-24h
		I	64083	044	117	428		3/8"-24h	3/8"-24h
		E	62043	224	224	256		7/16"-20h	7/16"-20h
2000									
Todos modelos		D	63154	044	117	391		3/8"-24h	3/8"-24h

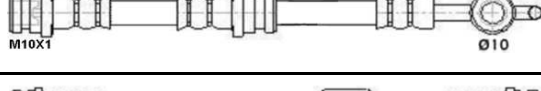
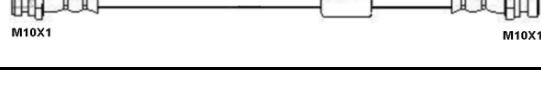
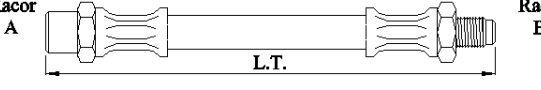

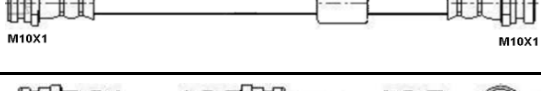
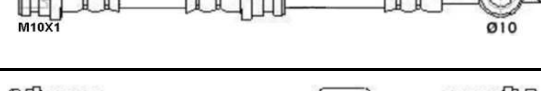
		I	64083	044	117	428	
		E	63155	044	117	379	
		E	62043	224	224	256	
2500							
Todos modelos		D	65091	187	223	590	
DEFENDER							
90	1983>	D	64206	223	223	450	
	83>	T	63333	187	223	352	
110	1983>	D	64206	223	223	450	
LAND ROVER							
							
	Fecha Date	Eje Axle	Referencia Reference	Racor A Fitting	Racor B Fitting	LT	
DEFENDER							
110	1983>	T	64207	187	223	405	
Todos modelos 90, 110, (excepto TDI, V8)		E	63334	224	224	332	
T. Modelos 90, 110, TDI		E	63335	152	224	357	
T. Modelos 90, 110, V8		E	64140	154	224	250	
DISCOVERY							
Todos modelos	1989>92	D	64138	223	223	465	
	89>92	T	64139	187	223	432	
Embrague gasolina	89>92	E	64140	154	224	250	





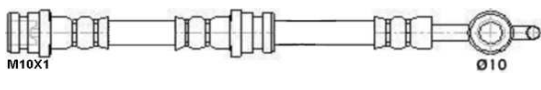

Embrague diesel	89>92	E	64141	152	224	401	
RANGE ROVER							
Todos modelos Medidas Inglesas	1970>81	D	64208	117	117	464	
		T	64209	044	120	423	
Todos modelos Sistema metrico	1981>91	D	64138	223	223	465	
	81>91	T	64139	187	223	432	
Embrague gasolina	81>91	E	64140	154	224	250	
Embrague diesel	81>91	E	64141	152	224	401	
MAZDA							
							
	Fecha Date	Eje Axle	Referencia Reference	Racor A Fitting	Racor B Fitting	LT	
121 I (DA)							
1.1, 1.3	10/87>10/90	D	64172			478	
	10/87>10/90	TI	63058			322	
	10/87>10/90	TD	62092			248	
121II (DB)							
1.1	11/90>10/93	D	64172			478	
1.3 16V	11/90>03/96	D	64172			478	
	11/90>03/96	TI	63058			322	
	11/90>03/96	TD	62092			248	

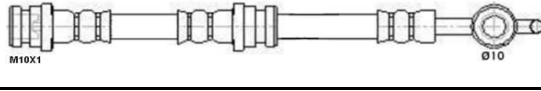
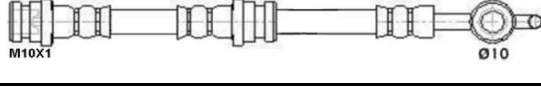
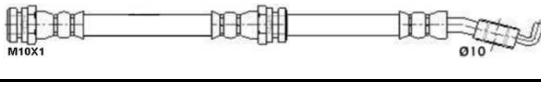
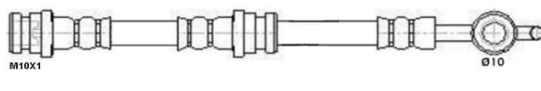
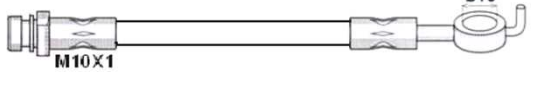
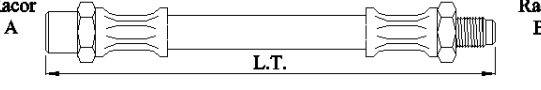
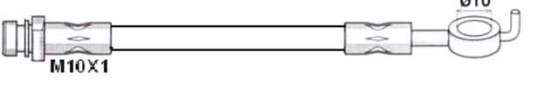
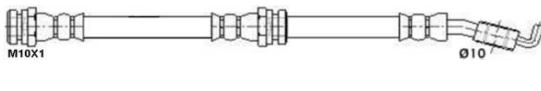
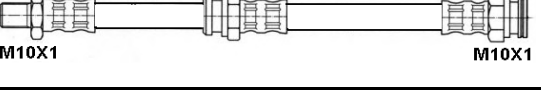
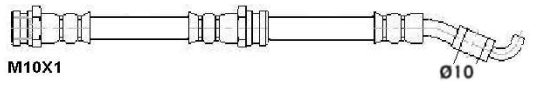
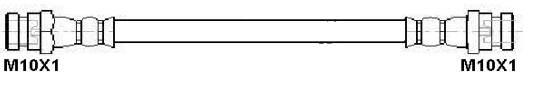
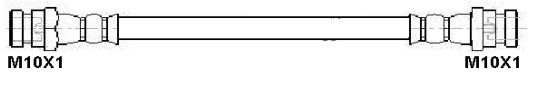

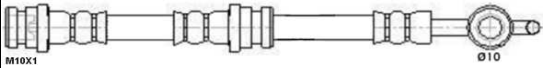
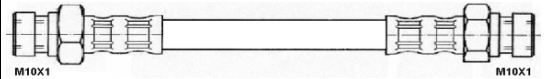

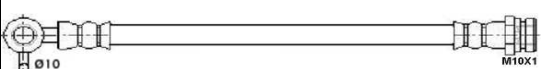
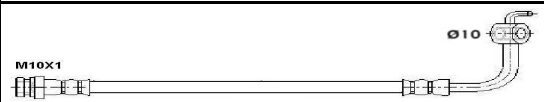
1.3i 16V	11/90>10/93	D	64172			478	
	11/90>03/96	TI	62093			290	
	11/90>03/96	TI	63058			322	
	11/90>03/96	TD	62092			248	
	11/90>03/96	TD	62094			272	
121 III							
1.3, 1.8 D, 1.25	03/96>	DD	63241			413	
	03/96>	DI	63239			413	
MAZDA							
	Fecha Date	Eje Axle	Referencia Reference	Racor A Fitting	Racor B Fitting	LT	
323C IV							
1.3, 1.3 16V 1.6, 1.6 16V, 1.8 16V GT, 1.7D	89>94	D	64153			435	
	89>94	T	62003			281	
323C V							
1.3 16V, 1.5 16V, 1.8 16V	09/94>09/98	D	64153			435	
1.3 16V, 1.5 16V, 1.8 16V	09/94>09/98	T	63100			310	
323 F IV							
1.6, 1.6 16V, 1.8 16V	08/89>07/94	D	64153			435	
	08/89>07/94	T	62003			281	

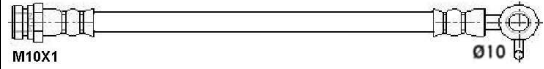
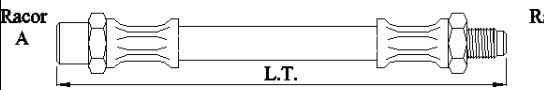
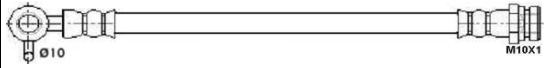

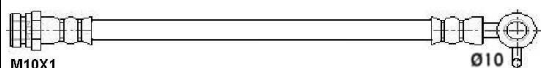
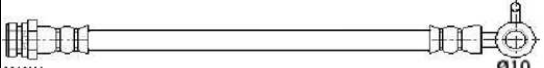
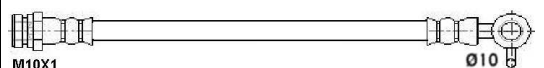
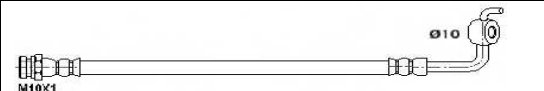
323 F V								
1.5 16V, 1.8 16V 2.0 24V	08/94>09/98	D	64153			435		
	08/94>09/98	T	63100			310		
323 F VI								
1.4	01/01>05/04	D	63060			385		
	01/01>05/04	T	62002			280		
1.4 16V, 1.5 16V	09/98>01/01	D	63060			385		
	09/98>01/01	T	62002			280		
1.6	01/01>05/04	D	63060			385		
		MAZDA						
	Fecha Date	Eje Axle	Referencia Reference	Racor A Fitting	Racor B Fitting	LT		
323 F VI								
1.6	01/01>05/04	T	62002			280		
	01/01>10/03	T	65017			535		
1.9 16V	09/98>09/00	D	63060			385		
	09/98>01/01	T	62002			280		
	09/98>09/00	T	65017			535		
2.0	01/01>05/04	D	63060			385		
	01/01>05/04	T	65017			535		
2.0 D	09/98>09/00	D	63060			385		

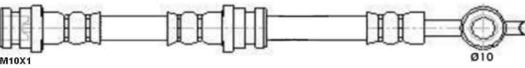
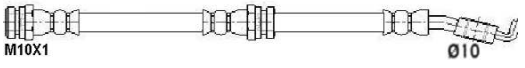

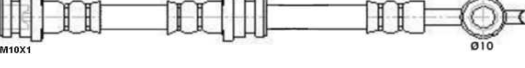
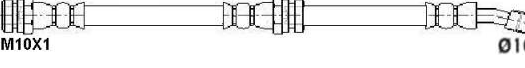

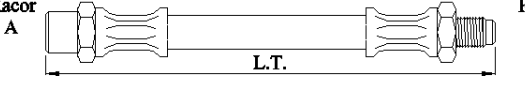
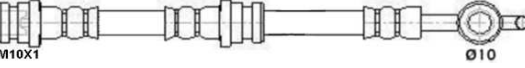
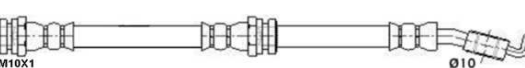
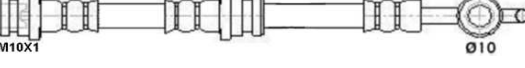
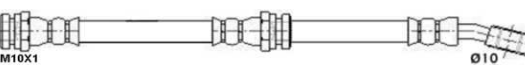
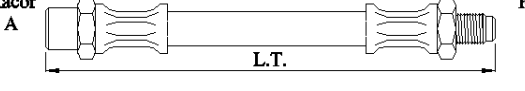
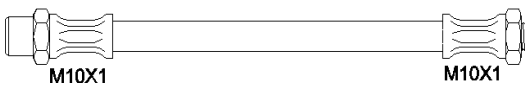
	09/98>05/04	T	62002			280	
2.0 TD	09/98>10/03	D	63060			385	
	09/98>10/03	T	62002			280	
	09/98>10/03	T	65017			535	
323 S VI (BJ)							
1.4	01/01>10/03	D	63060			385	
	01/01>10/03	T	62002			280	
1.4 16V, 1.5 16V	09/98>10/00	D	63060			385	
	09/98>10/00	T	62002			280	
				MAZDA			
	Fecha Date	Eje Axle	Referencia Reference	Racor A Fitting	Racor B Fitting	LT	
323 S VI (BJ)							
1.6	01/01>10/03	D	63060			385	
	01/01>10/03	T	62002			280	
1.9 16V	09/98>05/04	D	63060			385	
	09/98>05/04	T	62002			280	
ABS(+)	09/98>05/04	T	65017			535	
2.0	01/01>05/04	D	63060			385	
	01/01>05/04	T	62002			280	
	09/98>10/03	T	65017			535	

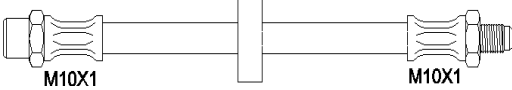
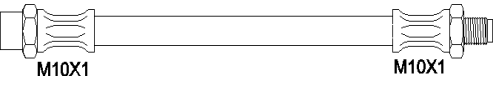
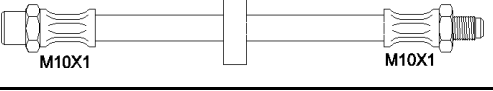
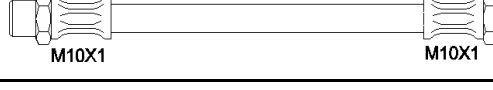
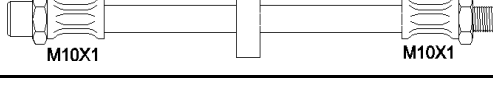
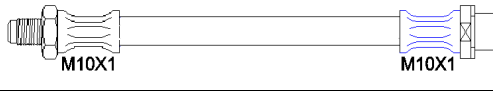
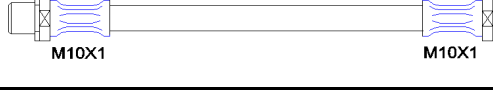
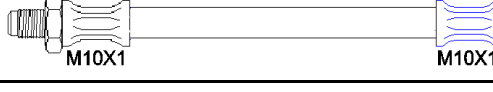

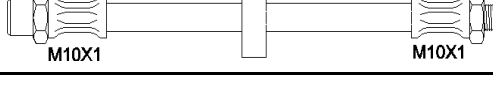
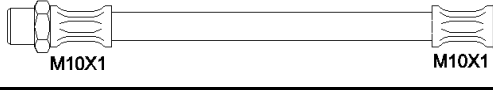
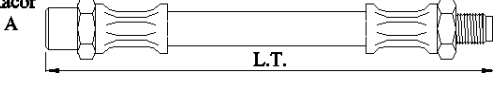
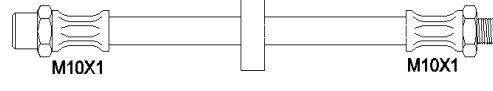
2.0 D, 2.0 TD	09/98>05/04	D	63060			385		
	09/98>05/04	T	62002			280		
(BA) 94-98								
1.3 16V, 1.5 16V, 1.6TD, 1.8, 2.0 24V	94>9/98	D	64153			435		
Todos modelos	02/00>05/04	D	63060			385		
Todos modelos	02/00>05/04	T	65017			535		
626 (GE)								
Todos modelos	92>4/97	D	64153			435		
Todos modelos (-SW)	92>4/98	T	65016			505		
				MAZDA				
626 V (GF)								
1.9, 2.0, 1.9 DI	5/97>	D	64155			420		
1.9, 2.0, 1.9 DI	5/97>	T	65017			535		
929 III								
2.0, 2.2 12V, 2.2i, 3.0, 3.0i	5/87>06/91	D	64173			487		
DEMIO								
Todos modelos	08/98>	D	64172			478		
	08/98>	TI	62093			290		
	08/98>	TD	62094			272		

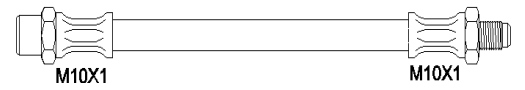
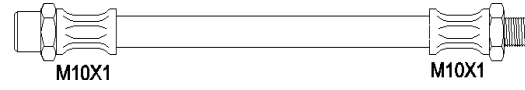
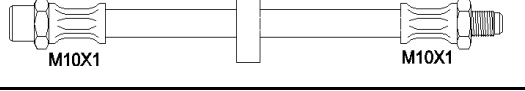
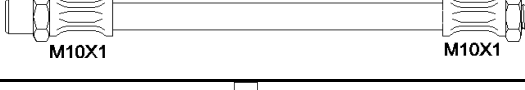
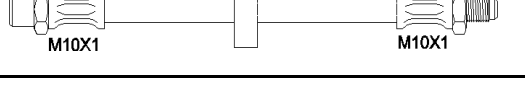
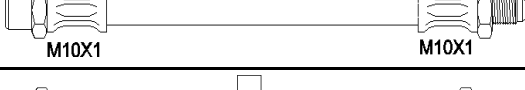
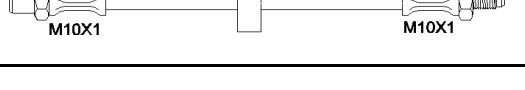

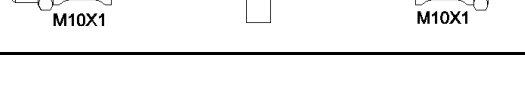
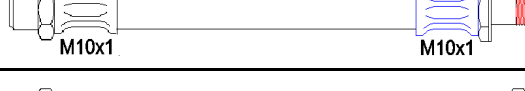
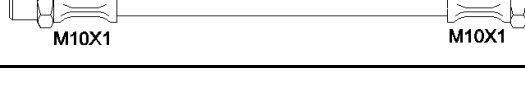
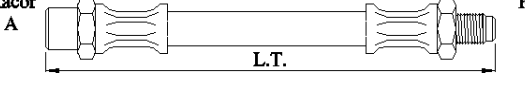

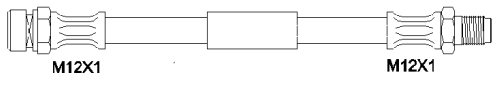
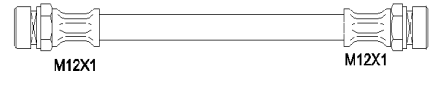
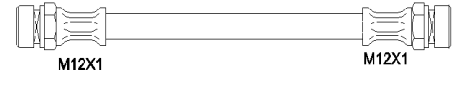
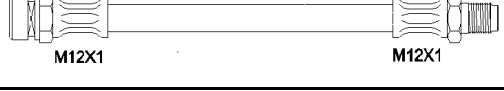
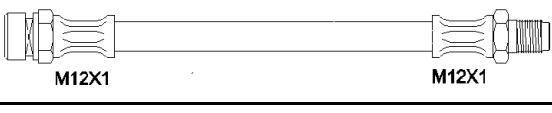
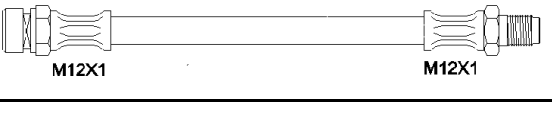
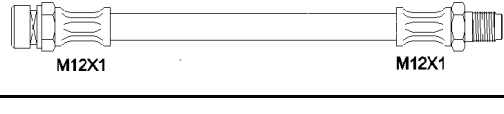
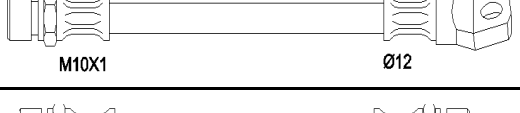
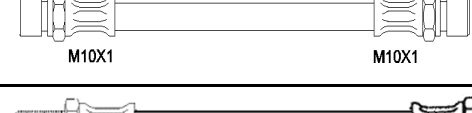
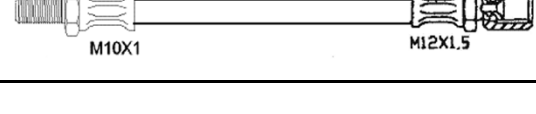
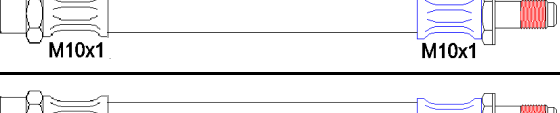
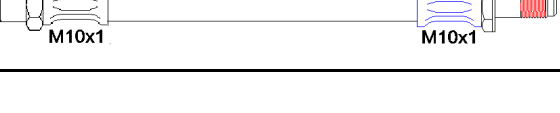
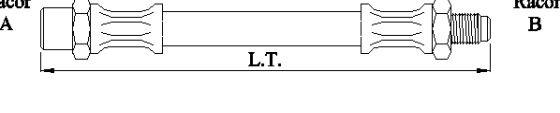

MX3							
1.6i, 1.8i V6	7/91>12/98	D	64153			435	
	7/91>12/98	T	63100			310	
MX5 I							
1.6	05/90>04/98	DI	63105			360	
	05/90>04/98	DD	63106			360	
	05/90>04/98	TI	63108			305	
	05/90>04/98	TD	63111			305	
1.8	09/93>04/98	DI	63105			360	
MAZDA							
	Fecha Date	Eje Axle	Referencia Reference	Racor A Fitting	Racor B Fitting	LT	
MX5 I							
1.8	09/93>04/98	DD	63106			360	
	09/93>04/98	TI	63108			305	
	09/93>04/98	TD	63111			305	
MX5 II							
1.6 16V, 1.8 16V	5/98>10/05	DI	63105			360	
1.6 16V, 1.8 16V	5/98>10/06	DD	63090			368	
1.8	01/98>07/02	DI	63105			360	
Todos modelos	05/1998>	TI	62116			285	

Todos modelos		05/1998>	TD	62117			280		
MX6									
2.0	02/92>02/97	D	64153				435		
	02/92>	T	65024				510		
	02/92>02/97	T	63100				310		
2.5 24V	12/95>02/97	D	64153				435		
	02/92>	T	65024				510		
	02/95>02/97	T	63100				310		
		MAZDA							
	Fecha Date	Eje Axle	Referencia Reference	Racor A Fitting	Racor B Fitting		LT		
PRIMACY									
1.8, 1.9	07/99>07/01	D	63060				385		
	07/99>07/01	T	65017				535		
2.0, 2.0 TD	07/99>07/01	D	63060				385		
	07/99>07/01	T	65017				535		
		MERCEDES							
	Fecha Date	Eje Axle	Referencia Reference	Racor A Fitting	Racor B Fitting		LT		
W 123									
200, 200D, 220, 230, 240D, 240TD	1975>85	D	63391	186	187		375		

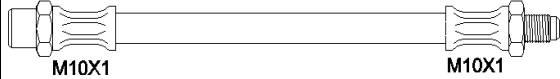
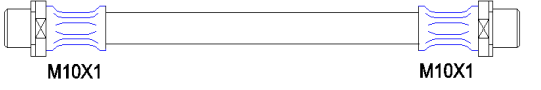

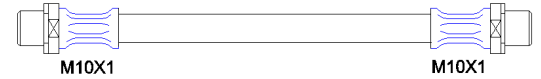
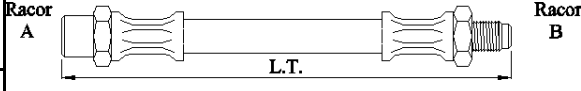
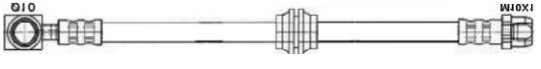
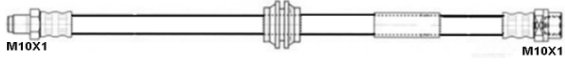
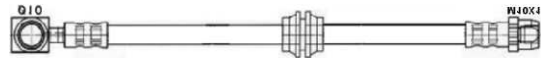
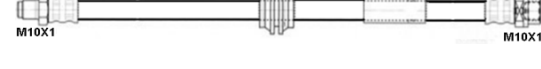
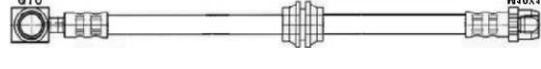
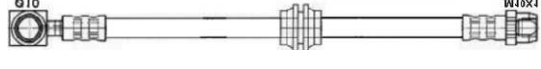
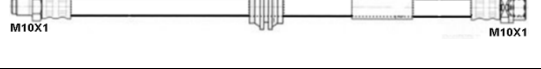
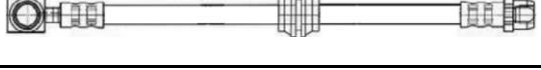
		T	63095	186	187	310	
W124							
260SE, 300SE, 420SE, 500SE, 560SE, 560SEL	1984>93	D	63391	186	187	375	
		T	63095	186	187	310	
W201							
190, 190E 1.8, 190E 2.0, 190E 2.3, 190D 2.5 Turbo	1982>93	D	63391	186	187	375	
		T	63095	186	187	310	
CLASE A (W168)							
A140, A160, A170, A190	1997>	D	63317	187	253	305	
		T	63392	253	253	365	
CLASE C (W202)							
C180, C200D, C220D, C250D	1993>95	D	65114	187	253	505	
	1995>01	D	64210	186	187	410	
	1993>01	T	63095	186	187	310	
CLASE C (W203)							
Todos modelos	05/2000>	D	64210	186	187	410	
MERCEDES							
	Fecha Date	Eje Axle	Referencia Reference	Racor A Fitting	Racor B Fitting	LT	
CLASE C (W203)							
Todos modelos	05/2000>	T	63095	186	187	310	



CLASE E (W124/210)							
Todos modelos (W124)	1985>95	D	63391	186	187	375	
Todos modelos (W210) E200, 200D, 220, 230, 250D, 290TD, 300D	1995>02	D	64210	186	187	410	
Todos modelos Clase E	1985>	T	63095	186	187	310	
CLASE S (W140)							
Todos modelos	1991>	D	65132	186	187	568	
		T	63095	186	187	310	
CLASE SL (R129)							
Todos modelos	1989>	D	63391	186	187	375	
		T	63095	186	187	310	
CLASE SLK (R170)							
Todos modelos	1996>	D	64210	186	187	410	
		T	63095	186	187	310	
CLASE V							
Todos modelos	03/1997>	D	64220	186	244	495	
		T	65115	186	187	525	
MERCEDES							
Fecha Date	Eje Axle	Referencia Reference	Racor A Fitting	Racor B Fitting	LT		
V. COMERCIALES							
Todos modelos F100, N100		D	64016	151	151	405	

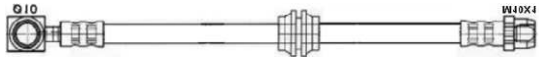
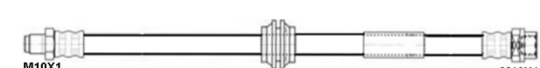
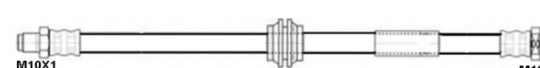
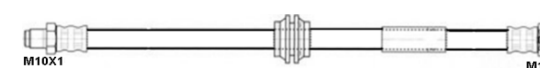
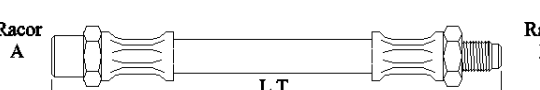
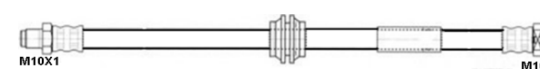
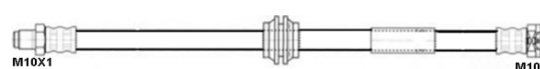
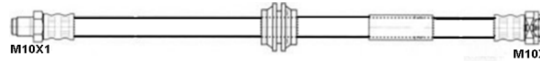
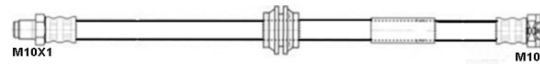
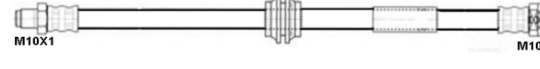
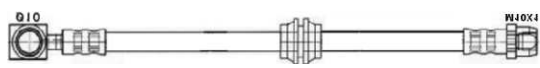
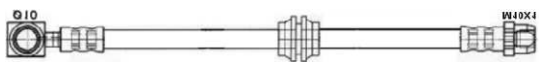
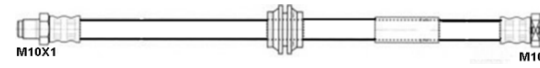
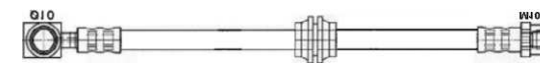
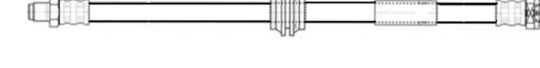

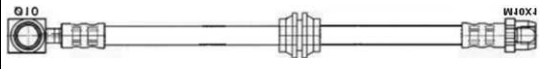
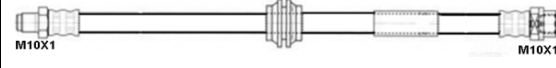
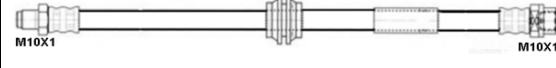
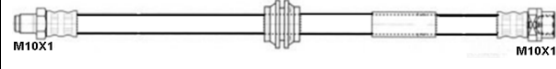
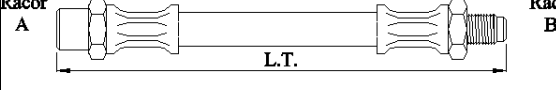
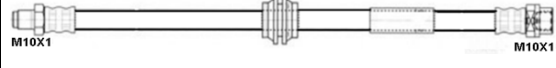
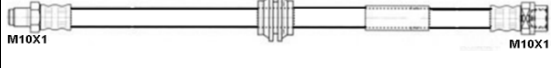
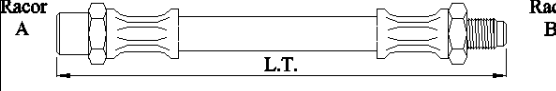
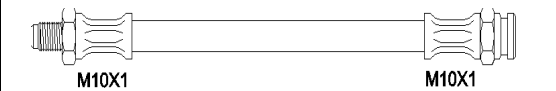
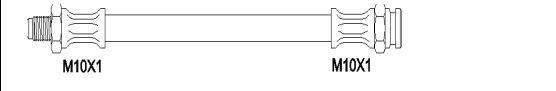

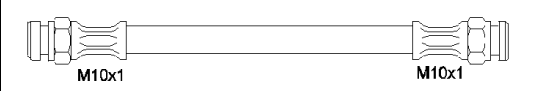
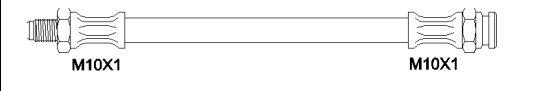

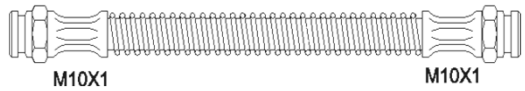
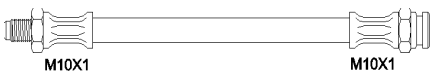
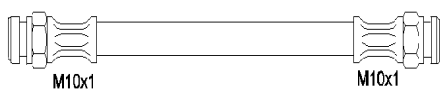
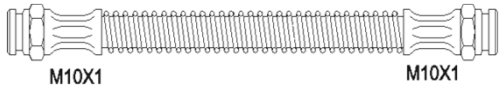
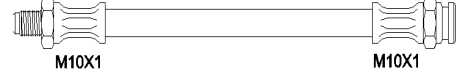
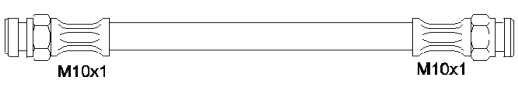
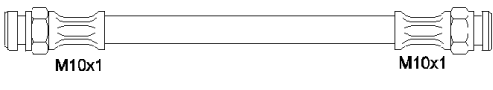
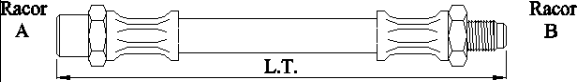
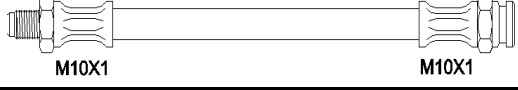
F100, N100 desde chasis 52879> 73527		TI	63291	151	152	325	
F100, N100 desde chasis 73527>		TI	62044	151	151	210	
Todos modelos F100, N100		TD	62069	151	151	264	
Todos modelos F100, N100		E	63290	151	152	325	
L406, L407							
Todos modelos	1980>	D	65560	151	152	526	
		T	64009	151	152	480	
		E	63290	151	152	325	
MB							
Todos modelos	1986>	D	63145	216	221	382	
		T	62042	216	216	280	
Al compensador	86>	I	63298			375	
SPRINTER							
Todos modelos	1994>	D	64164	186	244	404	
	94>	T	64164	186	244	404	
MERCEDES							
							
	Fecha Date	Eje Axle	Referencia Reference	Racor A Fitting	Racor B Fitting	LT	
VITO							
Todos modelos		D	65092	186	244	560	

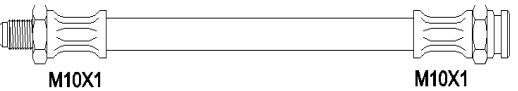
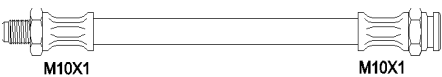
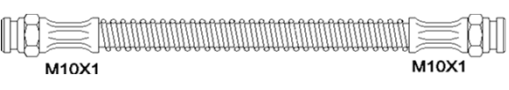
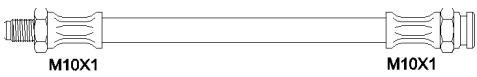

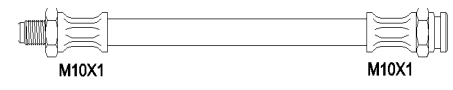
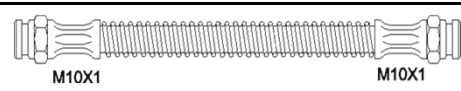
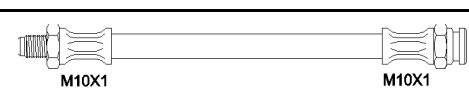

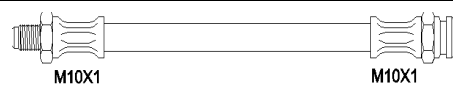
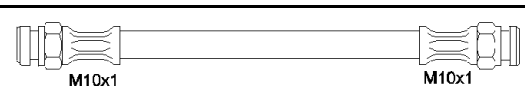
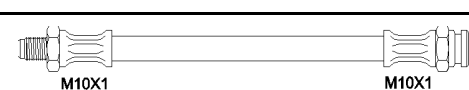
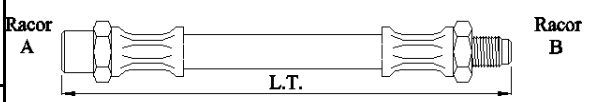

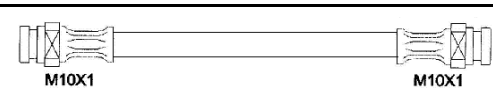
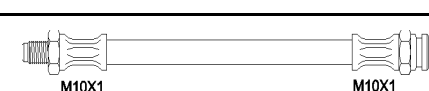

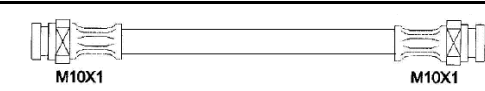
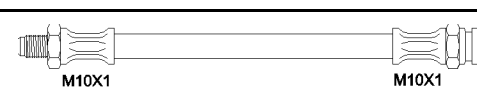

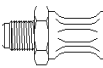
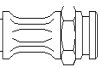

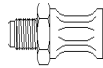
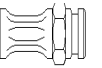
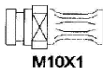
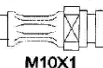
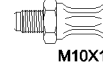

		<i>T</i>	65115	186	187	525		
VANEO								
<i>Todos modelos</i>	2001>	<i>D</i>	63415	253	253	325		
			62344	187	253	258		
			63416	253	253	365		
MINI								
	<i>Fecha Date</i>	<i>Eje Axle</i>	<i>Referencia Reference</i>	<i>Racor A Fitting</i>	<i>Racor B Fitting</i>	<i>LT</i>		
R50, R53								
1.4	04/03>10/06	<i>D</i>	65015			580		
	04/03>10/06	<i>T</i>	64152			442		
1.6 S	11/03>06/05	<i>D</i>	65015			580		
	11/03>06/05	<i>T</i>	64152			442		
<i>Cooper, One</i>	06/01>	<i>D</i>	65015			580		
		<i>T</i>	64151			448		
		<i>T</i>	64152			442		
<i>Cooper, S</i>	03/02>	<i>D</i>	65015			580		
		<i>T</i>	64151			448		
		<i>T</i>	64152			442		
<i>One D,</i>	06/03>	<i>D</i>	65015			580		
		<i>T</i>	64152			442		

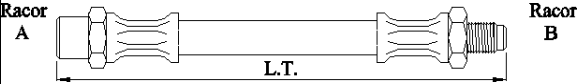
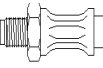



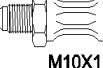

Works	11/03>	D	65015			580	
		T	64152			442	
R56							
Cooper, Cooper S	10/06>	T	64152			442	
Cooper D, One	03/07>	T	64152			442	
MINI							
	Fecha Date	Eje Axle	Referencia Reference	Racor A Fitting	Racor B Fitting	LT	
R56							
John Cooper Works	07/07>	T	64152			442	
CLUBMAN R55							
Cooper, Cooper D, Cooper S	10/07>	T	64152			442	
Jhon Cooper Works	03/08>	T	64152			442	
One	03/09>	T	64152			442	
One D	03/09>	T	64152			442	
CONVERTIBLE R52							
Cooper, One	07/04>	D	65015			580	
		T	64151			448	
		T	64152			442	
Cooper S	07/04>	D	65015			580	
		T	64152			442	

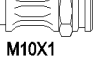
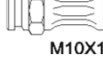
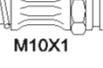

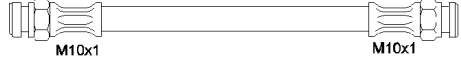
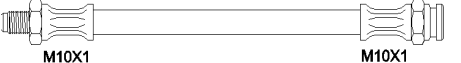
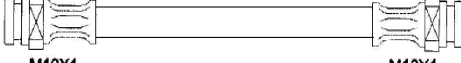
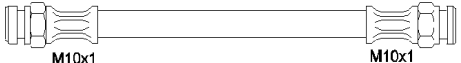

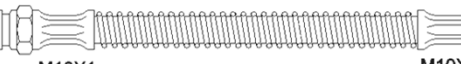
John Cooper Works	07/04>	D	65015			580	
		T	64152			442	
CONVERTIBLE R57							
Cooper, Cooper S	03/09>	T	64152			442	
Cooper D	06/10>	T	64152			442	
MINI							
	Fecha Date	Eje Axle	Referencia Reference	Racor A Fitting	Racor B Fitting	LT	
CONVERTIBLE R57							
John Cooper Works	03/08>	T	64152			442	
One	03/10>	T	64152			442	
MITSUBISHI							
	Fecha Date	Eje Axle	Referencia Reference	Racor A Fitting	Racor B Fitting	LT	
CELESTE							
1600, 2000	1976>81	D	63295	187	266	315	
		T	61037	187	266	171	
COLT I, II							
Todos modelos	1978>84	D	63321	266	266	318	
Todos modelos (Lado caliper)		D	62188	187	266	208	
Todos modelos		T	62199	266	266	270	
Todos modelos (Lado caliper)		T	62203	187	266	259	

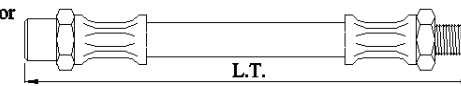
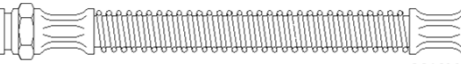
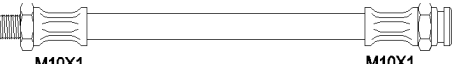
COLT III							
Todos modelos	1984>88	D	63321	266	266	318	
Todos modelos (Lado caliper)		D	62188	187	266	208	
Todos modelos	1984>88	T	62112	266	266	262	
CORDIA (A21 A)							
Todos modelos 1600, 1800	1982>	D	63321	266	266	318	
Todos modelos 1600, 1800 (Lado caliper)		D	62188	187	266	208	
Todos modelos (excepto 1800 4WD)		T	62199	266	266	270	
1800 4WD		T	62111	266	266	244	
MITSUBISHI							
							
Fecha Date	Eje Axle	Referencia Reference	Racor A Fitting	Racor B Fitting	LT		
GALANT							
Todos modelos	1973>80	D	63295	187	266	315	
Todos modelos (Lado caliper)		D	61037	187	266	171	
GALANT II (A16)							
Mitsubishi GALANT 1600 - 2000	1980>84	D	63295	187	266	315	
Todos modelos (Lado caliper)		D	62188	187	266	208	
		T	63321	266	266	318	
Todos modelos (Lado caliper)		T	62203	187	266	259	

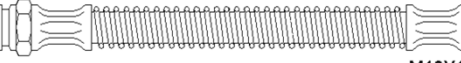
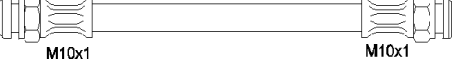
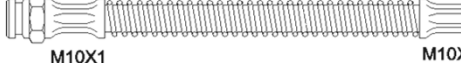
GALANT III (E1 A)									
Todos modelos	1982>87	D	63321	266	266	318		M10X1 M10X1	
Todos modelos (Lado caliper)	80>84	D	62188	187	266	208		M10X1 M10X1	
Todos modelos		T	62114	266	266	265		M10X1 M10X1	
Todos modelos (Lado caliper)		T	62203	187	266	259		M10X1 M10X1	
GALANT IV, V									
Todos modelos	1988>93	D	63321	266	266	318		M10X1 M10X1	
Todos modelos (Lado caliper)	84>88	D	62188	187	266	208		M10X1 M10X1	
Todos modelos		T	62113	266	266	290		M10x1 M10x1	
Todos modelos (Lado caliper)		T	62203	187	266	259		M10X1 M10X1	
		MITSUBISHI							
	Fecha Date	Eje Axle	Referencia Reference	Racor A Fitting	Racor B Fitting	LT			
L200 PICK - UP									
Todos modelos	1986>89	D	62188	187	266	208		M10X1 M10X1	
		D	62115	252	252	221		M10X1 M10X1	
Lado caliper		T	61038	187	266	190		M10X1 M10X1	
L200 (K4 T)									
2.5D	1986>96	D	63321	266	266	318		M10X1 M10X1	
2.5 TD, 2.5TD 4WD, 2.6 4WD		D	62115	252	252	221		M10X1 M10X1	
Lado caliper		T	62188	187	266	208		M10X1 M10X1	

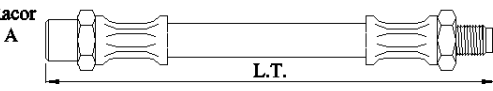

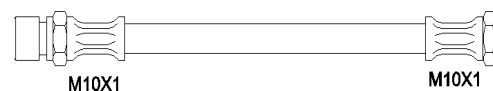
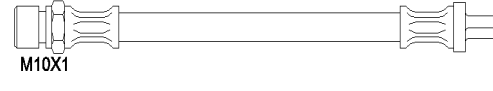
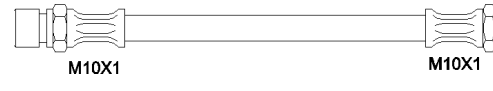
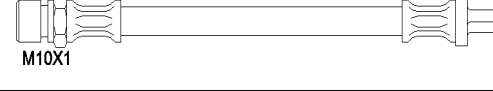
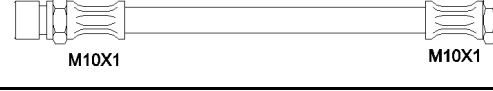
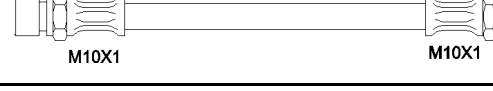
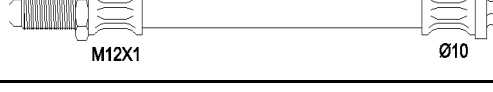
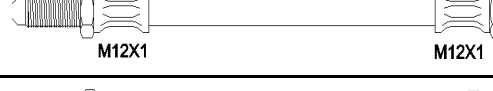
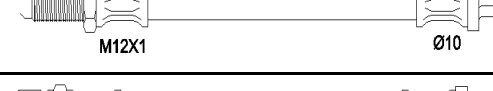
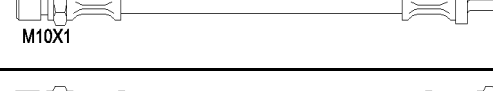
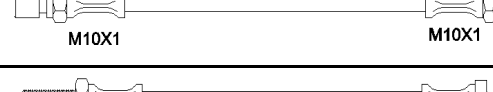
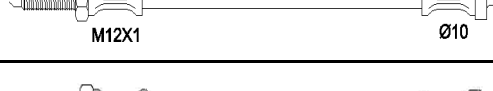
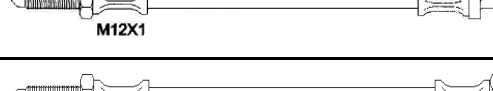
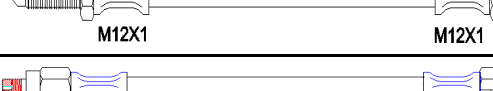

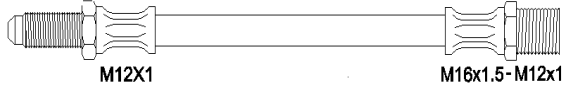
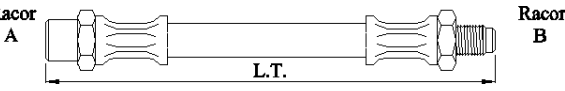
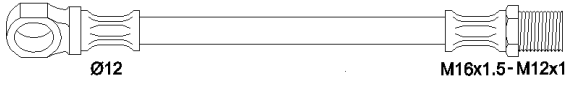
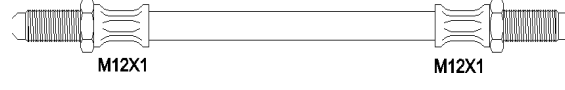
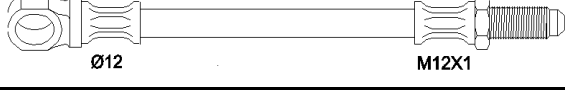
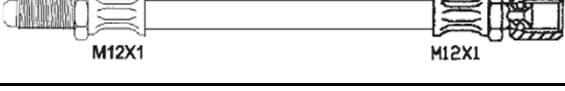
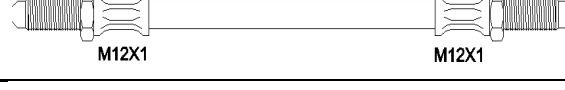
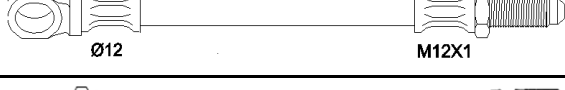
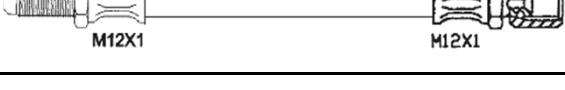
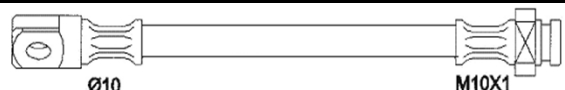
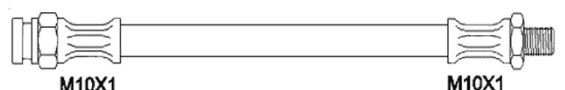
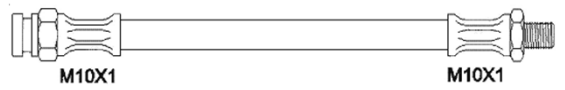
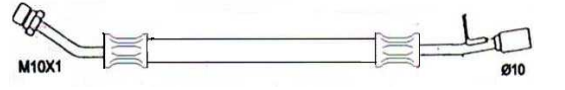
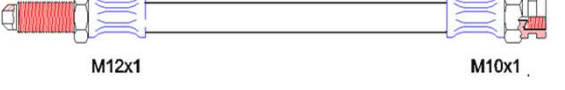
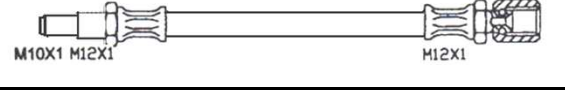

L200 (K6 T)									
2.4	1996>07	D	64051	252	252	425			
2.0, 2.4 (4X4), 2.5, 2.5TD (4X4)	1996>	T	62203	187	266	259			
L200 (K7 T)									
2.4	1996>07	D	64051	252	252	425			
L300									
1.8 DI 4X4 Delantero Exterior	1983>	D	61038	187	266	190			
1.8 DI 4X4 Delantero Exterior		D	62115	252	252	221			
Lado caliper		D	62188	187	266	208			
		T	63417	252	252	370			
		MITSUBISHI							
	Fecha Date	Eje Axle	Referencia Reference	Racor A Fitting	Racor B Fitting	LT			
L400									
Todos modelos	1996>	D	62188	187	266	208			
		TI	63418	252	252	355			
		TD	63419	252	252	330			
LANCER									
	1979>84	D	63295	187	266	315			
	1979>93	D	62188	187	266	208			
	1979>93	D	63321	266	266	318			

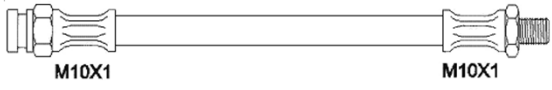
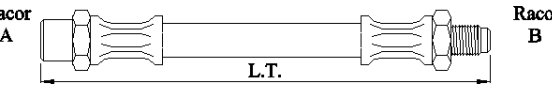
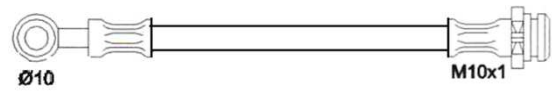

Lado caliper		T	62199	266	266	270	
		T	62188	187	266	208	
MONTERO / PAJERO							
Intermedio	1982>91	D	62115	252	252	221	
		D	62111	266	266	244	
	Lado caliper	D	62345	187	266	245	
	Lado caliper	T	62346	187	266	220	
		T	63320	266	266	370	
		T	62199	266	266	270	
MITSUBISHI							
							
	Fecha Date	Eje Axle	Referencia Reference	Racor A Fitting	Racor B Fitting	LT	
SPACE WAGON							
Lado caliper	83>	D	63321	266	266	318	
	83>	T	62188	187	266	208	
	83>	T	62199	266	266	270	
SPACE WAGON							
2000 4WD		D	63321	266	266	318	
		T	62111	266	266	244	
2000 GLXi		D	63321	266	266	318	

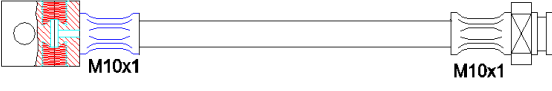
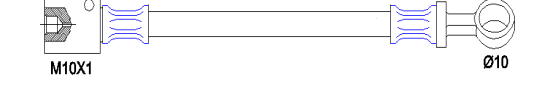
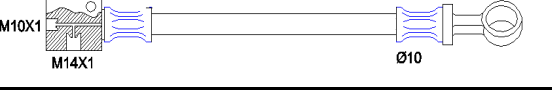
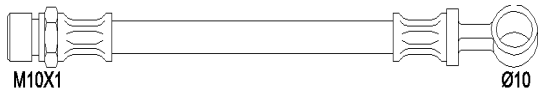
Lado caliper		D	62188	187	266	208	
NISSAN - M.IBERICA							
	Fecha Date	Eje Axle	Referencia Reference	Racor A Fitting	Racor B Fitting	LT	
AVIA, EBRO							
Avia 1000, Ebro F260 Sin freno de disco Con freno de disco	>1982	D	64053	216	217	420	
	1983>	D	64054	216	218	406	
		T	64052	216	140	455	
		I	64054	216	218	406	
Avia 1250 Ebro F275 Sin freno de disco Con freno de disco Con freno de disco	>1982	D	64053	216	217	420	
	1983>	D	64054	216	218	406	
		I	64054	216	218	406	
Avia 1600 Ebro L35 Ebro L35.9	1981>	D	66021	215	217	666	
		T	65041	215	215	552	
		E	64211	215	217	400	
Avia 2000 Ebro F350	>1982	D	65042	216	217	502	
		T	64054	216	218	406	
Avia 2000 Ebro L45	1982>86	D	66021	215	217	666	
Avia 2000 Ebro L45.9	1990>	D	66013	215		547	
	90>	T	65041	215	215	552	
Avia 2500		D	65096	193	248	580	

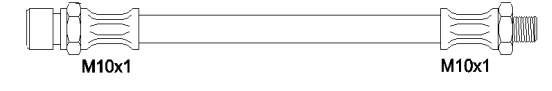
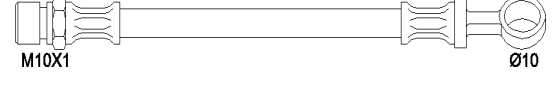
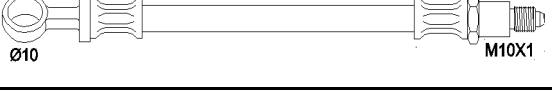
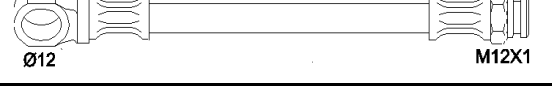
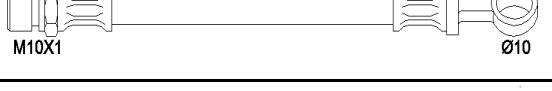
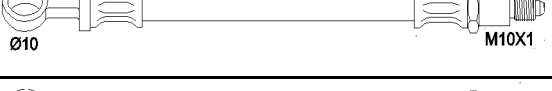

		T	65056	215	248	580	
NISSAN - M.IBERICA							
Fecha Date	Eje Axle	Referencia Reference	Racor A Fitting	Racor B Fitting	LT		
AVIA, EBRO							
AVIA 3000		D	65046	049	248	565	
Avia 3600 Ebro L60	>1984	D	65041	215	215	552	
		E	65065	049	215	552	
		I	65083			545	
Avia 5600 Ebro L80	>1984	D	65041	215	215	552	
		E	65065	049	215	552	
		I	65083	215		545	
CABSTAR							
Cabstar		D	63421	231	232	310	
		T	63422	266	234	340	
		E	63312	266	234	310	
ECO T							
Eco T ECO T cabina vasculante		D	65079			395	
		I	65116	215	234	580	
		I	65112				
MIRA (K10)							

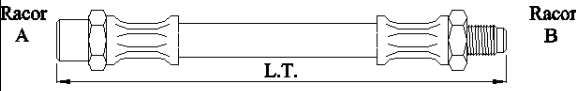
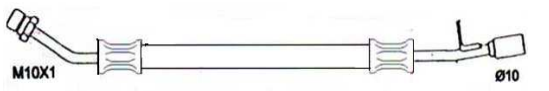
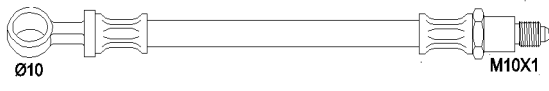
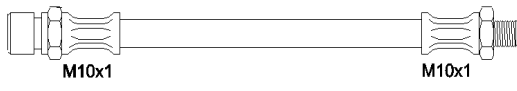
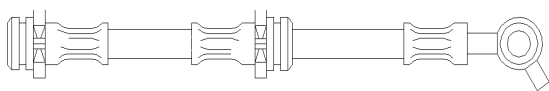
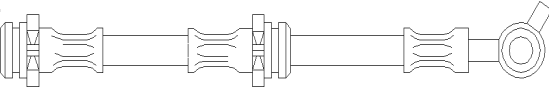
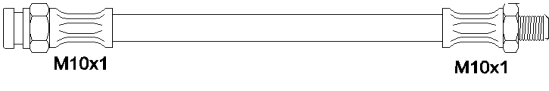
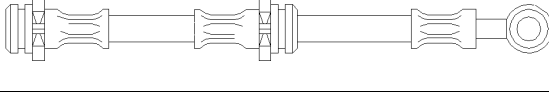
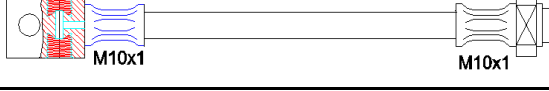
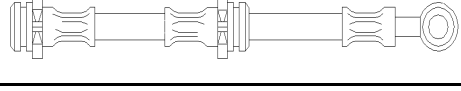
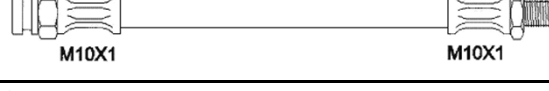
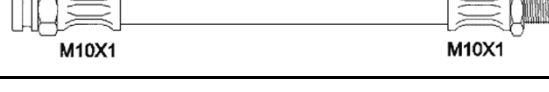
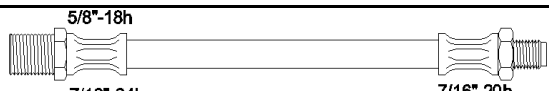
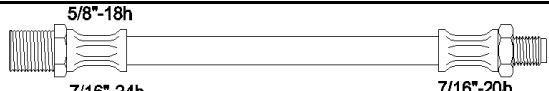

Todos modelos	12/1982>89	D	65133			543	
NISSAN - M.IBERICA							
	Fecha Date	Eje Axle	Referencia Reference	Racor A Fitting	Racor B Fitting	LT	
MIRA (K10)							
Todos modelos	1989>92	D	65134			540	
	1982>92	T	62347	247	247	293	
MIRA (K11)							
Todos modelos (-ÁBS)	1992>	D	64238			467	
Todos modelos (+ÁBS)		D	64239			483	
Todos modelos (-ÁBS)		T	62348	247	247	218	
Todos modelos (+ÁBS)		T	62349	276	247	222	
PATROL							
Todos modelos	1983>	DI	64077	229	230	430	
		DD	63085	231	232	352	
		I	62232	217	247	230	
	1983>89	T	64078	266	234	460	
	1989>	T	65085	266	234	545	
		T	64202	230	232	440	
		I	63420	217	247	370	
		E	63229	231	232	300	

		<i>E</i>	63212	266	234	310	
	NISSAN - M.IBERICA						
	<i>Fecha Date</i>	<i>Eje Axle</i>	<i>Referencia Reference</i>	<i>Racor A Fitting</i>	<i>Racor B Fitting</i>	<i>LT</i>	
TERRANO							
<i>Terrano I</i>		<i>E</i>	62159	217	247	290	
<i>Terrano II</i>	1993>	<i>DI</i>	63323			335	
	93>	<i>DD</i>	63322			335	
	93>	<i>T</i>	64203	230		470	
<i>Terrano II</i>		<i>E</i>	62168	217		245	
<i>Terrano II</i>		<i>E</i>	62169	217		255	
TRADE							
<i>Trade 2.0</i>	1986>	<i>D</i>	65068	216	217	415	
		<i>T</i>	64142	216	218	470	
		<i>I</i>	63242	216	234	320	
<i>Trade 2.8</i>	>1986	<i>D</i>	65049	216	217	552	
		<i>T</i>	65082	217	218	530	
		<i>I</i>	63326	049	243	390	
<i>Trade 2.8</i>	1986>89	<i>D</i>	65067	216	217	440	
	1986>89	<i>T</i>	66012	217	218	625	
	1989>	<i>T</i>	65082	217	218	530	

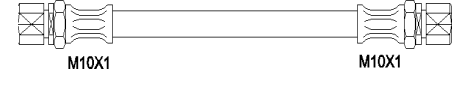
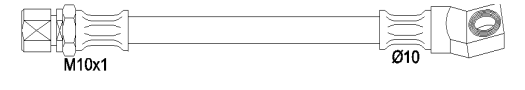
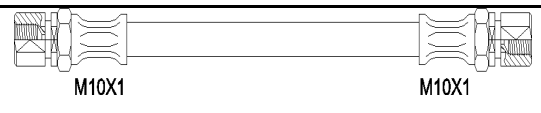
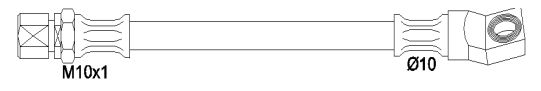
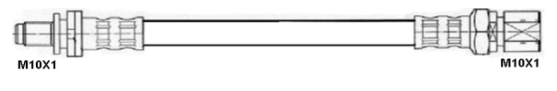
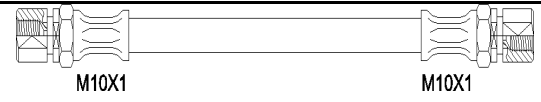
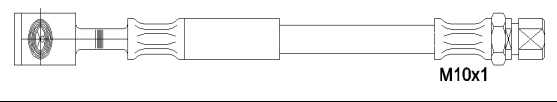
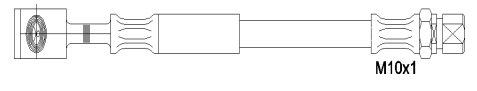
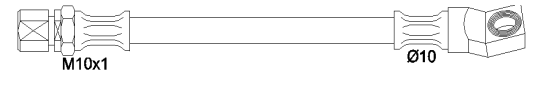
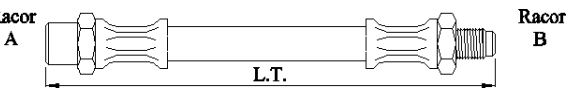
								
NISSAN - M.IBERICA								
Fecha Date	Eje Axle	Referencia Reference	Racor A Fitting	Racor B Fitting	LT			
TRADE								
Trade 3.0	91>	D	65079			395		
	91>	T	65082	217	218	530		
	91>	I	63242	216	234	320		
VANETTE								
Vanette (Todos modelos)	>1987	D	64085			460		
	1987>	D	64084			460		
		T	64086	266	234	417		
Cargo, Serena	1991>	D	63243	247	217	550		
		T	63244	230	232	300		
		T	63245	247	247	273		
		E	63246	266	234	430		
		E	63393	266	234	400		
M.I (CAMION)								
Nissan Camion B 45 (tambor ancho)		D	65520	143	145	510		
		T	65520	143	145	510		
Nissan CAMION B 45 (tambor estrecho)		D	64600	002	145	470		

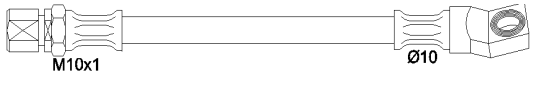
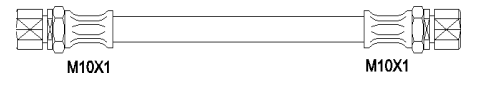
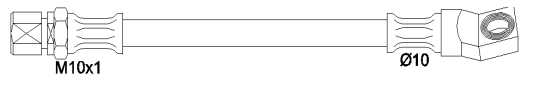

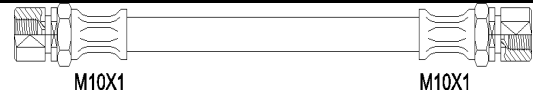
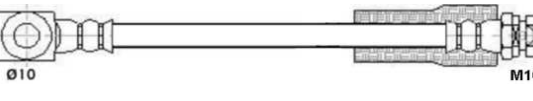
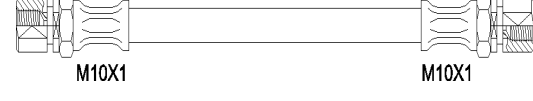
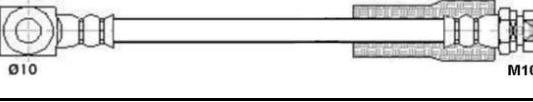
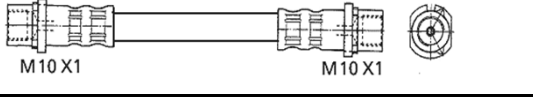
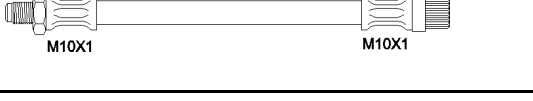
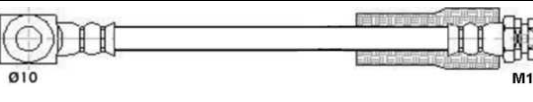
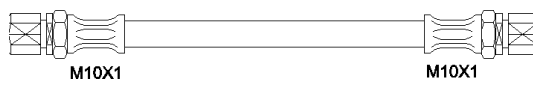
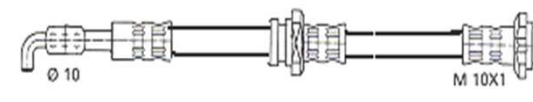
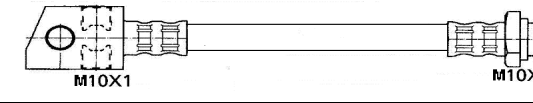
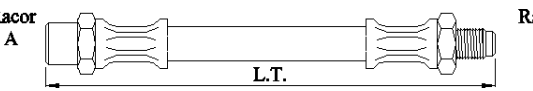
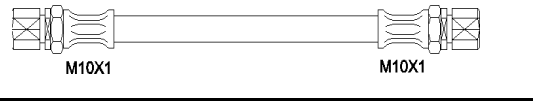
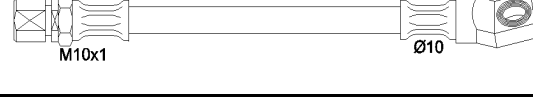
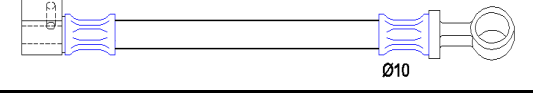
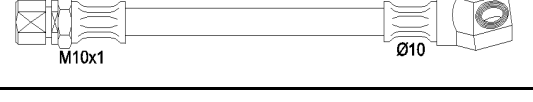

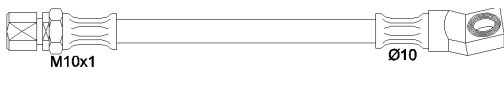
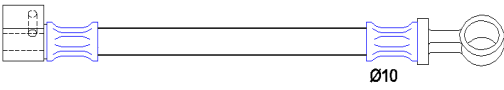
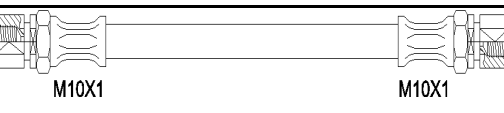
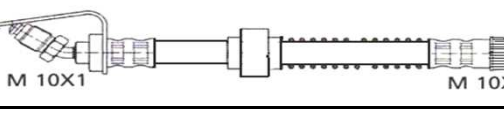
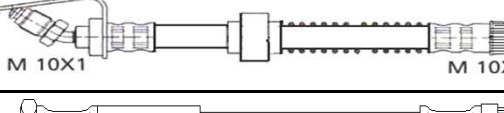
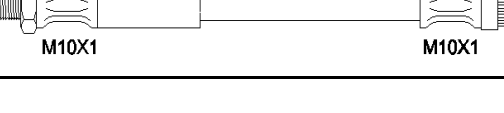
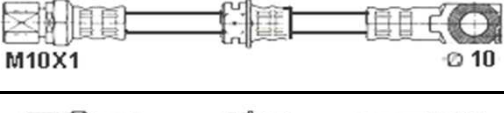
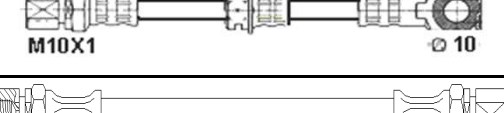
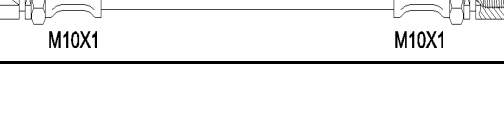
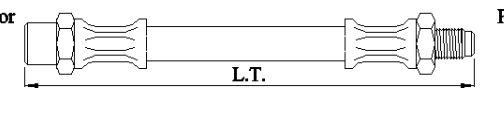
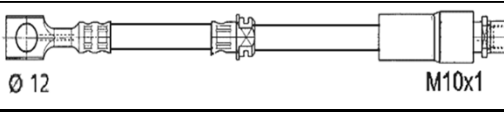
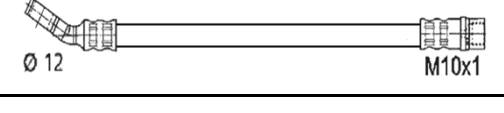
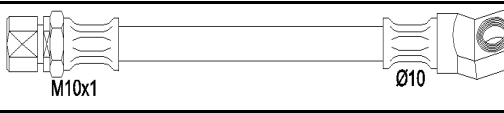
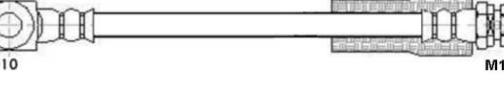

		T	64600	002	145	470	
NISSAN - M.IBERICA							
	Fecha Date	Eje Axle	Referencia Reference	Racor A Fitting	Racor B Fitting	LT	
M.I (CAMION)							
Nissan D 150, D 350, (camion ligero)		D	64003	143	145	468	
		T	64003	143	145	468	
M.I (CAMION)							
Nissan CAMION, E60, E70		D	65002	144	145	563	
Nissan CAMION, E60, E70		T	64001	144	145	468	
	Nissan F 100 F 108		D	64006	117	135	390
Nissan THAMES		D	66560	008	009	640	
Nissan THAMES		T	65100	008	008	500	
OPEL							
	Fecha Date	Eje Axle	Referencia Reference	Racor A Fitting	Racor B Fitting	LT	
AGILA							
Agila	1999>	D	64221			453	
		T	64222	232	232	300	
ASCONA							
Ascona	1974>79	D	64116	210	210	416	
	1979>81	D	64117	210	212	430	

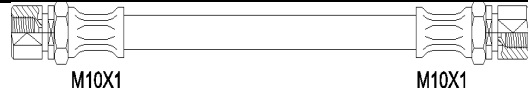
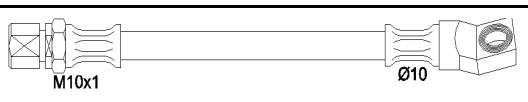
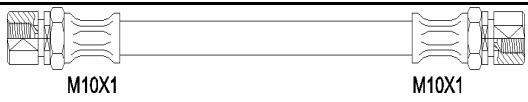
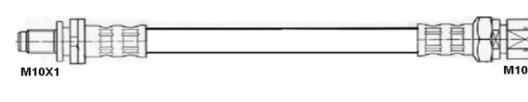
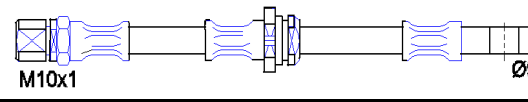
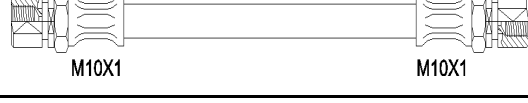
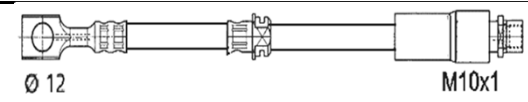
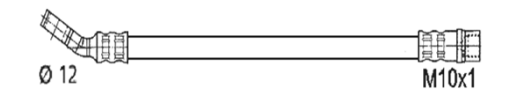
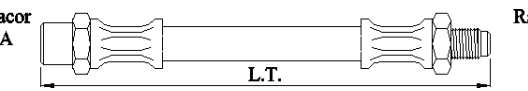
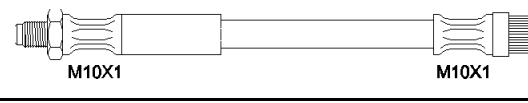
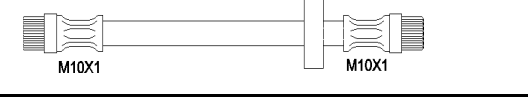
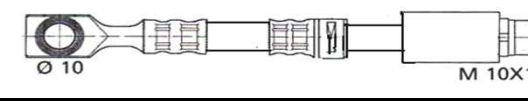
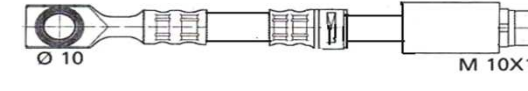

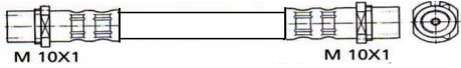
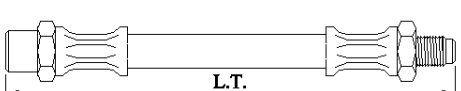
	1974>81	T	62082	210	210	275	
Ascona	1981>	D	63230	211	212	352	
		T	62037	211	211	235	
ASTRA (F)							
Astra	1991>98	D	63276	211	212	350	
Astra todos excepto Break, y Van	1991>	T	62197		211	242	
Break, Van	1991>	T	62037	211	211	235	
ASTRA (G)							
Astra II	98>	D	64198		211	410	
	98>	T	62212		211	215	
CALIBRA							
Calibra	1989>92	D	63230	211	212	352	
OPEL							
	Fecha Date	Eje Axle	Referencia Reference	Racor A Fitting	Racor B Fitting	LT	
CALIBRA							
Calibra	1989>92	T	62037	211	211	235	
CORSA							
Corsa	>1983	D	63071	210	212	316	
		T	62036	210	210	235	
Corsa	1983>	D	63072	211	212	316	

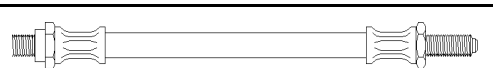
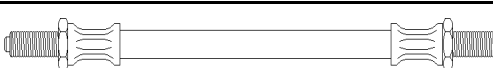
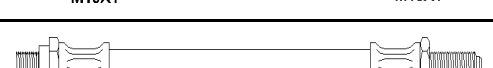
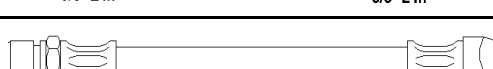
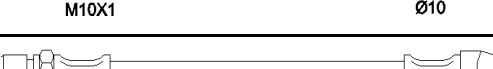
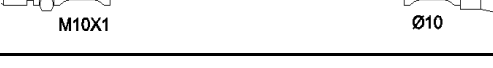

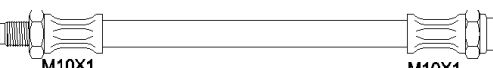
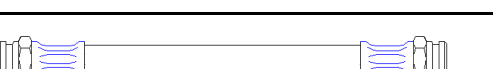
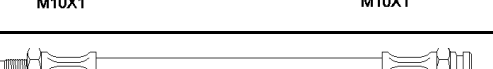
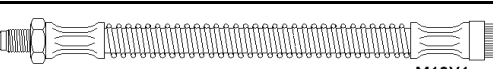
		T	62037	211	211	235	
Corsa B	1993>	D	63247		211	340	
		T	62037	211	211	235	
Corsa C Todos Modelos Excepto (1.4 16V, 1.8 16V 1.4 16V, 1.8 16V	2000>	D	63247		211	340	
		T	62220			218	
		T	62221	187	227	235	
CORSA COMBO							
Todos Modelos	1993>	D	63247		211	340	
	93>	T	64236	211	211	412	
FRONTERA							
Frontera	1991>	D	64223			450	
	91>	T	64224			480	
OPEL							
	Fecha Date	Eje Axle	Referencia Reference	Racor A Fitting	Racor B Fitting	LT	
KADETT							
Todos Modelos	>1976	D	63118	210	210	375	
Todos Modelos	1979>84	D	63119	210	212	400	
Todos Modelos	1984>85	DI	63248		212	350	
Todos Modelos	1984>85	DD	63230	211	212	352	
Todos Modelos	>1985	T	62036	210	210	235	

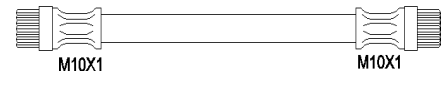
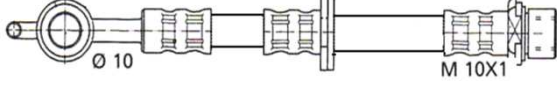
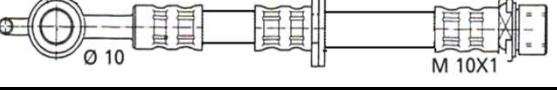
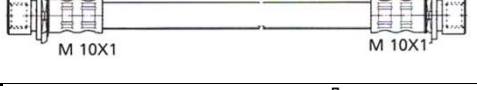
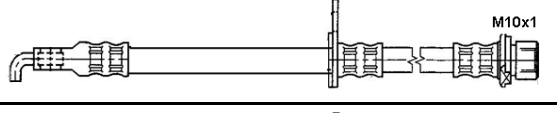
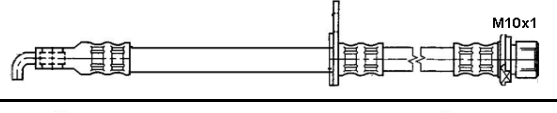
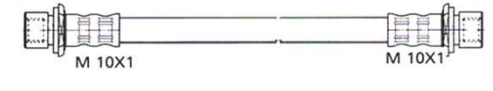
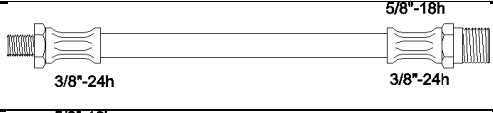
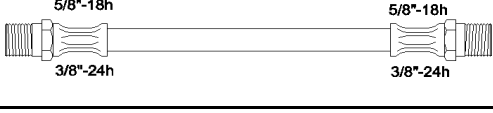
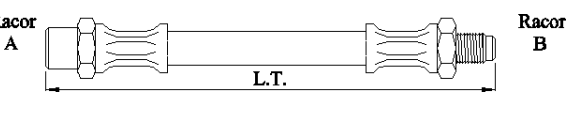
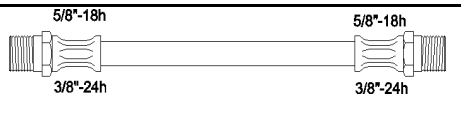
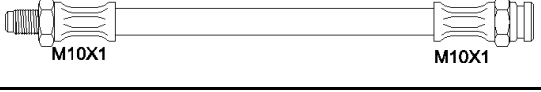
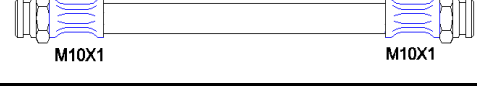
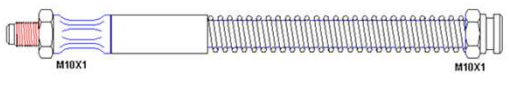

Todos Modelos	1985>91	DD	63230	211	212	352	
	85>	DI	63248		212	350	
	85>	T	62037	211	211	235	
MOVANO							
Movano	1999>	D	66018			606	
	99>	D	65117			562	
	99>	T	64121	187	227	465	
OMEGA							
Omega	1986>94	D	63327	211	212	430	
Omega B	1994>	D	63249	211	212	400	
Omega Todos modelos	1986>	T	62037	211	211	235	
OPEL							
							
	Fecha Date	Eje Axle	Referencia Reference	Racor A Fitting	Racor B Fitting	LT	
SIGNUN							
Todos Modelos	2003>	D	64240			425	
		T	63423			330	
TIGRA							
Todos Modelos	1988>94	D	63230	211	212	352	
Todos Modelos	1995>	D	63247		211	340	



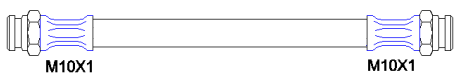
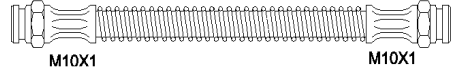
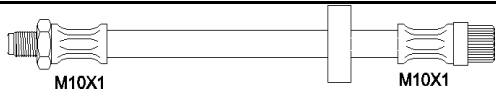
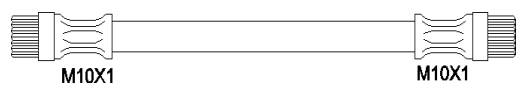
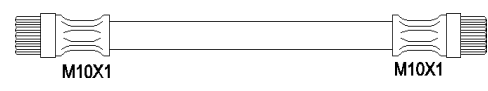
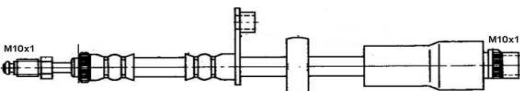
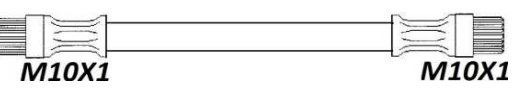
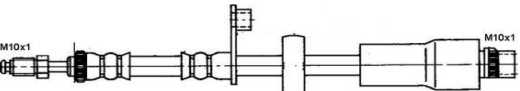
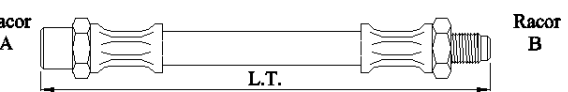
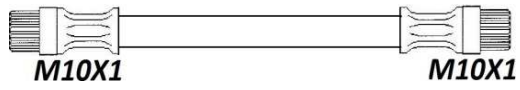

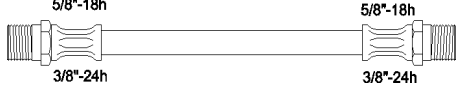
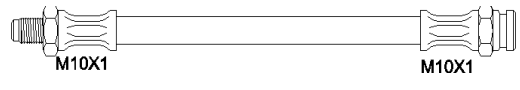
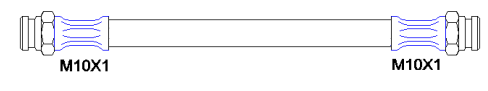

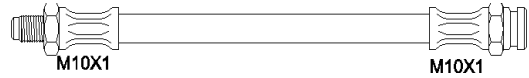
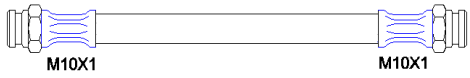
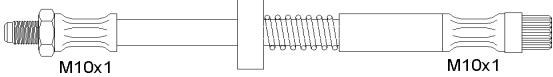
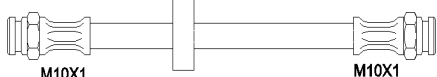
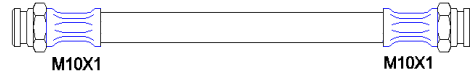
Todos Modelos		T	62037	211	211	235	
VECTRA A (1988>95)							
Todos Modelos	9/88>95	D	63230	211	212	352	
		T	62037	211	211	235	
		T	62197		211	242	
VECTRA B (1996>01)							
Todos Modelos	10/95>	D	64226			420	
	10/95>	T	62037	211	211	235	
VECTRA C (2002>)							
Todos Modelos	2002>	D	64240			425	
		T	63423			330	
OPEL							
							
	Fecha Date	Eje Axle	Referencia Reference	Racor A Fitting	Racor B Fitting	LT	
VIVARO							
Vivaro	2001>	D	64069	187	227	420	
		T	62057	227	227	243	
ZAFIRA							
ZAFIRA	1998>05	D	64225			420	
	2005>	D	64241	282	285	445	

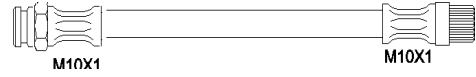
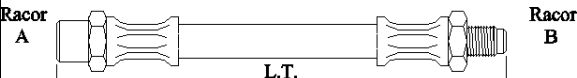
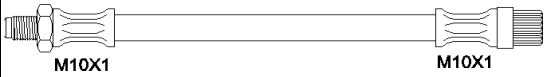
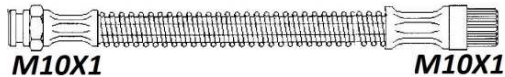
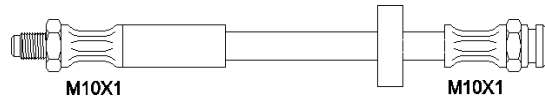
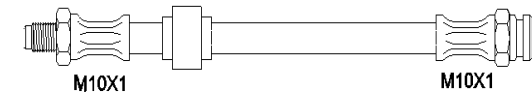
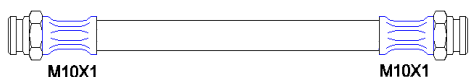

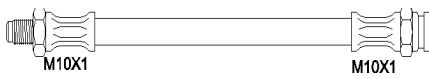

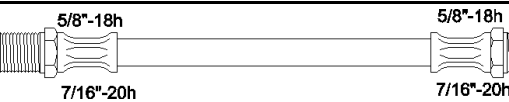
	1998>05	T	62222			245	
PEGASO							
	<i>Fecha Date</i>	<i>Eje Axle</i>	<i>Referencia Reference</i>	<i>Racor A Fitting</i>	<i>Racor B Fitting</i>	<i>LT</i>	
SAVA J4							
Sava J4		D	63143	219	219	372	
		I	63002	044	219	328	
Sava J4 1000		D	63144	220	220	372	
		I	63002	044	219	328	
Sava J4 1000 con freno de disco		DS	65043	216	222	528	
		DI	65044	216	222	580	
		I	63002	044	219	328	
PEUGEOT							
	<i>Fecha Date</i>	<i>Eje Axle</i>	<i>Referencia Reference</i>	<i>Racor A Fitting</i>	<i>Racor B Fitting</i>	<i>LT</i>	
104							
104	1975>	D	63068	187	191	375	
		TD	62038	191	191	278	
		TI	62062	187	191	294	
106							
Todos modelos (-ABS)	1991>	D	63217	187	227	350	
Todos modelos (+ABS)		D	63214	187	227	315	

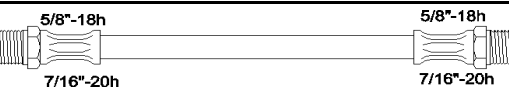

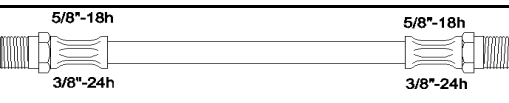
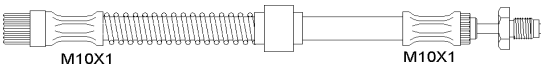
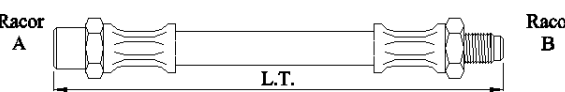
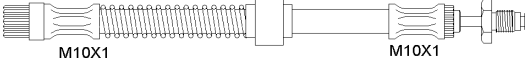
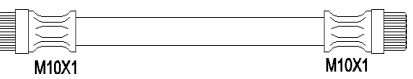
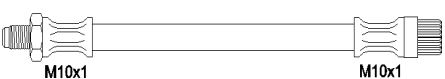
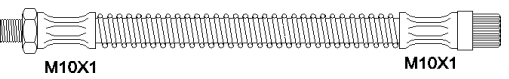
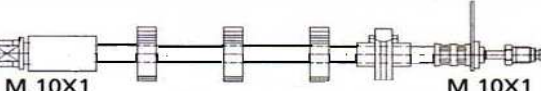
Todos modelos		T	62083	227	227	220	
107							
Todos modelos	2005>	DI	65136			510	
		DD	65135			510	
		T	62353			255	
1.0, 1.4 HDI	06/2005>	DI	65135			530	
1.0, 1.4 HDI	06/2005>	DD	65136			530	
1.0, 1.4 HDI		T	62355			255	
204							
Todos modelos	>1996	D	63109	138	182	373	
Todos modelos	1966>	D	63104	182	182	376	
PEUGEOT							
	Fecha Date	Eje Axle	Referencia Reference	Racor A Fitting	Racor B Fitting	LT	
204							
Todos modelos	>1975	T	62154	182	182	287	
Todos modelos	1975>77	D	63068	187	191	375	
		T	62038	191	191	278	
205							
Todos excepto Gti	1983>96	D	63073	187	191	355	
205 Gti	1984>	D	64059	187	191	440	

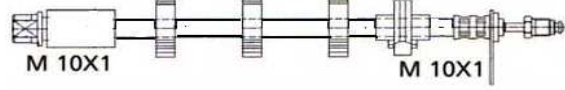
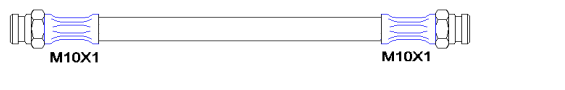
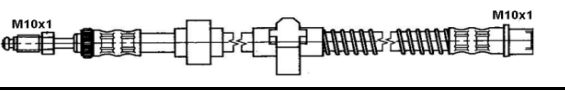
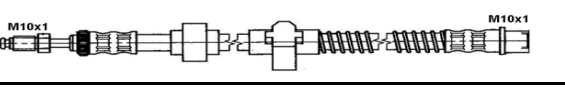
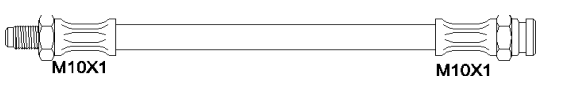
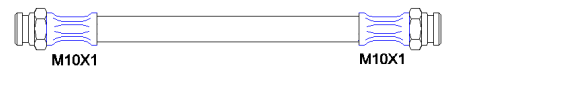
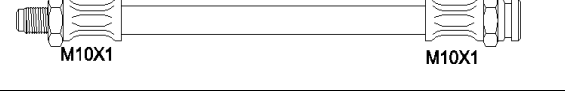
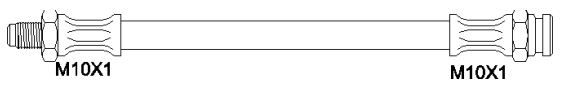
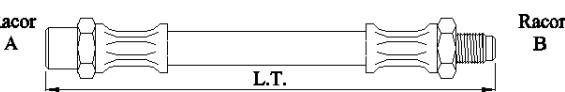
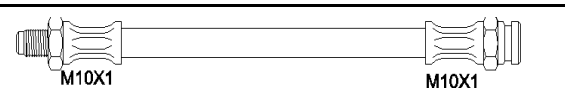
Todos modelos	83>96	TI	62038	191	191	278	
	83>96	TD	62039	191	191	278	
206							
Todos modelos	1998>	D	63194	187	227	330	
		TI	62052	227	227	268	
		TD	62098	227	227	222	
207							
Todos Modelos	06/2006>	D	65030			530	
Todos Modelos	06/2006>	T	62096	227	227	215	
208							
Todos Modelos	01/2012>	D	65030			530	
PEUGEOT							
	Fecha Date	Eje Axle	Referencia Reference	Racor A Fitting	Racor B Fitting	LT	
208							
Todos Modelos	01/2012>	T	62096	227	227	215	
304							
Todos modelos	>1975	D	63104	182	182	376	
		T	62154	182	182	287	
Todos modelos	1975>	D	63068	187	191	375	
		T	62038	191	191	278	

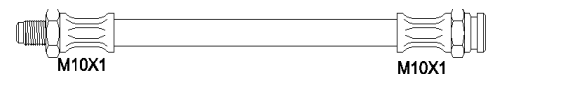

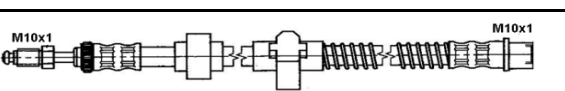
305								
Todos modelos	1982>90	D	63068	187	191	375		
		T	62022	191	191	237		
306								
306 todos	1993>	D	65069	187	227	550		
		TD	63092	191	191	263		
		TI	62054	191	191	213		
307								
		D	64242	187	227	445		
		T	62215	191	227	210		
PEUGEOT								
	<i>Fecha Date</i>	<i>Eje Axle</i>	<i>Referencia Reference</i>	<i>Racor A Fitting</i>	<i>Racor B Fitting</i>	<i>LT</i>		
308								
Todos Modelos	08/2000>	D	64242	187	227	445		
Todos Modelos	08/2000>	T	62118	191	227	210		
309								
Todos excepto GTI	1987>	D	63148	187	191	352		
GTI	1990>	D	64059	187	191	440		
Lado rueda		TD	62038	191	191	278		

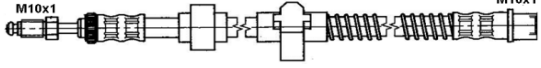
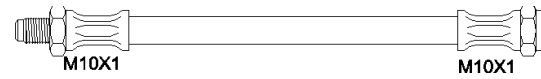
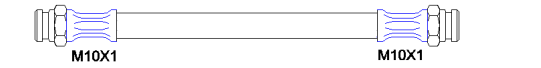
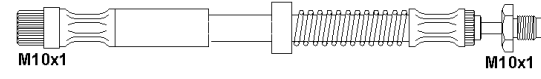
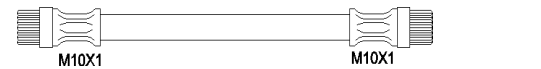

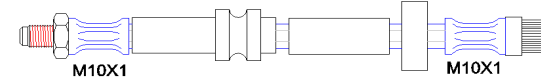
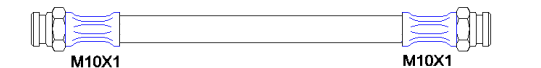
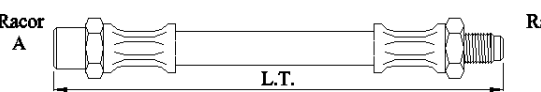
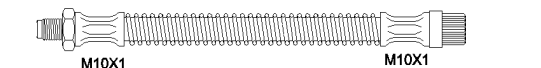
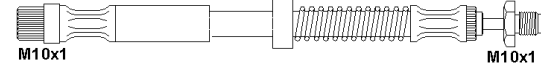
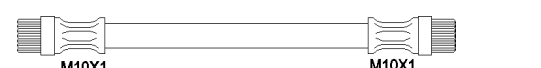
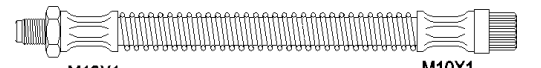
Lado pinza		TI	62051	187	191	257		
403								
Todos modelos		D	64170	043	055	412		
		T	64130	055	055	485		
404								
404	1960>65	D	63180	043	055	354		
		T	64130	055	055	485		
404	1966>	D	63107	138	182	373		
	1966>	T	63103	182	182	399		
405								
Todos excepto 4x4 Chasis > 8043879	1987>	D	65098	227	242	510		
PEUGEOT								
	Fecha Date	Eje Axle	Referencia Reference	Racor A Fitting	Racor B Fitting	LT		
405								
Todos excepto 4x4 Chasis 8043880 >	1987>	D	64082	227	242	457		
	Freno de tambor	1987>	T	62065	227	227	202	
	Freno de disco	1987>	T	62179	187	227	250	
	4X4	1987>	T	63214	187	227	315	
406								
Todos modelos	1995>	DI	64158			580		

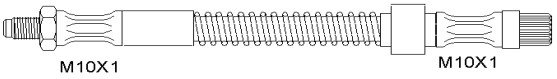
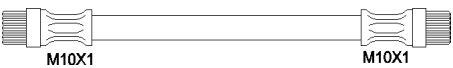
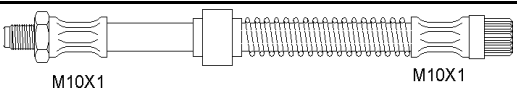
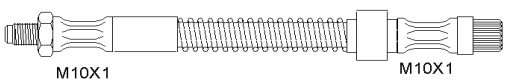
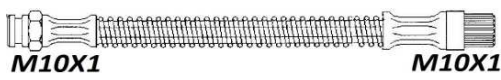
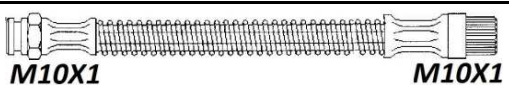
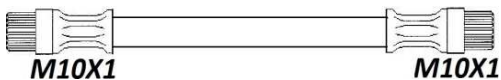
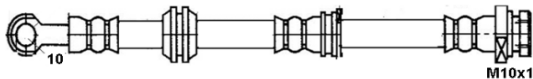
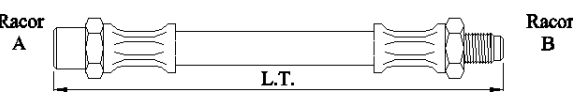
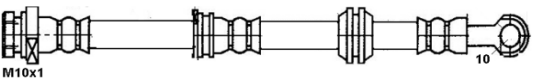
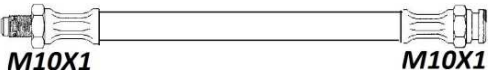
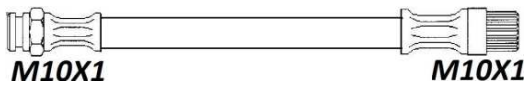
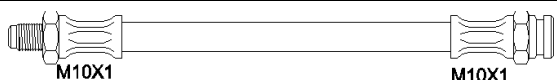

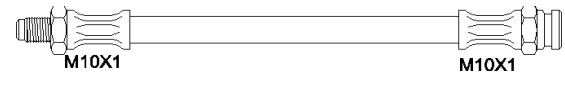
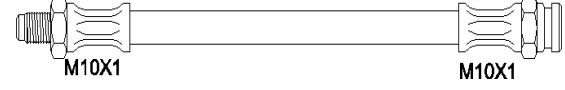
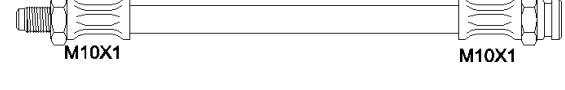
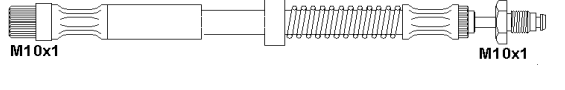

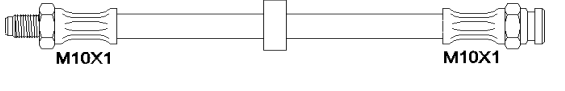
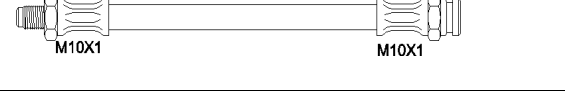
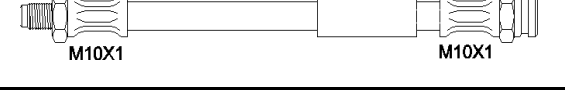
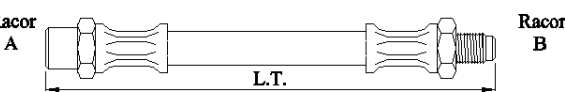
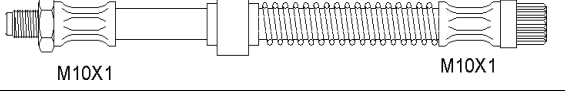
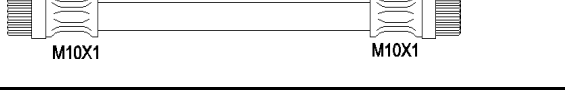
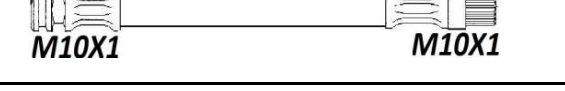
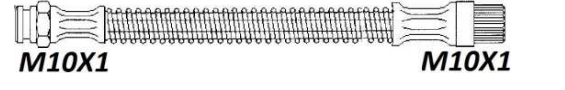
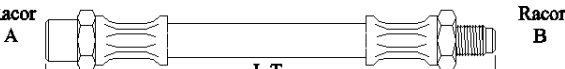
		DD	64157			580	
		T	63403	191	191	300	
407							
Todos Modelos	05/2004>	TI	66001			685	
Todos Modelos	05/2004>	TD	66002			685	
504							
Todos modelos	1975>86	D	64028	187	191	400	
Freno disco lado rueda		T	62022	191	191	237	
Freno disco lado chasis		T	63068	187	191	375	
505							
505 Berlina con ABS	1979>93	D	64059	187	191	440	
PEUGEOT							
	<i>Fecha Date</i>	<i>Eje Axle</i>	<i>Referencia Reference</i>	<i>Racor A Fitting</i>	<i>Racor B Fitting</i>	<i>LT</i>	
505							
505 Berlina sin ABS	1979>93	D	64028	187	191	400	
505 Berlina con ABS		T	62022	191	191	237	
505 Berlina sin ABS		T	63068	187	191	375	
Todos modelos		E	62066	186	186	230	
508							
Todos Modelos	11/2010>	TI	66001			685	

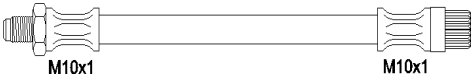
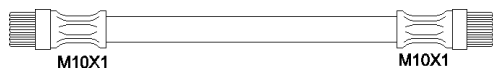
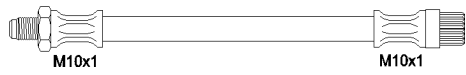
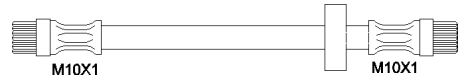
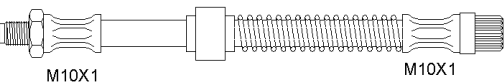
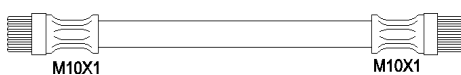
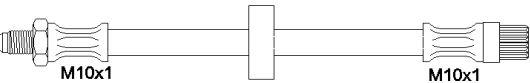
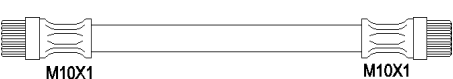
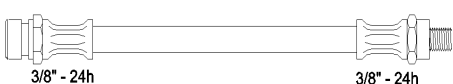

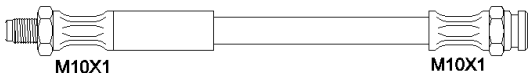
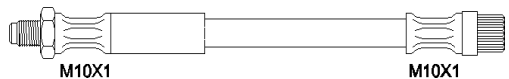
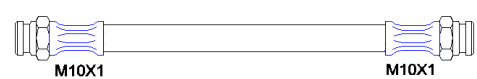
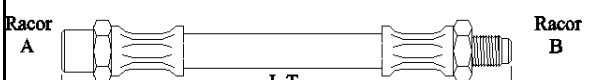
Todos Modelos		TD	66002			685		
604								
Todos modelos		1977>86	D	64028	187	191	400	
			T	62022	191	191	237	
605								
Todos modelos		1989>99	D	65061	227	242	565	
Lado chasis			T	62065	227	227	202	
Lado rueda			T	62078	187	227	235	
607								
Todos modelos		2000>	D	65119	187	227	595	
Lado chasis			T	61182	191	191	198	
PEUGEOT								
								
	<i>Fecha</i> Date	<i>Eje</i> Axle	<i>Referencia</i> Reference	<i>Racor</i> A Fitting	<i>Racor</i> B Fitting	<i>LT</i>		
607								
Lado rueda			T	62078	187	227	235	
806								
Todos modelos		1994>02	D	65075	242	227	540	
Lado chasis			T	62059	227	227	275	
Lado rueda			T	63314	187	227	330	
807								

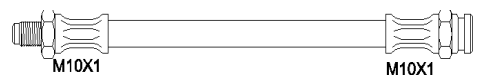
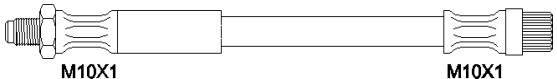

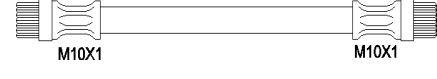
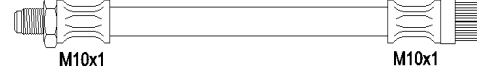
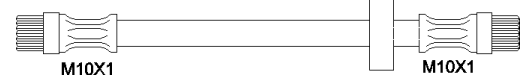
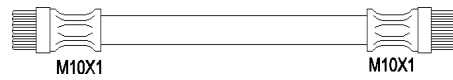
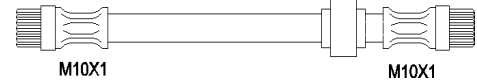

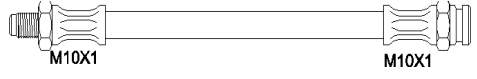
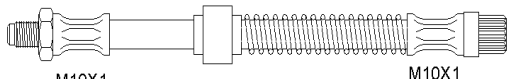
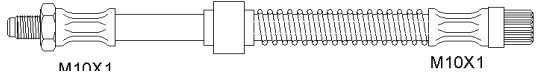
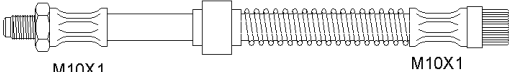
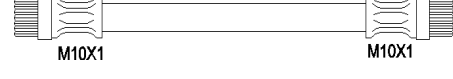
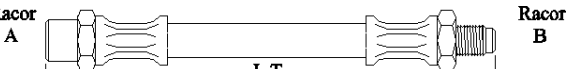

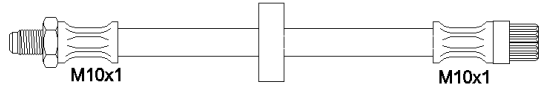
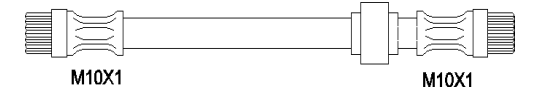

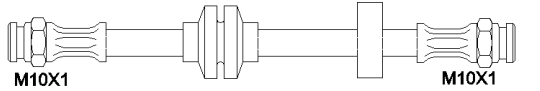
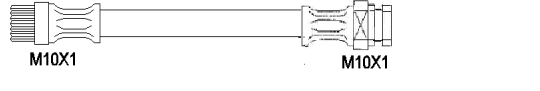
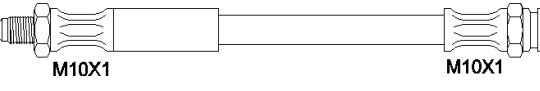
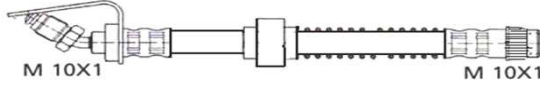
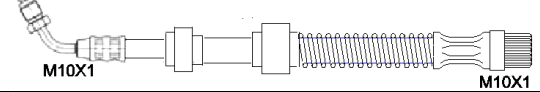
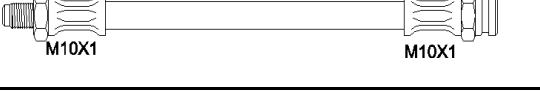
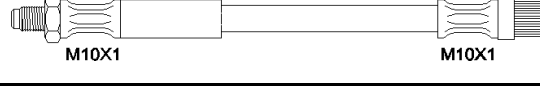
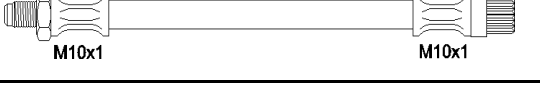
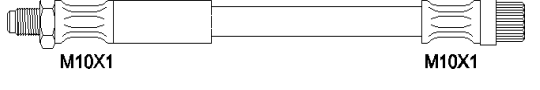
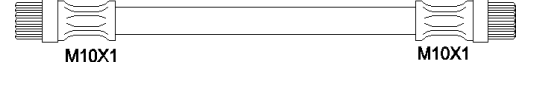
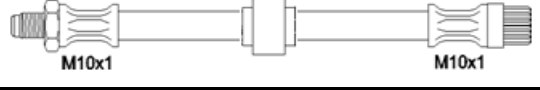
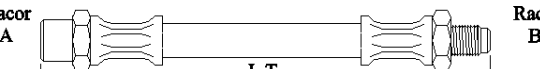
Todos modelos (-3.0 V6)	08/2002>	D	64049	187	227	485	
		T	62187	227	227	272	
1007							
1.4, 1.4 16V, 1.4HDI, 1.6 16V	04/2005>	D	64112	187	227	460	
1.6HDI 110	04/2007>	D	64046	187	227	490	
	04/2005>	T	62215	191	227	205	
		T	62118	191	227	210	
2008							
Todos Modelos	2013>	T	62096	227	227	215	
4007							
Todos Modelos	>11/2012	DD	66003			630	
	PEUGEOT						
	<i>Fecha Date</i>	<i>Eje Axle</i>	<i>Referencia Reference</i>	<i>Racor A Fitting</i>	<i>Racor B Fitting</i>	<i>LT</i>	
4007							
Todos Modelos	>11/2012	DI	66004			630	
Todos Modelos	>11/2012	T	63272	187	191	310	
5008							
Todos Modelos	09/2009>	T	62119	191	227	238	
BOXER							
Todos modelos	1994>	DI	63236	187	191	485	

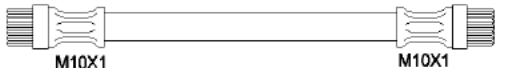
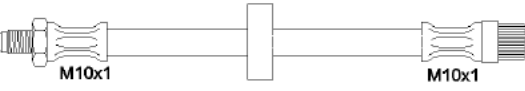
		<i>DS</i>	64081	187	191	457	
		<i>TI</i>	63084	187	191	347	
		<i>TD</i>	63199	187	191	360	
EXPERT							
<i>Todos modelos</i>		<i>D</i>	65075	242	227	540	
		<i>T</i>	62059	227	227	275	
J5							
<i>Todos modelos</i>		<i>D</i>	64098	187	191	465	
<i>Todos modelos</i>	>1994	<i>T</i>	62046	187	191	287	
<i>Todos modelos</i>	1994>	<i>T</i>	63078	187	191	380	
PEUGEOT							
							
	<i>Fecha Date</i>	<i>Eje Axle</i>	<i>Referencia Reference</i>	<i>Racor A Fitting</i>	<i>Racor B Fitting</i>	<i>LT</i>	
PARTNER							
<i>Todos modelos</i>	1997>	<i>D</i>	64112	187	227	460	
		<i>T</i>	62088	227	227	277	
<i>Todos Modelos</i>	2006>	<i>T</i>	62121	191	227	280	
RCZ							
<i>Todos Modelos</i>	2010>	<i>T</i>	62118	191	227	205	
RENAULT							
							

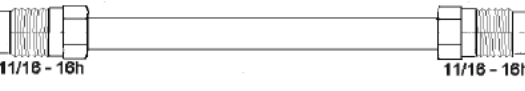

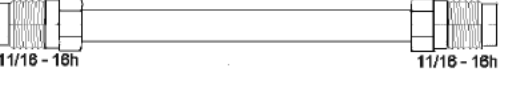
	Fecha Date	Eje Axle	Referencia Reference	Racor A Fitting	Racor B Fitting	LT	
CLIO							
Todos modelos (- ABS) excepto 1.8 16V, 2.0 Williams	1991>98	D	62067	187	227	268	
		T	62068	227	227	290	
Todos modelos (+ABS)	>1998	D	62179	187	227	250	
		T	62057	227	227	243	
CLIO II							
Todos modelos	1998>	D	63300	187	227	360	
		T	62065	227	227	202	
CLIO III							
Todos modelos	2005>	D	64143	187	227	485	
		T	62065	227	227	202	
DAUPHINE							
Todos modelos	1956>	D	62720	129	157	272	
		T	62172	129	157	230	
ESPACE							
Todos modelos	1985>91	D	64119	187	191	403	
	1991>96	D	64069	187	227	420	
Lado chasis	1985>	T	63179	191	191	370	
RENAULT							

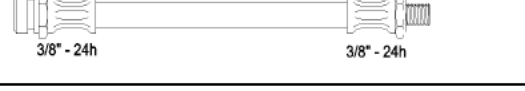
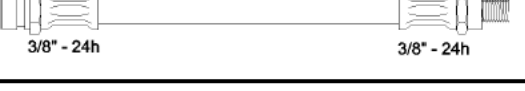
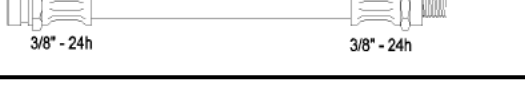

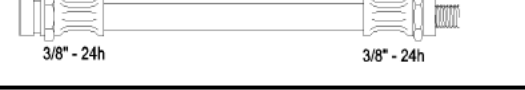
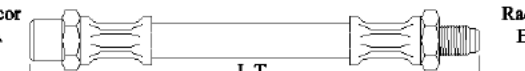

	Fecha Date	Eje Axle	Referencia Reference	Racor A Fitting	Racor B Fitting	LT	
SPACE							
Lado rueda	1985>	T	63162	187	191	290	
Todos modelos	1996>99	D	65137	187	227	520	
	1999>	D	65138	187	227	543	
Lado chasis		T	62065	227	227	202	
Lado rueda		T	62058	187	227	287	
EXPRESS							
Todos modelos	1986>	D	63194	187	227	330	
Todos modelos	03/86>	T	62052	227	227	268	
Suspensión reforzada	03/86>	T	63193	227	227	308	
FUEGO							
Todos modelos	1979>85	D	64064	187	191	410	
		T	63162	187	191	290	
KANGOO							
Todos modelos (-ABS)	1997>	D	63300	187	227	360	
Todos modelos (+ABS)	1997>	D	64244	187	227	453	
Lado rueda	1997>	TI	63300	187	227	360	
Lado chasis	1997>	TD	62083	227	227	220	
RENAULT							

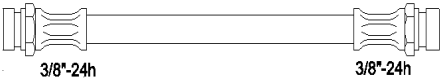
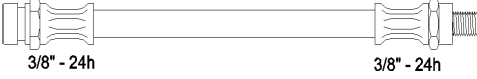
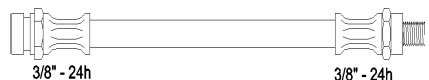
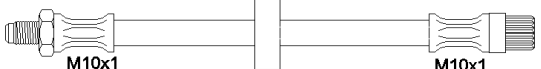
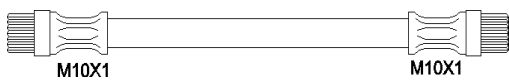
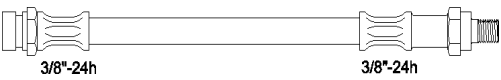
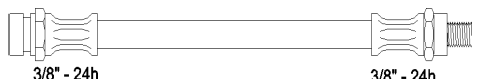

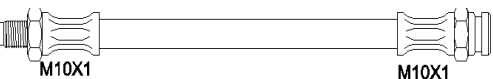
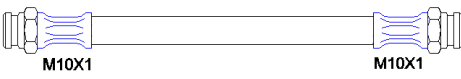
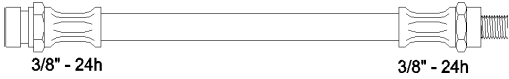
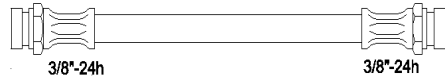
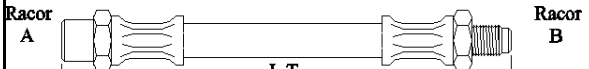

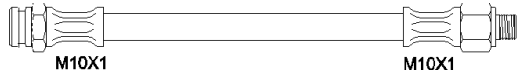
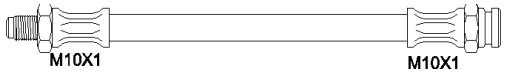
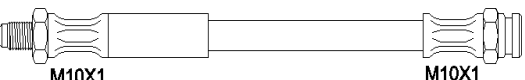
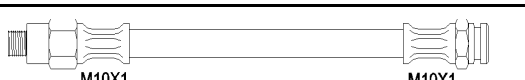
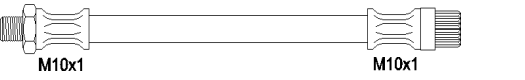
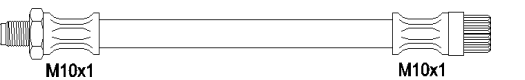
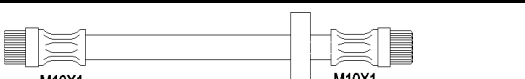
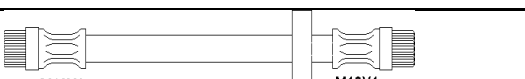
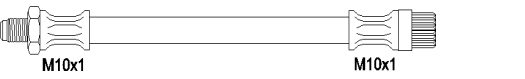

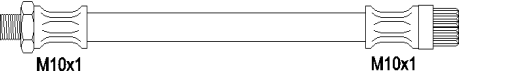

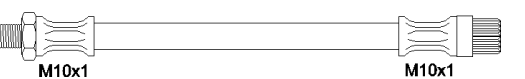
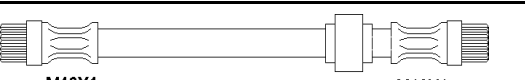
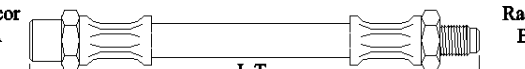

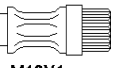
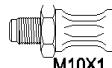
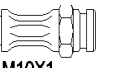
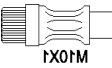
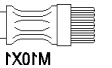
	Fecha Date	Eje Axle	Referencia Reference	Racor A Fitting	Racor B Fitting	LT	
LAGUNA I							
Todos modelos	1993>03/01	D	64143	187	227	485	
Lado chasis		T	63193	227	227	308	
Lado rueda		T	61198	187	227	185	
LAGUNA II							
Todos modelos	2001>	D	64243	191	191	410	
		T	62356	227		210	
MASTER							
Todos modelos	1980>	D	64123	187	191	500	
Todos modelos	1998>	D	65117			565	
Todos modelos	2000>	D	65139			507	
Lado rueda	1983>	T	63218	187	191	345	
	1998>	T	64121	187	227	465	
	1988>	T	63195	187	227	350	
MEGANE / SCENIC							
Todos modelos excepto Scenic RX4	1996>	D	64069	187	227	420	
		T	62068	227	227	290	
Scenic RX4	2000>	D	63397	187	227	430	
RENAULT							

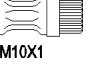
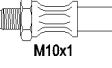
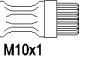

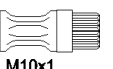
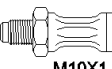
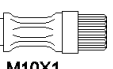
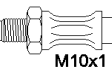

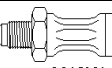

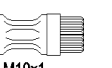
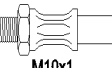
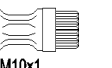
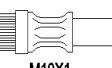
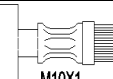
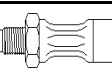
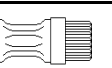
	Fecha Date	Eje Axle	Referencia Reference	Racor A Fitting	Racor B Fitting	LT	
MEGANE / SCENIC							
Lado chasis		TI	63398	227	227	452	
Lado rueda	00>	TD	63399	227	227	347	
MODUS							
Todos modelos	2004>	D	64143	187	227	485	
		T	62083	227	227	220	
4CV							
Todos modelos	1949<50	D	64010	003	003	420	
		T	62060	003	003	254	
Todos modelos	1950>53	D	63020	003	003	379	
		T	61030	003	003	184	
Todos modelos	1953>56	D	62700	027	129	290	
		T	62680	027	129	218	
Todos modelos	1956>61	D	63163	129	157	312	
		T	62740	129	157	222	
5 CV Dauphine							
Todos modelos	1956>59	D	62720	129	157	272	
		T	62730	129	157	252	
RENAULT							

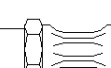
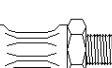

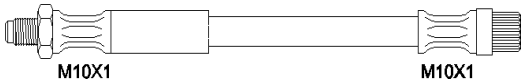
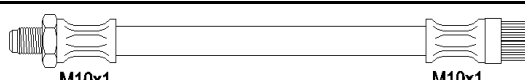

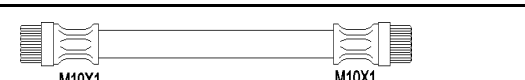
	Fecha Date	Eje Axle	Referencia Reference	Racor A Fitting	Racor B Fitting	LT	
R4							
Todos modelos	>1981	D	65830	062	129	504	
		T	62161	129	129	270	
Todos modelos	1981>	D	64005	129	130	430	
	1981>	TD	62161	129	129	270	
	1981>	TI	62730	129	157	252	
	1984>	T	63204	227	227	328	
R5 - 7							
Todos modelos	1972>	D	64005	129	130	430	
R5 - 7		T	62161	129	129	270	
Alpine		T	62730	129	157	252	
SUPER 5							
Todos modelos	1984>	D	63194	187	227	330	
		TD	63193	227	227	308	
		TI	62052	227	227	268	
R6							
Todos modelos	1971>81	D	65830	062	129	504	
	1981>	D	64005	129	130	430	
RENAULT							

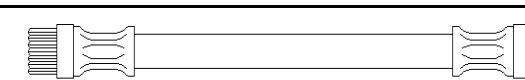
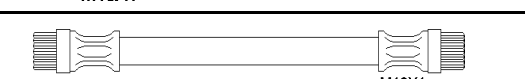

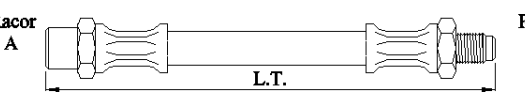
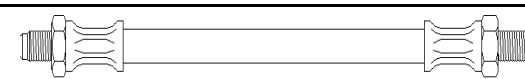
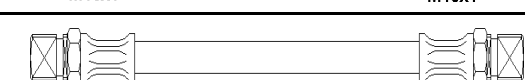
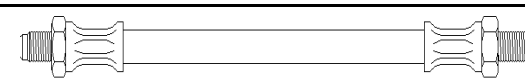
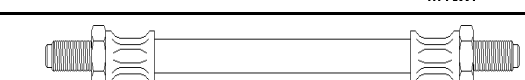
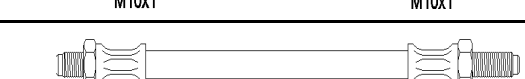

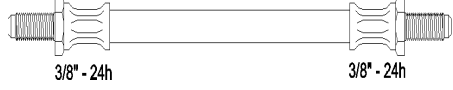
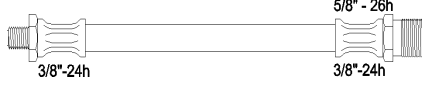
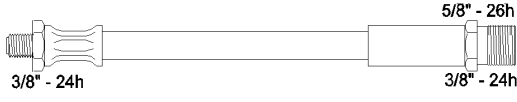
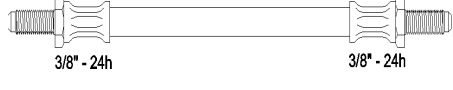
	Fecha Date	Eje Axle	Referencia Reference	Racor A Fitting	Racor B Fitting	LT	
R6							
Todos modelos	71>81	T	62161	129	129	270	
R8 - 10							
Todos modelos		D	63163	129	157	312	
R 8 - R10		T	62730	129	157	252	
R9 - 11							
Todos modelos	1981>90	D	63077	187	227	377	
		T	62045	227	227	270	
R12							
Todos modelos	1969>80	D	63296	129	136	340	
		T	63297	129	157	332	
R14							
Todos modelos	>1981	D	63045	190	191	325	
Todos modelos	1981>	D	63075	187	191	325	
Todos modelos	1981>	T	62025	191	191	262	
R16							
Todos modelos	1965>76	D	63112	129	157	364	
R 16		T	62330	129	129	210	
RENAULT							

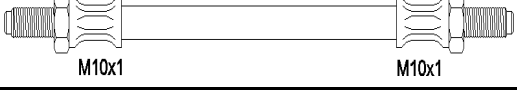
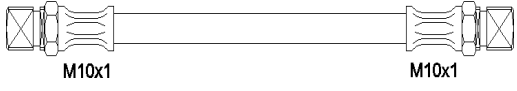
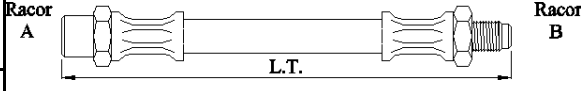
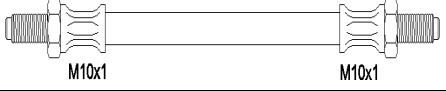
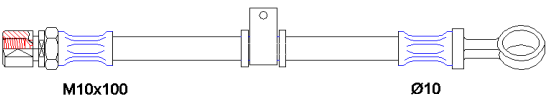
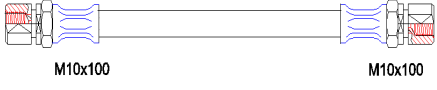
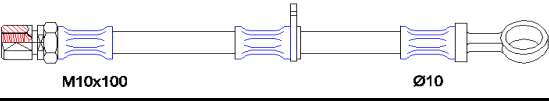

	Fecha Date	Eje Axle	Referencia Reference	Racor A Fitting	Racor B Fitting	LT	
R18							
Todos modelos con cierre sobre arandela	>81	D	63069	191	192	370	
Todos modelos con cierre sobre el cono		D	63046	187	191	370	
Todos modelos	1981>	D	64064	187	191	410	
Todos modelos		T	62026	190	191	297	
R19							
Todos modelos	1988>95	D	62058	187	227	287	
Todos modelos	1996>	D	63214	187	227	310	
Todos modelos (-ABS)	1988>	T	62059	227	227	275	
Todos modelos (+ABS)	1988>	T	62057	227	227	243	
R21							
Nevada	1986>	D	62067	187	227	268	
		T	62057	227	227	243	
R21							
Todos modelos exc.diesel	1986>	D	62067	187	227	268	
		T	63193	227	227	308	
Todos modelos diesel	1986>	D	63195	187	227	350	
		T	63193	227	227	308	
RENAULT							

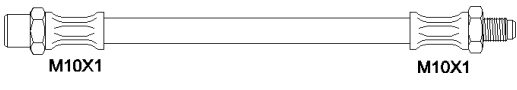
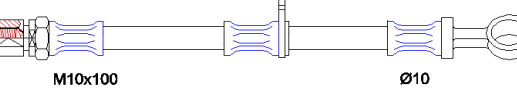
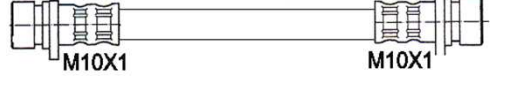
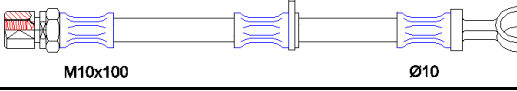
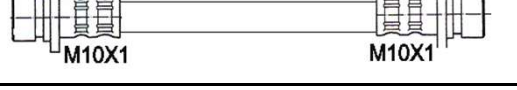
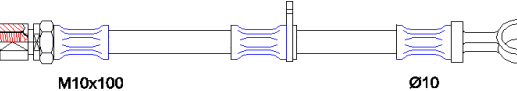
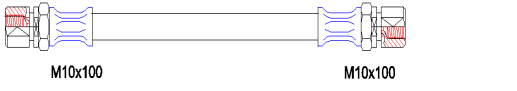
	Fecha Date	Eje Axle	Referencia Reference	Racor A Fitting	Racor B Fitting	LT	
R25							
Todos modelos	03/84> 09/84	D	64121	187	227	465	 M10X1  M10X1
Todos modelos	10/84>	D	64201	187	191	430	 M10X1  M10X1
Todos modelos lado chasis		T	62052	227	227	268	 1X01M  1X01M
Todos modelos (-ABS) lado rueda		T	62053	190	227	292	 M10X1  M10X1
Todos modelos (+ABS) lado rueda		T	61198	187	227	185	 M10x1  M10x1
SAFRANE							
Todos modelos	1992>	D	63205	187	227	325	 M10x1  M10x1
Todos modelos (+ABS)		T	64069	187	227	420	 M10X1  M10X1
Todos modelos 3.0 V6 4X4		T	63194	187	227	330	 M10x1   M10x1
SPORT / SPIDER							
Exterior	1996>	D	64069	187	227	420	 M10X1  M10X1
Interior	1996>	D	62058	187	227	287	 M10x1  M10x1
Exterior		T	62179	187	227	250	 M10x1  M10x1
Interior		T	62057	227	227	243	 M10X1  M10X1
TRAFIC							
Serie P	1980>	D	63195	187	227	350	 M10X1  M10X1
	1980>	T	64121	187	227	465	 M10X1  M10X1
RENAULT							 Racor A  Racor B

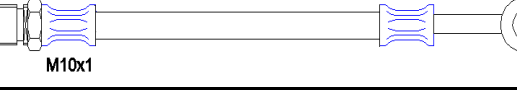
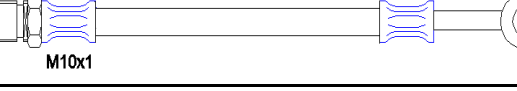
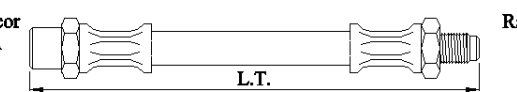
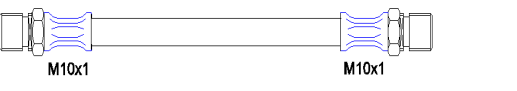
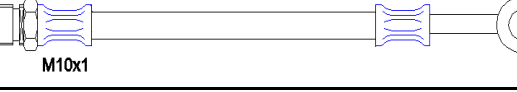
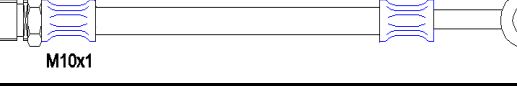
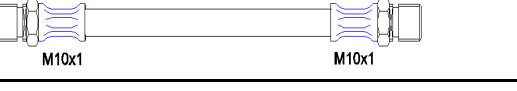
	Fecha Date	Eje Axle	Referencia Reference	Racor A Fitting	Racor B Fitting	LT	
TRAFIC							
Serie T	1980>	D	63195	187	227	350	
	1980>	T	64122	187	227	410	
Todos	2001>	D	64122	187	227	410	
		T	62083	227	227	220	
TWINGO							
Todos modelos	1993>	D	62067	187	227	268	
	1993>96	T	62045	227	227	270	
	1996>	T	62065	227	227	202	
	2000>	T	62057	227	227	243	
ROVER - AUTHI							
Fecha Date	Eje Axle	Referencia Reference	Racor A Fitting	Racor B Fitting	LT		
MAESTRO							
Todos modelos	>1990	D	63250	187	223	325	
	>90	T	62180	184	184	250	
METRO							
Todos modelos	>1990	D	63250	187	223	325	
	>90	TD	62181	223	223	205	
	>90	TI	62182	187	223	205	

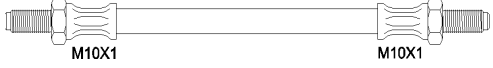
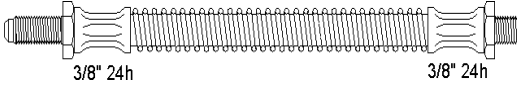
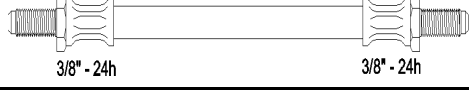
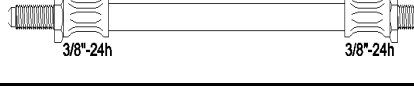
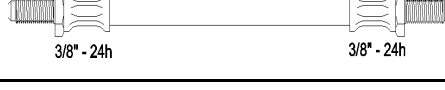
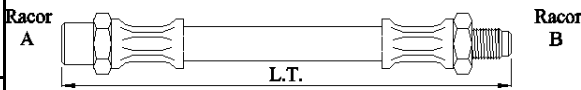

ROVER MINI								
850, 1000L	1969>	D	63293	119	120	325		
		T	62420	117	117	202		
		E	61660	119	120	192		
1275	1969>	D	62164	119	120	293		
		T	62420	117	117	202		
		E	61660	119	120	192		
MONTEGO								
Todos modelos	1984>	D	63250	187	223	325		
Berlina	11/84>	T	63284	223	223	318		
Break	11/84>	T	62202	184	184	283		
ROVER - AUTHI								
	<i>Fecha Date</i>	<i>Eje Axle</i>	<i>Referencia Reference</i>	<i>Racor A Fitting</i>	<i>Racor B Fitting</i>	<i>LT</i>		
ROVER 100								
Todos modelos	95>	T	62181	223	223	205		
ROVER 200								
Todos modelos 213, 216 (84>90)	1984>90	D	64229			485		
		T	62223			240		
Todos modelos 214,216,218D,218TD	1990>95	D	65120			505		
Todos modelos 214,216,218D,218TD (-ABS)		T	62223			240		

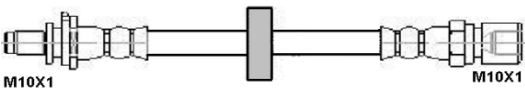
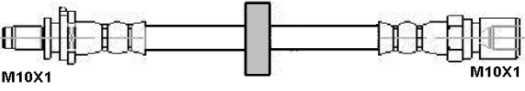
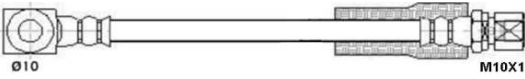
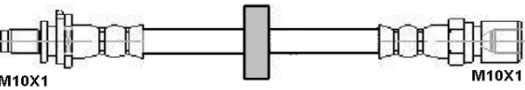
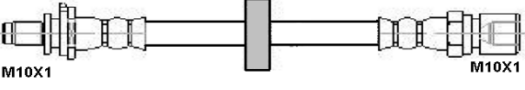
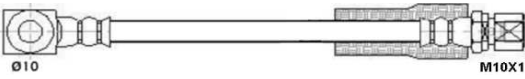
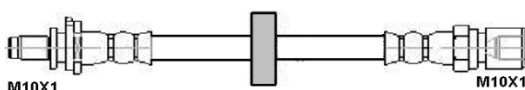
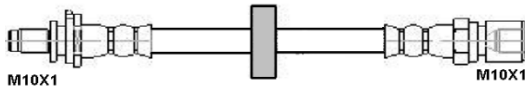
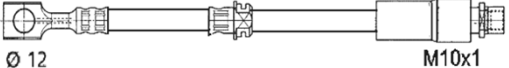

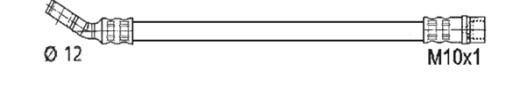
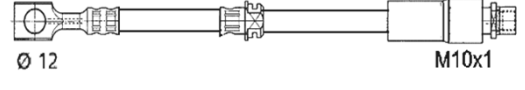
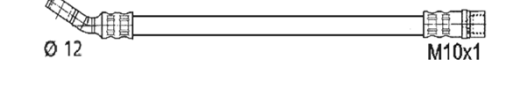
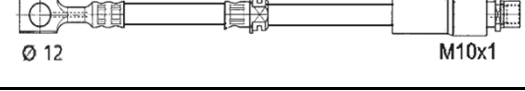
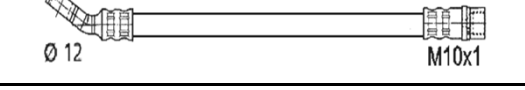
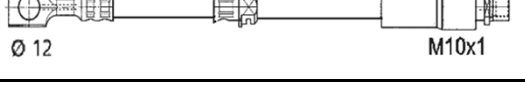
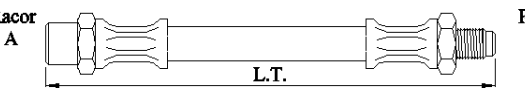
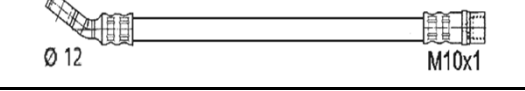
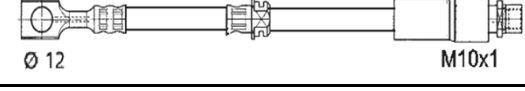
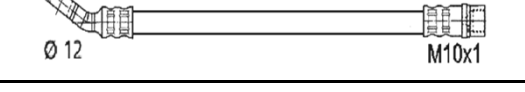
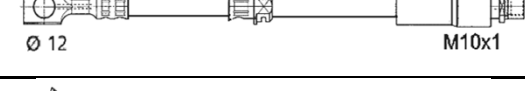
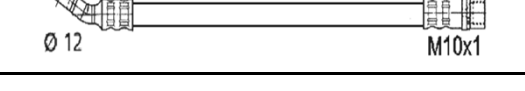
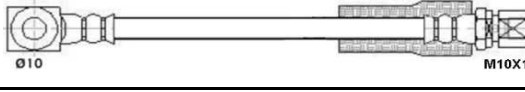
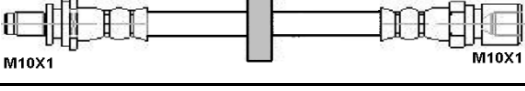
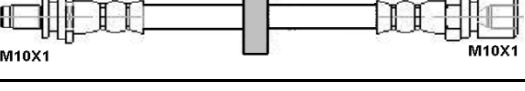
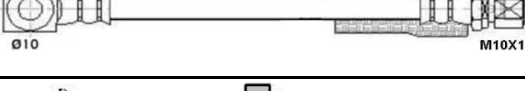
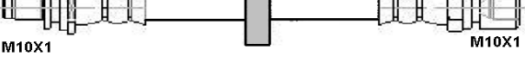
Todos modelos 214,216,218D,218TD (+ABS)		T	65122			486	
Todos modelos 211,214,216,218, 220D, 220SDI	1996>00	D	65121			500	
		T	62224			290	
Todos modelos 25 1.4, 1.6, 1.8, 2.0D	1999>	D	65121			500	
	99>	T	62224			290	
ROVER 400							
Todos modelos 414, 416, 418D, 418TD, 420	1990>95	D	65120			505	
Todos modelos 414, 416, 418D, 418TD, 420 (-ABS)	90>95	T	62223			240	
Todos modelos 414, 416, 418D, 418TD, 420 (+ABS)		T	65122			486	
Todos modelos 414, 416, 420, 420D	1995>00	DD	65124			685	
		DI	65123			685	
ROVER - AUTHI							
	Fecha Date	Eje Axle	Referencia Reference	Racor A Fitting	Racor B Fitting	LT	
ROVER 400							
Todos modelos 414, 416, 420, 420D	1995>00	T	62225			248	
Todos modelos 45 1.4l, 1.6l, 1.8l, 2.0l, 2.0 DTI	2000>	DD	65124			685	
		DI	65123			685	
		T	62225			248	
ROVER 900							
Todos modelos	80>93	D	63250	187	223	325	

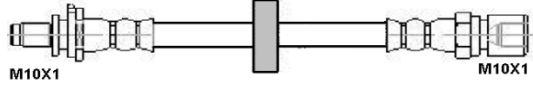
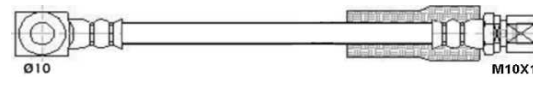
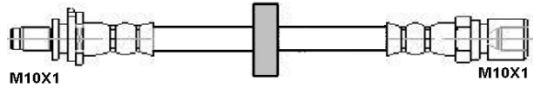
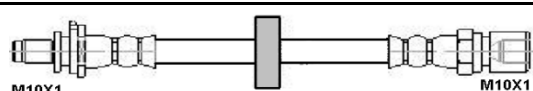
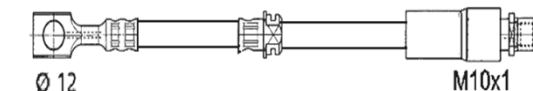
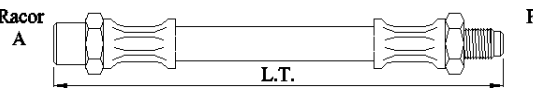
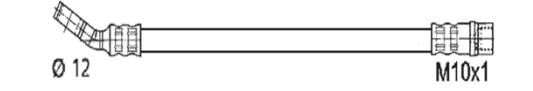
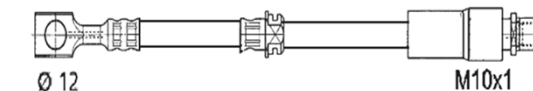
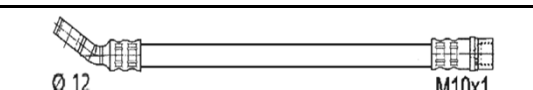
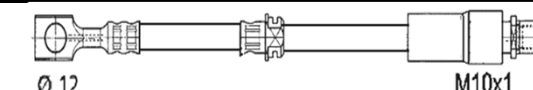
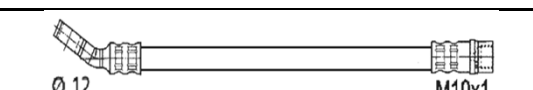
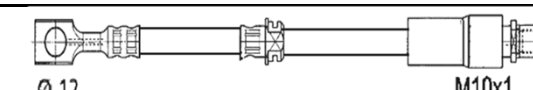
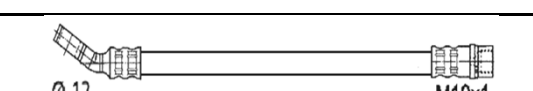
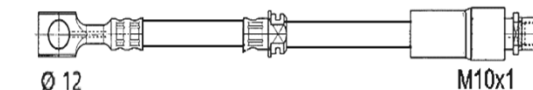
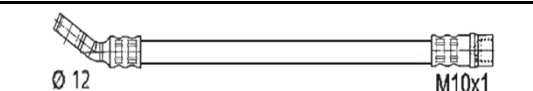
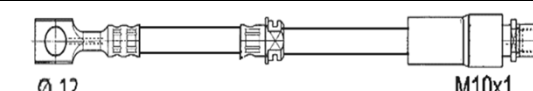

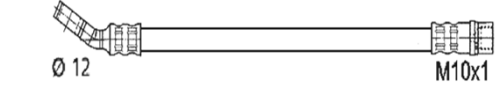
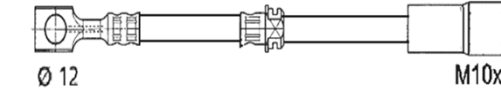
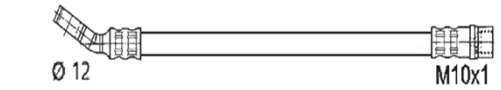
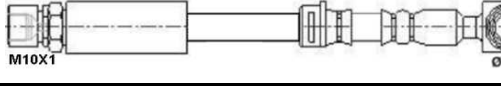
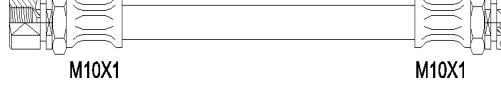
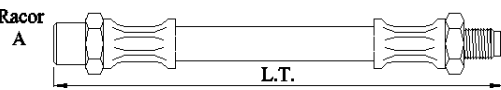
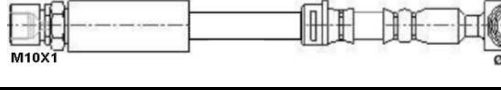
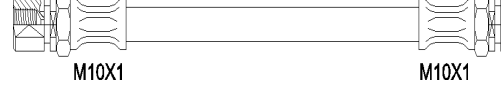
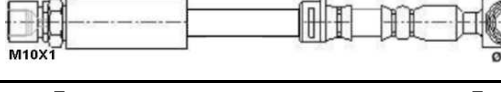
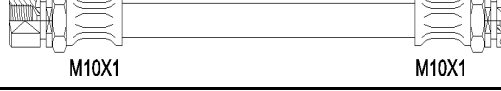
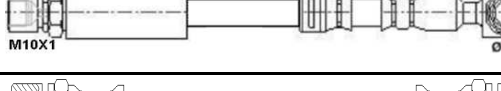
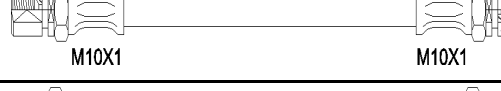
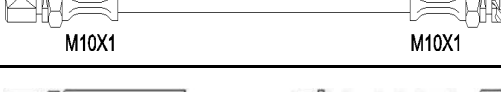
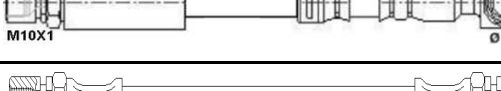
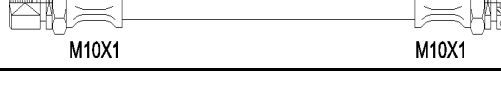
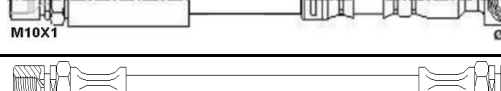
	80>93	T	63284	223	223	318		
VICTORIA								
1100, 1300	1969>	D	63285	117	119	296		
		T	62350	117	117	265		
		E	61570	117	119	188		
		I	62360	117	117	240		
SAAB								
	Fecha Date	Eje Axle	Referencia Reference	Racor A Fitting	Racor B Fitting	LT		
9-3 YS3D								
2.0i, 2.0 SE Turbo, 2.0 Turbo, 2.3i	02/98>09/02	D	63247			211	340	
		TI	62197	211	237	242		
		TD	62197	211	237	242		
2.2 TiD	02/98>09/02	D	63247			211	340	
		TI	62197	211	237	242		
		TD	62197	237	211	242		
2.3, 2.3 Turbo	09/99>01/02	D	63247			211	340	
		TI	62197	211	237	242		
		TD	62197	211	237	242		
9-3 YS3F								
1.8t, 2.0t	09/02>12/07	D	64240	282	285	425		

		T	63423	049	282	330	
1.8	01/07>	D	64240	282	285	425	
		T	63423	049	282	330	
1.8i	01/04>	D	64240	282	285	425	
		T	63423	049	282	330	
1.9 TiD	09/04>	D	64240	282	285	425	
SAAB							
	<i>Fecha Date</i>	<i>Eje Axle</i>	<i>Referencia Reference</i>	<i>Racor A Fitting</i>	<i>Racor B Fitting</i>	<i>LT</i>	
9-3 YS3F							
1.9 TiD	09/04>	T	63423	049	282	330	
2.0 T, 2.2 TiD	09/02>	D	64240	282	285	425	
		T	63423	049	282	330	
2.8 Turbo V6	03/05>	D	64240	282	285	425	
		T	63423	049	282	330	
9-3 Cabriolet YS3D							
2.0i, 2.0 SE Turbo, 2.0Turbo, 2.3i	02/98>08/03	D	63247			340	
		TI	62197	211	237	242	
		TD	62197	211	237	242	
2.3	08/99>01/02	D	63247			340	
		TI	62197	211	237	242	

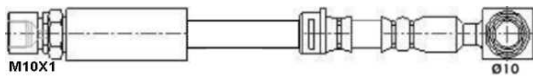
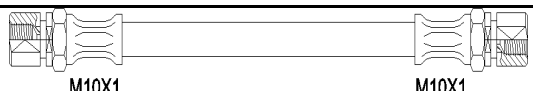
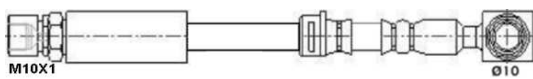
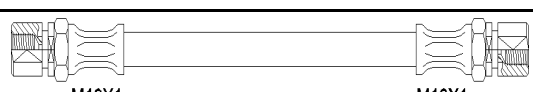
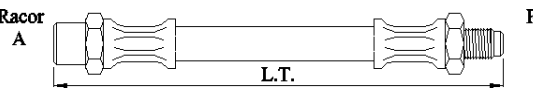
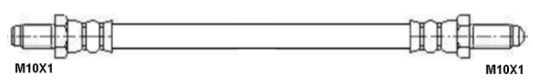
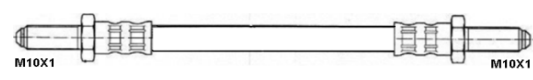
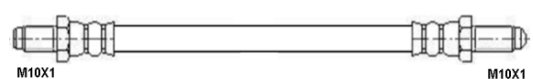
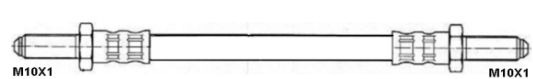

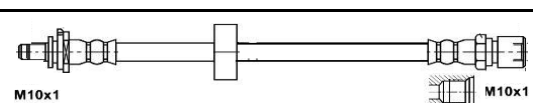
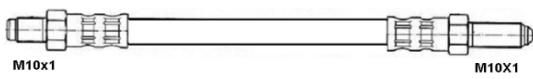
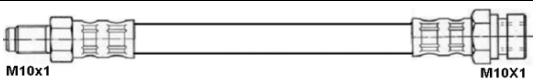
		TD	62197	211	237	242		
2,3 Turbo	09/99>08/03	D	63247			211	340	
		TI	62197	211	237	242		
		TD	62197	211	237	242		
9-3 Convertible YS3F								
1.8t, 2.0t	08/03>	D	64240	282	285	425		
9-3 Convertible YS3F		SAAB						
		<i>Fecha Date</i>	<i>Eje Axle</i>	<i>Referencia Reference</i>	<i>Racor A Fitting</i>	<i>Racor B Fitting</i>	<i>LT</i>	
9-3 Convertible YS3F								
1.8t, 2.0t	08/03>	T	63423	049	282	330		
1.8t BP, 2.0t BP	01/07>	D	64240	282	285	425		
		T	63423	049	282	330		
1.9 TiD	01/06>	D	64240	282	285	425		
		T	63423	049	282	330		
2.8 Turbo V6	02/06>	D	64240	282	285	425		
		T	63423	049	282	330		
9-3 ESTATE YS3F								
1.8i, 1.8t, 1.9 TiD, 2.0t, 2.8 Turbo V6	03/05>	D	64240	282	285	425		
		T	63423	049	282	330		
1.8t BP, 2.0t BP	01/07>	D	64240	282	285	425		

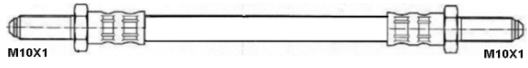
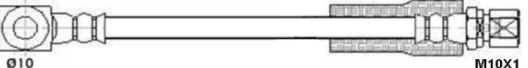
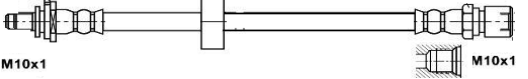
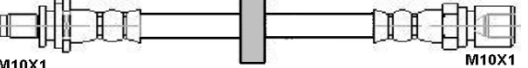
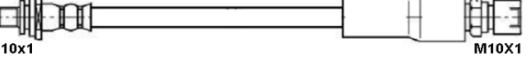
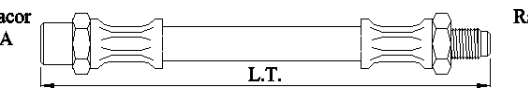
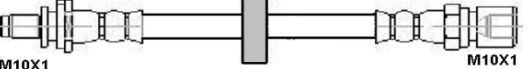
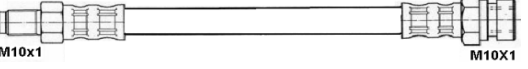
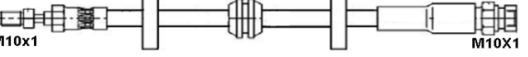
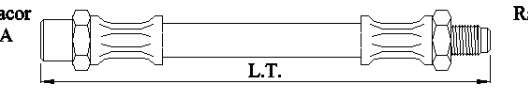
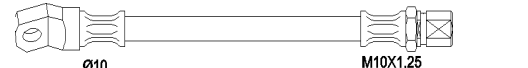
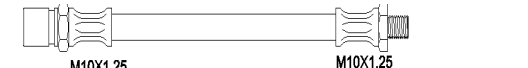
		T	63423	049	282	330	
2.0 T BP	02/09>	D	64240	282	285	425	
		T	63423	049	282	330	
9-5 YS3E							
1.9 TiD, 2.0t BP	01/06>	D	64156			445	
		T	62037	211	211	235	
SAAB							
	<i>Fecha Date</i>	<i>Eje Axle</i>	<i>Referencia Reference</i>	<i>Racor A Fitting</i>	<i>Racor B Fitting</i>	<i>LT</i>	
9-5 YS3E							
2.0	07/00>07/01	D	64156			445	
		T	62037	211	211	235	
2.0t, 2.3t	11/98>	D	64156			445	
		T	62037	211	211	235	
2.2TiD	03/02>	D	64156			445	
		T	62037	211	211	235	
2.3	06/03>08/05	T	62037	211	211	235	
2.3t BP	11/06>	D	64156			445	
		T	62037	211	211	235	
2.3 Turbo	10/99>	D	64156			445	
		T	62037	211	211	235	



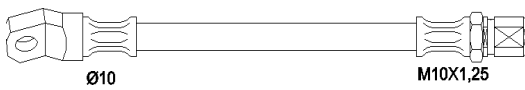
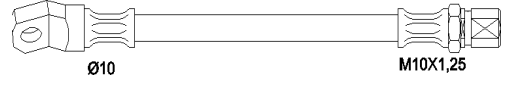
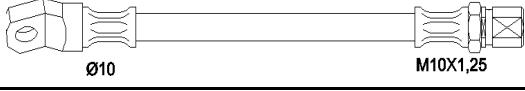
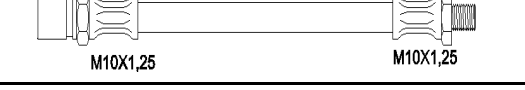
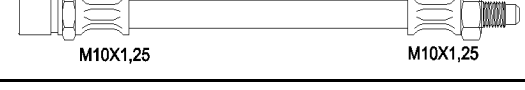
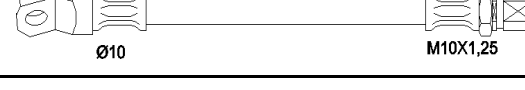
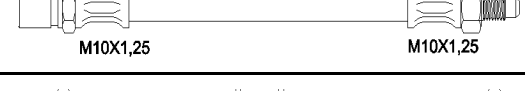
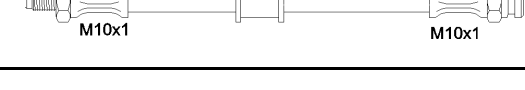
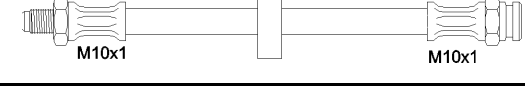
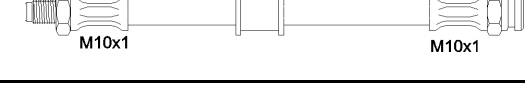
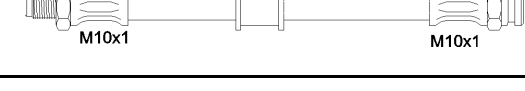
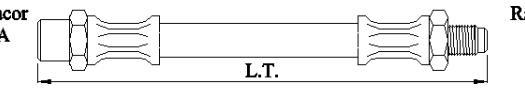
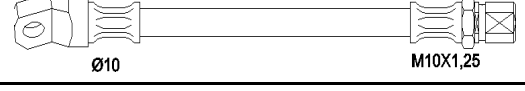
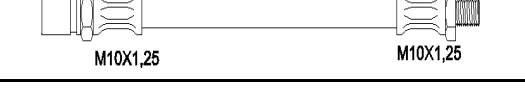
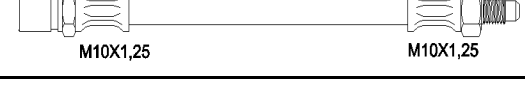

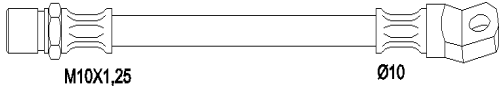
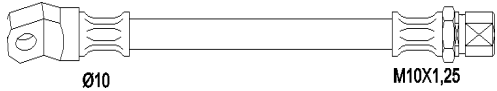
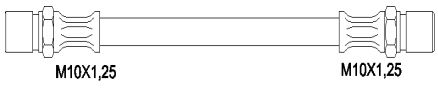
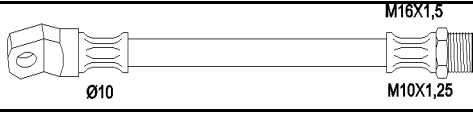
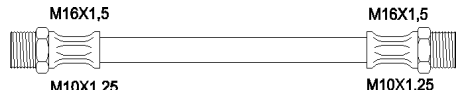
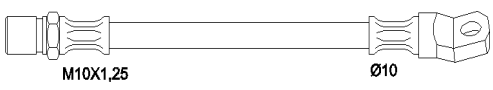
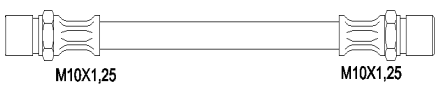
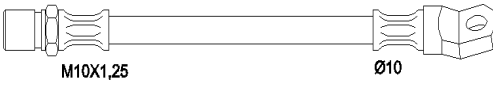
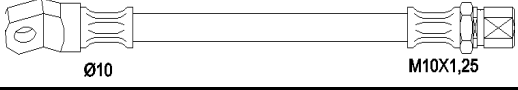
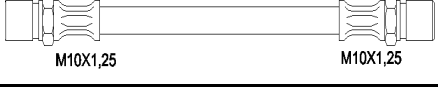
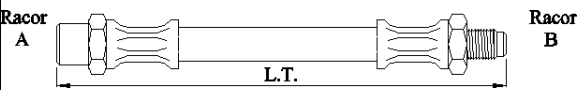
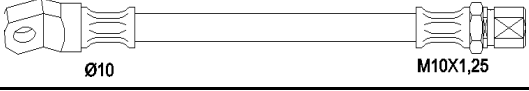
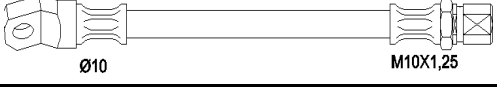
9-5 YS3E								
3.0TiD	07/01>	D	64156			445		
		T	62037	211	211	235		
3.0 V6t	10/98>	D	64156			445		
		T	62037	211	211	235		
SAAB								
	<i>Fecha Date</i>	<i>Eje Axle</i>	<i>Referencia Reference</i>	<i>Racor A Fitting</i>	<i>Racor B Fitting</i>	<i>LT</i>		
90								
2.0	09/84>08/87	D	62004			265		
2.0	89>94	T	63070			323		
99								
2.0	09/75>08/87	D	62004			265		
2.0	09/75>08/87	T	63070			323		
900								
	01/86>12/93	D	62004			265		
	01/95>12/03	T	62007			245		
900 I								
<i>Todos modelos</i>	01/80>11/93	D	63054			322		
<i>Todos modelos</i>	01/80>11/93	T	61004			194		

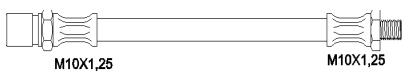
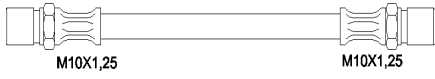
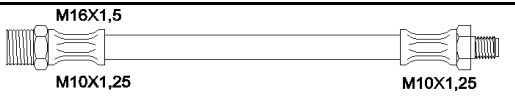
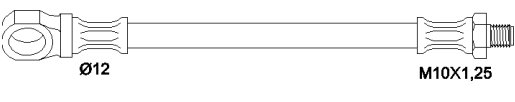
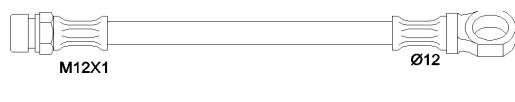
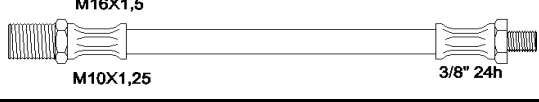
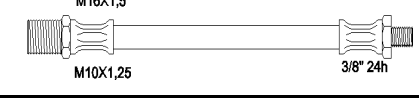
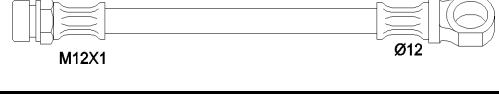
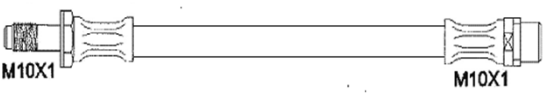
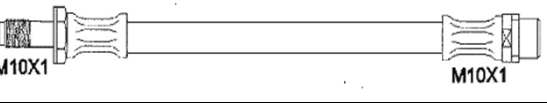
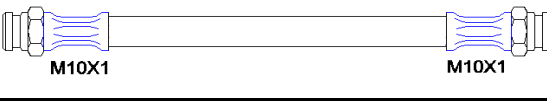
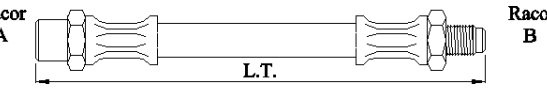
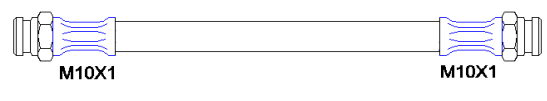
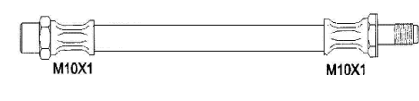
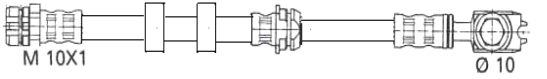

Todos modelos	01/80>11/93	T	63070			323	
900 II							
Todos modelos	08/93>	D	63247		211	340	
Todos modelos	08/93>	TI	62007			245	
Todos modelos	08/93>	TI	62197	211	237	242	
Todos modelos	08/93>	TD	62080			244	
SAAB							
	<i>Fecha Date</i>	<i>Eje Axle</i>	<i>Referencia Reference</i>	<i>Racor A Fitting</i>	<i>Racor B Fitting</i>	<i>LT</i>	
900 II							
Todos modelos	08/93>	TD	62197	211	237	242	
9000							
Todos modelos	05/85>07/98	T	63080			353	
Todos modelos	94>	D	65018			555	
SEAT							
	<i>Fecha Date</i>	<i>Eje Axle</i>	<i>Referencia Reference</i>	<i>Racor A Fitting</i>	<i>Racor B Fitting</i>	<i>LT</i>	
124							
Todos modelos	1978>	D	62163	051	132	285	
		T	61590	028	138	170	
		I	62410	028	028	200	
127 -128 (FURA)							

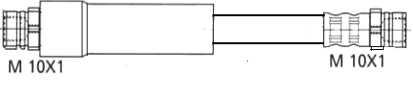
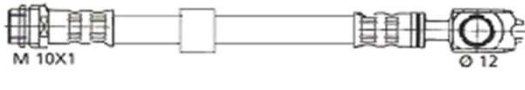
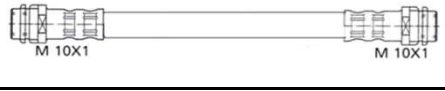
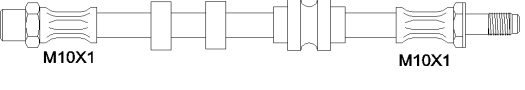

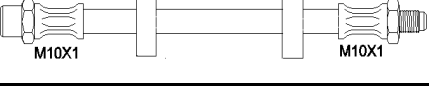
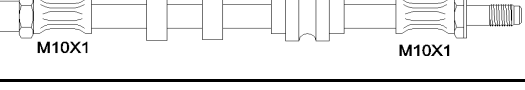
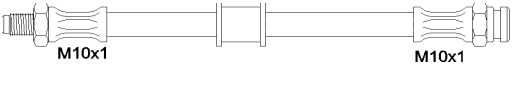
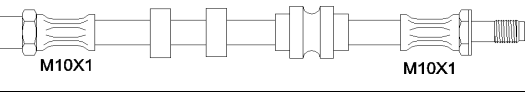
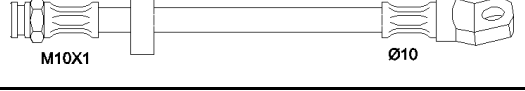
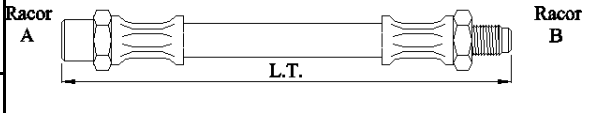
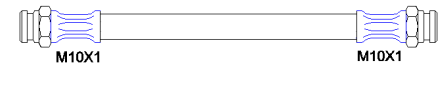
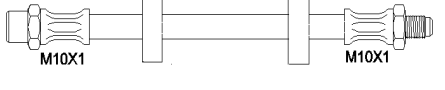
Todos modelos	1971>	D	62009	051	132	312	
		T	62008	051	132	280	
131							
Todos modelos 1430	1982>	D	62009	051	132	312	
		T	61590	028	138	170	
		I	63015	028	179	305	
Todos modelos 1800, 2000 Supermirafiori, Diplomatic	>1982	D	62009	051	132	312	
		T	63015	028	179	305	
Todos modelos 1800, 2000 Supermirafiori, Diplomatic	1982>83	D	63081	187	191	358	
131							
Todos modelos 1800, 2000 Supermirafiori, Diplomatic	1982>83	T	63082	187	191	350	
Todos modelos 131	1983>	D	63081	187	191	358	
		T	64066	187	191	440	
SEAT							
	Fecha Date	Eje Axle	Referencia Reference	Racor A Fitting	Racor B Fitting	LT	
132							
Todos modelos	1971>77	D	63007	051	132	380	
		T	61590	028	138	170	
		I	63015	028	179	305	
133							



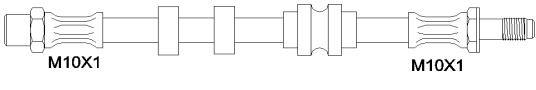
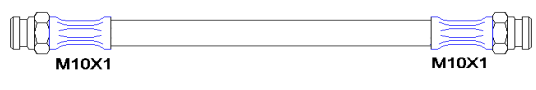
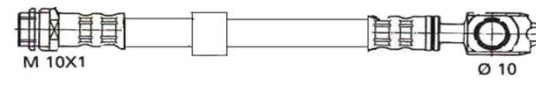
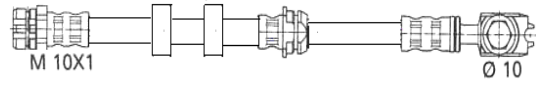

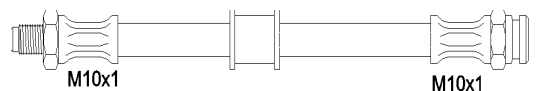
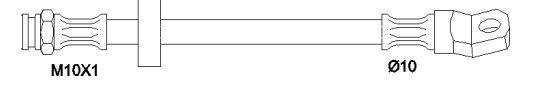
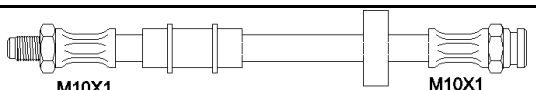
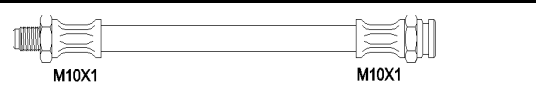
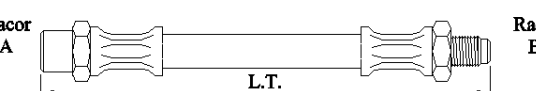
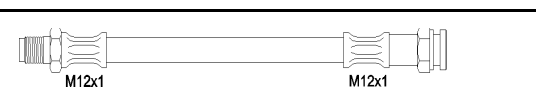
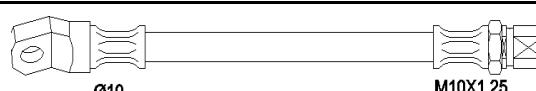
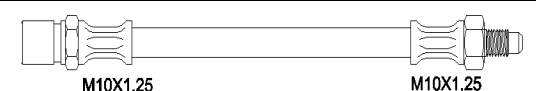
Todos modelos excepto E		D	63041	028	051	350	
Todos modelos E		D	62163	051	132	285	
Todos modelos		T	62340	028	028	213	
600							
Todos modelos N, D, E		D	63172	051	053	302	
		T	62140	053	053	224	
Ultimas series		D	63281	028	051	312	
Ultimas series		T	62340	028	028	213	
850							
Todos modelos N		D	63281	028	051	312	
Todos modelos N (Coupe) E		D	62163	051	132	285	
Todos modelos		T	62340	028	028	213	
SEAT							
							
	Fecha Date	Eje Axle	Referencia Reference	Racor A Fitting	Racor B Fitting	LT	
1200							
Todos modelos		D	62009	051	132	312	
		T	62008	051	132	280	
1430							
Todos modelos	1973>	D	62163	051	132	285	

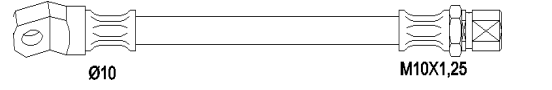
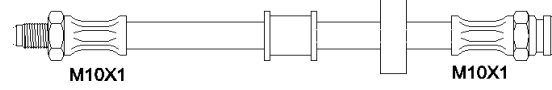

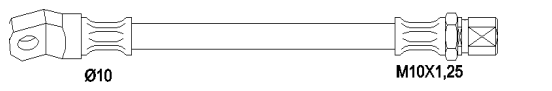
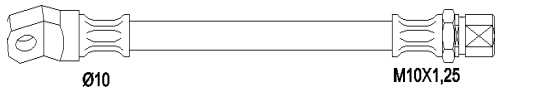
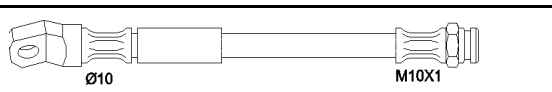
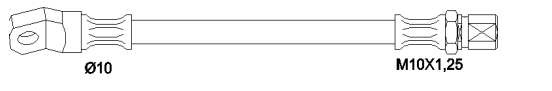
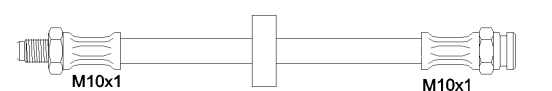
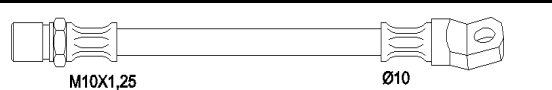
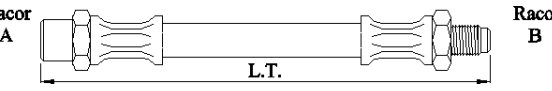
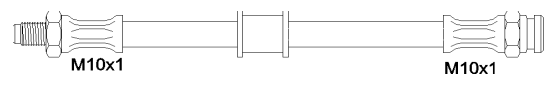
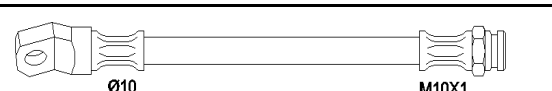
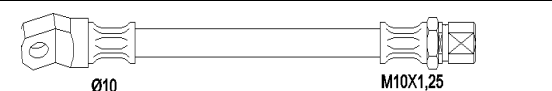
		T	61590	028	138	170	
		I	62410	028	028	200	
1400 / 1500							
1400 C, 1500 freno de tambor		D	63175	053	059	312	
		T	63170	047	059	353	
		E	63171	048	049	323	
1500 freno de disco		D	64270	127	138	446	
		T	61580	127	138	183	
		E	63171	048	049	323	
ALHAMBRA							
Todos modelos excepto 1.8T 20V, 1.9TDI (90>120CV)	1996>00	D	64168	244	253	498	
Todos modelos 1.8T 20V, 1.9TDI (90>120CV) Chasis > 7M1570000	2001>02	D	64168	244	253	498	
Todos modelos 1.8T 20V, 1.9TDI (90>120CV) Chasis 7M1570000>	2001>	D	64233	191	191	477	
SEAT							
	Fecha Date	Eje Axle	Referencia Reference	Racor A Fitting	Racor B Fitting	LT	
ALHAMBRA							
Lado chasis	96>00	T	64171	191	191	400	
Lado rueda	96>00	T	61181	186	244	190	
ALTEA							
Todos modelos		D	65034	253	275	572	

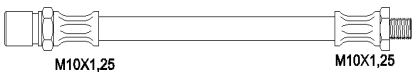
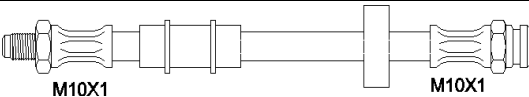
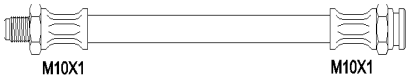
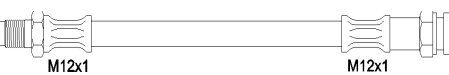
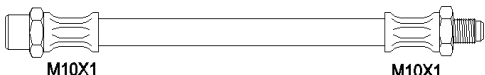
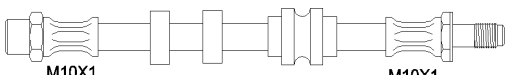

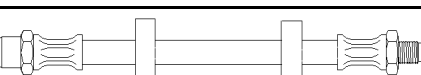
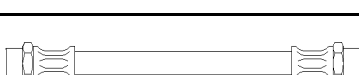
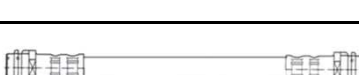
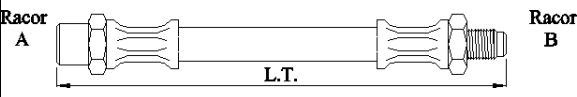
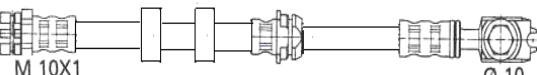

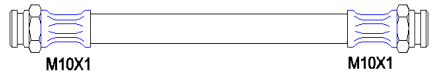
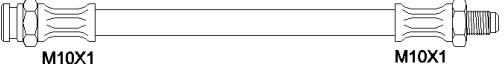
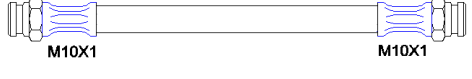
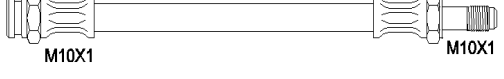
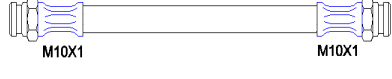

		T	62014	253	253	260	
AROSA							
Todos modelos	05/97>	D	64165			408	
	05/97>	T	62174	274	274	168	
CORDOBA							
Todos modelos	1993>	D	64144	186	244	485	
Lado chasis	1993>99	T	61096	191	191	160	
Lado rueda	93>99	T	61200	186	187	185	
Todos modelos	1999>	D	64144	186	244	485	
IBIZA							
Todos modelos	1984>93	D	64044	187	191	438	
Todos modelos	1993>99	D	64144	186	244	485	
Todos modelos	1984>93	T	63066	191	213	313	
SEAT							
	Fecha Date	Eje Axle	Referencia Reference	Racor A Fitting	Racor B Fitting	LT	
IBIZA							
Todos modelos lado chasis	93>99	T	61096	191	191	160	
Todos modelos lado rueda	93>99	T	61200	186	187	185	
Todos modelos	1999>	T	62174	274	274	168	
INCA							

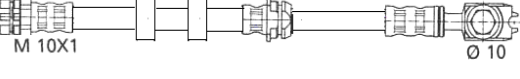
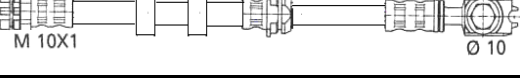
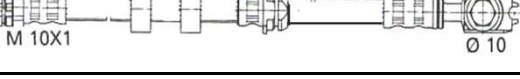
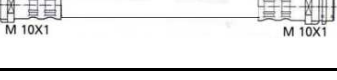
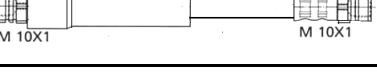
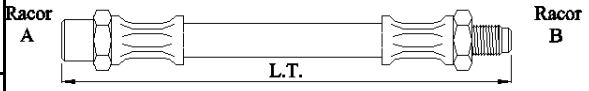
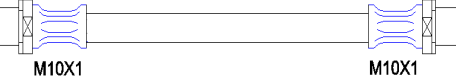
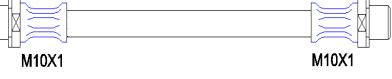
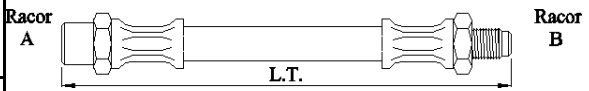
Todos modelos	>D11/95	D	64144	186	244	485	
INCA	>D11/95	T	64228	191	191	430	
LEON							
Todos modelos	>2005	D	64159	274	275	435	
Todos modelos	2005>	D	65034	253	275	572	
Todos modelos	>2005	T	62174	253	253	168	
Todos modelos	2005>	T	62014	253	253	260	
MALAGA							
Todos modelos	1985>	D	64044	187	191	438	
		T	63066	191	213	313	
MARBELLA							
Todos modelos	1986>	D	64067	187	191	464	
	86>	TD	62046	187	191	287	
SEAT							
	Fecha Date	Eje Axle	Referencia Reference	Racor A Fitting	Racor B Fitting	LT	
MARBELLA							
Todos modelos	86>	TI	62183	152	243	282	
PANDA 35 / 45							
Todos modelos	>1983	D	64058	051	132	433	
	>83	T	63042	028	179	350	

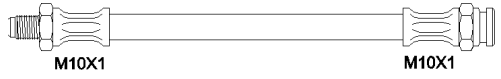
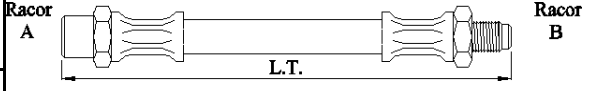
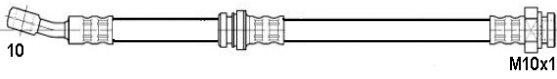

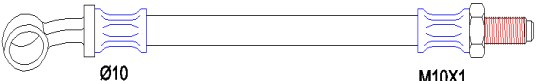
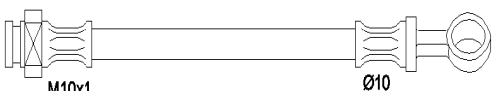
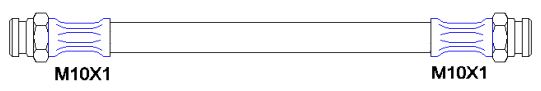
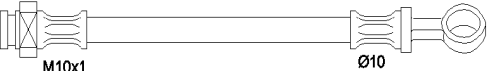
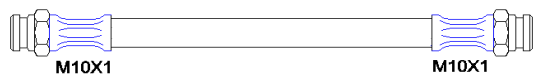
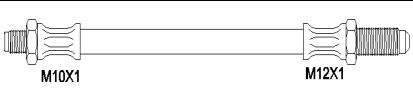
PANDA TRANS							
Todos modelos	>1983	D	64058	051	132	433	
	>83	T	62009	051	132	312	
Todos modelos	1983>	D	64032	187	191	464	
		T	64046	187	191	287	
RITMO							
Todos modelos	1979>83	D	62009	051	132	312	
		T	62009	051	132	312	
		T	62055	051	191	296	
RONDA							
Todos modelos rosca 10X1,25	>1982	D	62009	051	132	312	
Todos modelos rosca 10X1	1982>83	D	63062	187	191	355	
Todos modelos rosca 10X1,25		T	62027	028	051	275	
SEAT							
	Fecha Date	Eje Axle	Referencia Reference	Racor A Fitting	Racor B Fitting	LT	
RONDA							
Todos modelos rosca 10X1	1983>	D	64044	187	191	438	
Todos modelos rosca 10X1	83>	T	62034	051	191	295	
SPORT							
Todos modelos 1800		D	62163	051	132	285	

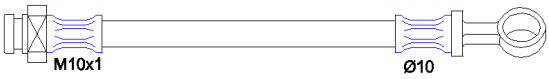
		<i>T</i>	61590	028	138	170	
TERRA							
<i>Todos modelos</i>	1986>	<i>D</i>	64067	187	191	464	
	86>	<i>TD</i>	62046	187	191	287	
	86>	<i>TI</i>	62183	152	243	282	
TOLEDO							
<i>Todos modelos chasis >ZD342000</i>	1991>94	<i>D</i>	63286	186	187	342	
<i>Todos modelos chasis ZD342001></i>	1991>98	<i>D</i>	64195	186	244	360	
<i>Todos modelos</i>	1998>02	<i>D</i>	64159	274	275	435	
<i>Todos modelos</i>	1991>94	<i>T</i>	61200	186	187	185	
<i>Todos modelos</i>	1994>98	<i>T</i>	61034	186	186	187	
<i>Todos modelos</i>	1998>02	<i>T</i>	62174	274	274	168	
SKODA							
							
	<i>Fecha Date</i>	<i>Eje Axle</i>	<i>Referencia Reference</i>	<i>Racor A Fitting</i>	<i>Racor B Fitting</i>	<i>LT</i>	
FABIA							
<i>Todos modelos</i>	1999<	<i>D</i>	65140	253	275	555	
		<i>T</i>	62174	274	274	168	
FAVORIT							
<i>1.3 (Berlina Pick Up, SW)</i>	1989>97	<i>D</i>	63046	187	191	365	

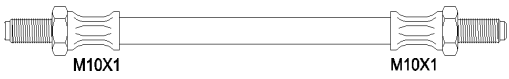
		T	62025	191	191	262	
FELICIA							
Todos modelos	>1995	D	63046	187	191	365	
		T	62025	191	191	262	
Todos modelos	1995>	D	63324	191	244	365	
		T	61182	191	191	195	
OCTAVIA							
Todos modelos	09/96>00	D	64159	274	275	435	
Todos modelos (-ABS)	2000>03	D	64159	274	275	435	
Todos modelos (+ABS)	2000>03	D	65036	253	275	580	
Todos modelos	2004>	D	65034	253	275	572	
	09/96>04	T	62174	274	274	168	
	2004>	T	62014	253	253	260	
SKODA							
	Fecha Date	Eje Axle	Referencia Reference	Racor A Fitting	Racor B Fitting	LT	
SUPER B							
		D	63316	253	253	317	
		T	62100	253	253	202	
SKODA							
	Fecha Date	Eje Axle	Referencia Reference	Racor A Fitting	Racor B Fitting	LT	

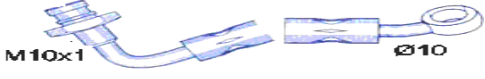
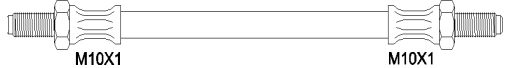
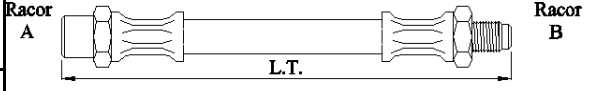
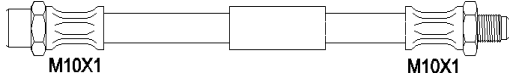
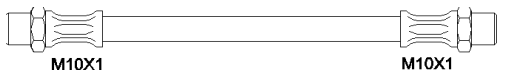
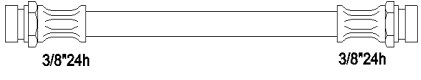
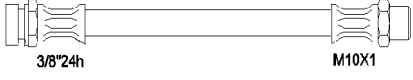
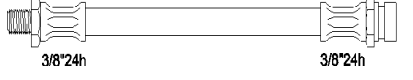
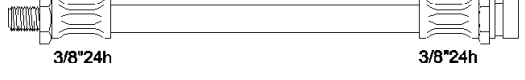
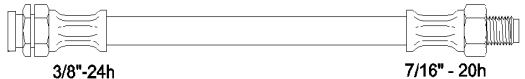
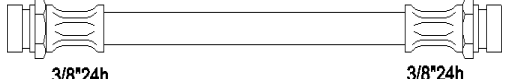
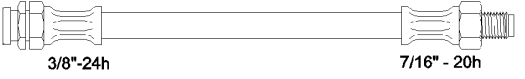
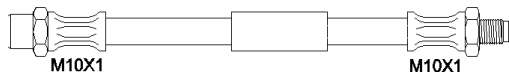
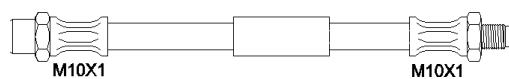
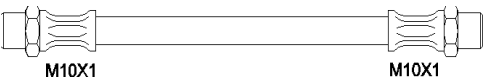

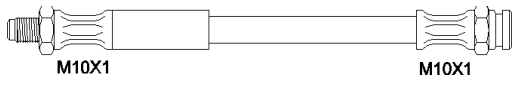
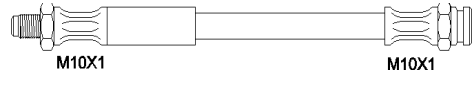
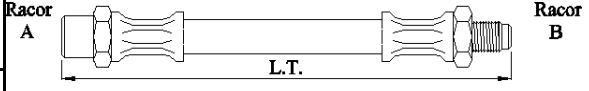
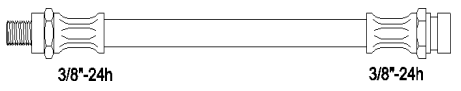
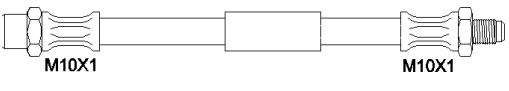
SMART								
Cabrio, Citi Coupe, Roadster		D	63089	187	191	337		
		SUZUKI						
	<i>Fecha Date</i>	<i>Eje Axle</i>	<i>Referencia Reference</i>	<i>Racor A Fitting</i>	<i>Racor B Fitting</i>	<i>LT</i>		
BALENO								
Todos modelos		1995>	D	64230	156	223	410	
			T	62111	233	233	244	
SJ410								
Todos modelos (Santana)		1989>91	D	63196	156	223	300	
Freno de disco		1991>	D	63254	232	217	300	
		>1991	T	63325	233	233	300	
SJ413								
Samurai		1985>	D	63254	232	217	300	
		85>	T	63325	233	233	300	
		85>	I	61032	187	215	175	
Samurai LWD		90>	T	63086	187	223	395	
VITARA								
1.9D		1996>	DD	65125	232	217	530	
			DI	65126			737	
2.0		1990>	D	65126			737	
			T	63221	223	223	340	

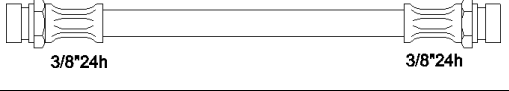
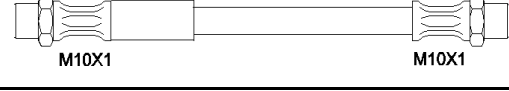
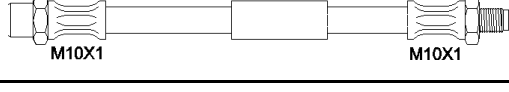
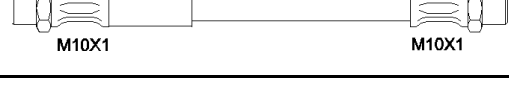
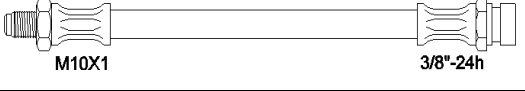
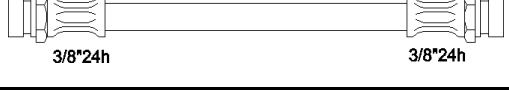
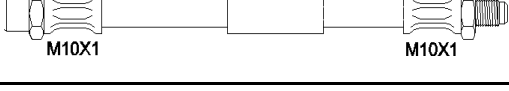
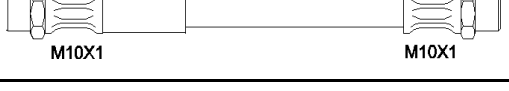
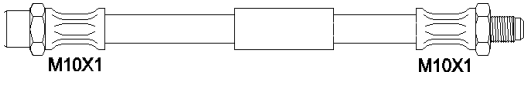
Santana 1.6, 1.9D, 1.9TD	1985>	D	65126			737	
		T	63221	223	223	340	
TALBOT							
	Fecha Date	Eje Axle	Referencia Reference	Racor A Fitting	Racor B Fitting	LT	
150							
Todos modelos 150	>1980	D	63033	186	187	374	
		T	63034	186	186	330	
Todos modelos 160 /180		D	64007	158	158	260	
180 D		D	62033	158	186	262	
Todos modelos		T	63008	138	158	171	
Todos modelos		I	63009	138	158	355	
DODGE DART							
Dodge Dart		D	63283	121	122	350	
Dodge Parte 3700 Freno disco		D	63192	158	158	316	
Todos modelos		T	63282	121	122	360	
HORIZON							
Todos modelos	1978>86	D	63033	186	187	374	
Todos modelos		D	63031	186	187	374	
Todos modelos		T	63053	186	186	330	
SAMBA							

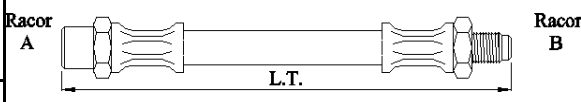
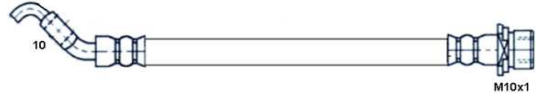
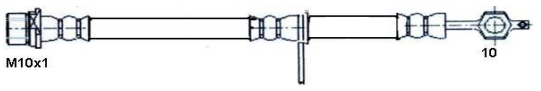
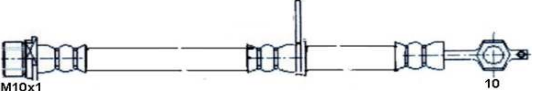
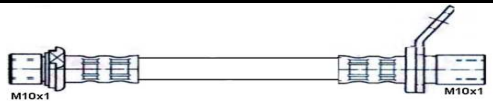
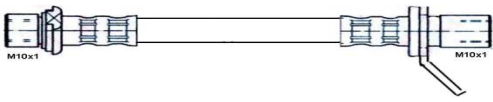
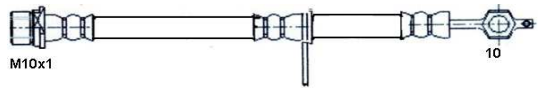
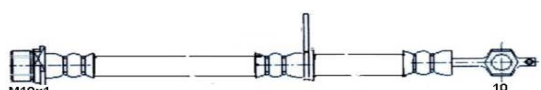
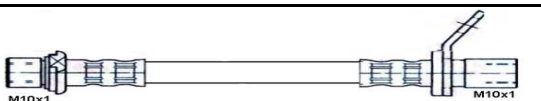
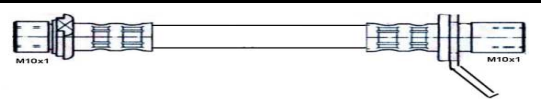
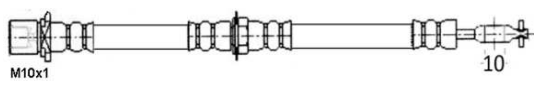
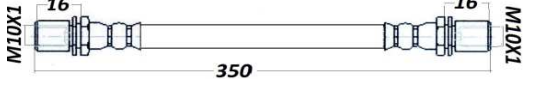
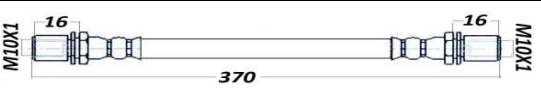
Todos modelos		D	63038	187	191	375	
SAMBA		T	62062	187	191	294	
TALBOT							
	Fecha Date	Eje Axle	Referencia Reference	Racor A Fitting	Racor B Fitting	LT	
SIMCA 900 / 1000							
Todos modelos	>1968	D	63167	157	158	296	
Todos modelos	1976>80	D	63033	186	187	374	
Todos modelos	>1968	T	63167	157	158	296	
Todos modelos	>1976	TD	62010	158	158	316	
Todos modelos	>1980	T	63032	186	186	330	
SIMCA 1100							
	1976>80	D	63033	186	187	374	
		T	63032	186	186	330	
SIMCA 1200							
Todos modelos	>1976	D	63011	187	158	372	
		T	62010	158	158	316	
Todos modelos	1976>	D	63031	186	187	374	
		T	63032	186	186	330	
SOLARA TAGORA							
Todos modelos	1980>84	D	63033	186	187	374	

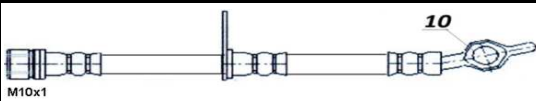
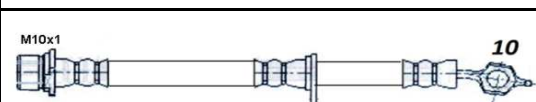
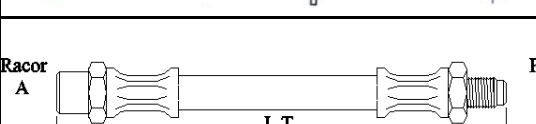
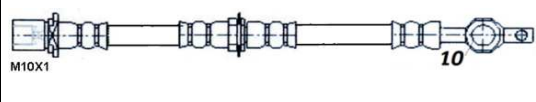
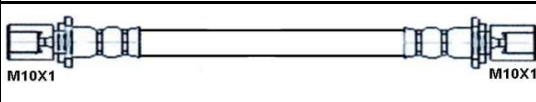
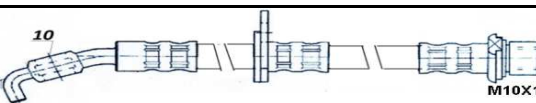
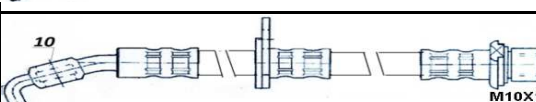
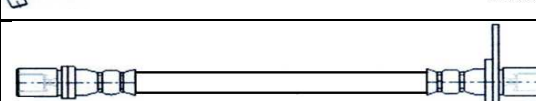
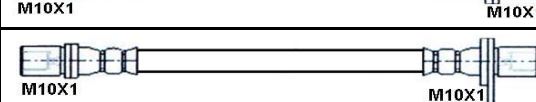
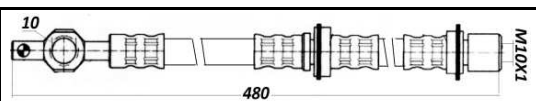
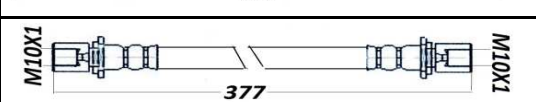
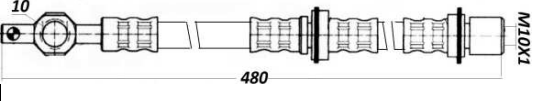
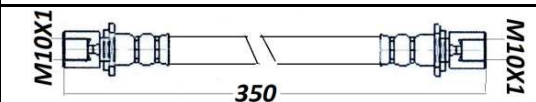
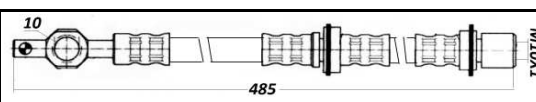
		T	63034	186	186	330	
TOYOTA							
							
	<i>Fecha Date</i>	<i>Eje Axle</i>	<i>Referencia Reference</i>	<i>Racor A Fitting</i>	<i>Racor B Fitting</i>	<i>LT</i>	
AURIS							
		T	62050			231	
AVENSIS							
<i>Todos modelos</i>	10/97>	DD	65005			532	
<i>Todos modelos</i>	10/97>	DI	65007			532	
<i>Todos modelos</i>	10/97>	TI	63003			378	
<i>Todos modelos</i>	10/97>	TD	63004			378	
AVENSIS ESTATE/WAGON							
<i>Todos modelos</i>	10/97>	DD	65005			532	
<i>Todos modelos</i>	10/97>	DI	65007			532	
<i>Todos modelos</i>	10/97>	TI	63003			378	
<i>Todos modelos</i>	10/97>	TD	63004			378	
CAMRY							
<i>Todos modelos</i>	10/82>07/88	D	65008			560	
<i>Todos modelos</i>	83>84	T	63005			350	
<i>Todos modelos</i>	85>91	T	63006			370	

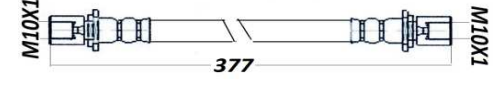
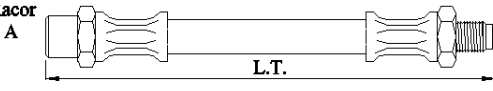
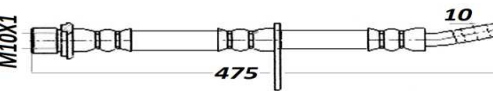
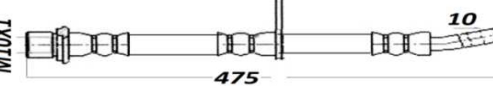
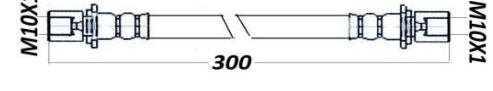
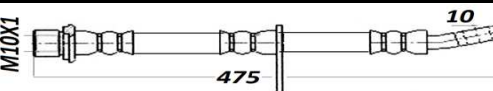
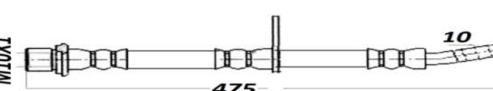
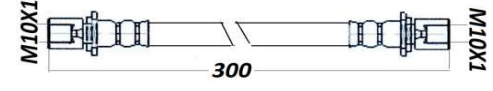
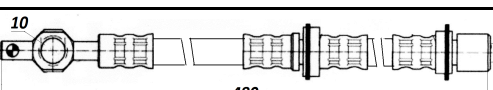
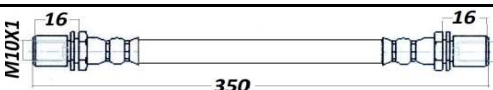
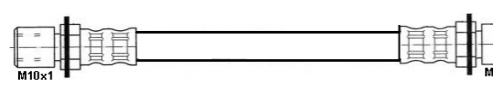
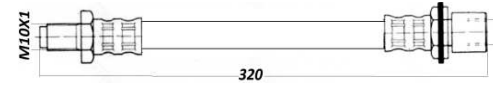



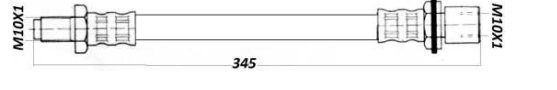
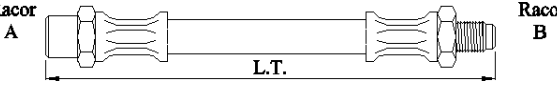
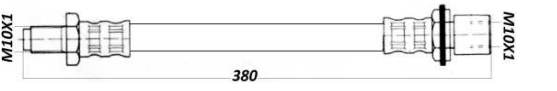
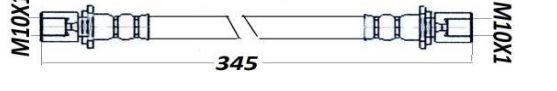
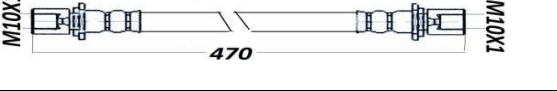
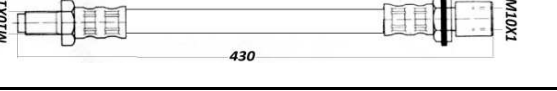
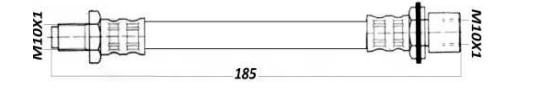
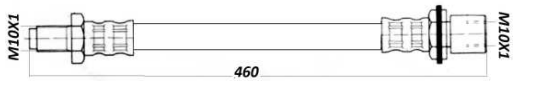
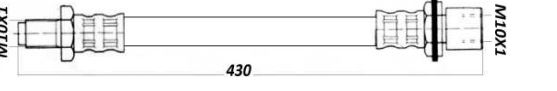
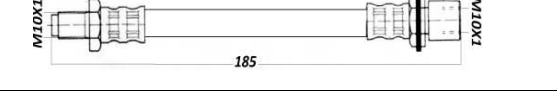
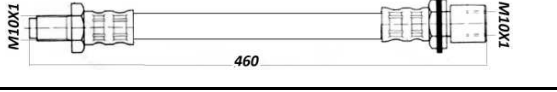
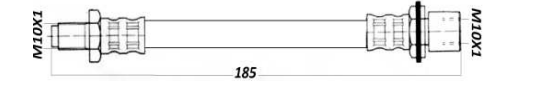
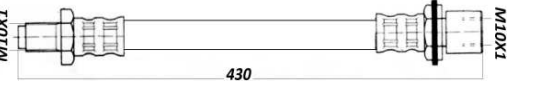
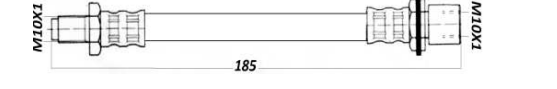

Todos modelos ABS (+)	12/92>	TI	64104			498	
Todos modelos ABS (+)	12/92>	TD	64105			498	
TOYOTA							
	Fecha Date	Eje Axle	Referencia Reference	Racor A Fitting	Racor B Fitting	LT	
CARINA II							
1.6, 1.8, Gli, 2.0 D	12/87>03/92	D	64047			494	
1.6, 1.8, Gli, 2.0 D	12/87>03/92	T	63014			370	
CARINA E							
Todos modelos	04/92>09/97	DD	65009			537	
Todos modelos	04/90>09/97	DI	65011			537	
Todos modelos	04/90>09/97	TD	63016			356	
Todos modelos	04/90>09/97	TI	63017			356	
CELICA (T16)							
1.6, 1.6 GT 2.0, 2.0 GT	04/86>08/90	D	64042			480	
1.6, 1.6 GT 2.0, 2.0 GT	04/86>08/90	T	63018			377	
COROLLA (E8)							
1.3, 1.6, 1.8D	06/83>08/87	D	64042			480	
1.3, 1.6, 1.8D	06/83>08/87	T	63019			350	
COROLLA (E9)							
1.3, 1.6, 1.8D	08/87>06>93	D	64060			485	



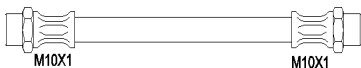
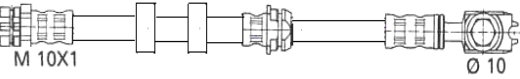
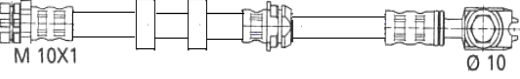

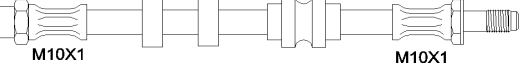
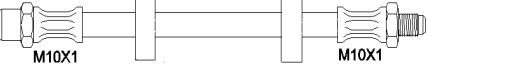
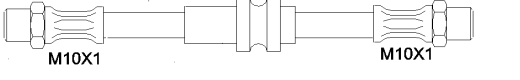
1.3, 1.6, 1.8D	08/87>06>93	T	63006			377	
TOYOTA							
	Fecha Date	Eje Axle	Referencia Reference	Racor A Fitting	Racor B Fitting	LT	
COROLLA (E10)							
1.3, 1.6, 2.0 D	07/92>04/97	DD	64061			475	
1.3, 1.6, 2.0 D	07/92>04/97	DI	64062			475	
1.3, 1.6, 2.0 D	07/92>04/97	T	63030			300	
COROLLA (E11)							
1.4 D, 1.6 D, 2.0 D	04/97>02/00	DD	64063			475	
1.4 D, 1.6 D, 2.0 D	04/97>02/00	DI	64070			475	
1.4 D, 1.6 D, 2.0 D	04/97>02/00	T	64090			300	
CORONA							
1.8, 2.0D	01/82>12/84	D	64042			480	
1.8, 2.0D	01/82>12/84	T	63005			350	
HIACE II (H5)							
1.8, 2.0, 2.2D, 2.4D	03/83>11/89	D	63123			305	
1.8, 2.0, 2.2D, 2.4D	03/83>11/89	T	63122			320	
HIACE III (H10)							
2.0, 2.4, 2.4D	08/89>08/95	DD	63121			355	

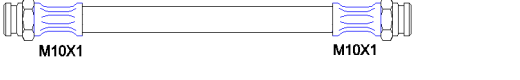
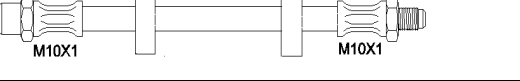
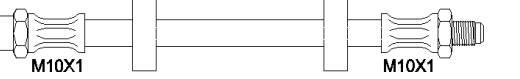
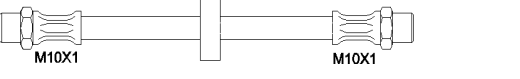
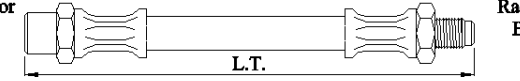
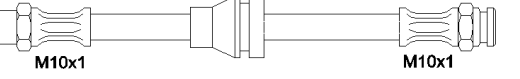



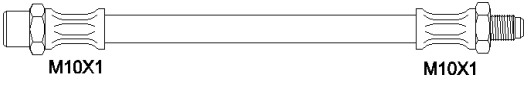

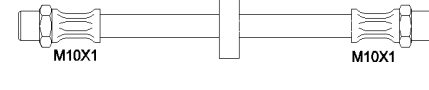
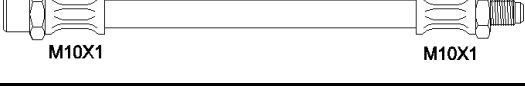
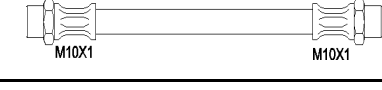
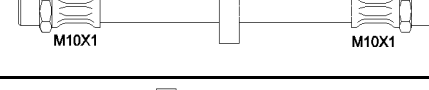
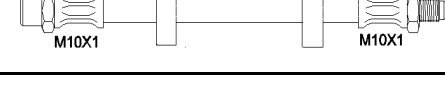
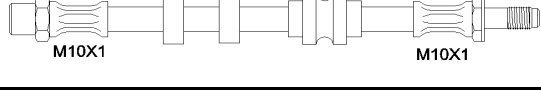
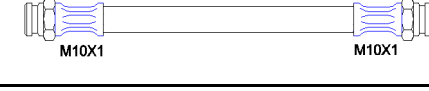
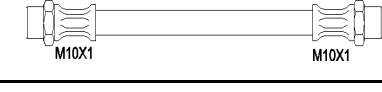
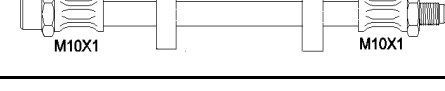
2.0, 2.4, 2.4D	08/89>08/95	DI	63115			355	
2.0, 2.4, 2.4D	08/89>08/95	E	63114			345	
TOYOTA							
	Fecha Date	Eje Axle	Referencia Reference	Racor A Fitting	Racor B Fitting	LT	
HIACE III (H10)							
2.0, 2.4, 2.4D	08/93>08/95	E	63039			380	
HILUX PICKUP (N)							
1.8, 2.4D	03>89>	D	63005			345	
2.0, 2.2 4WD, 2.4 4WD, 2.4D 4WD	08/88>	D	64175			470	
Todos modelos	08/88>	E	64100			430	
LAND CRUISER							
2.4 D	11/84>01/95	D	61003			185	
2.4 D	>07/90	T	64110			460	
2.4 D	08/90>95	T	64100			430	
2.5 D	11/84>12/89	D	61003			185	
2.5 D	11/84>12/89	T	64110			460	
LAND CRUISER							
3.0 D	01/90>03/96	D	61003			185	
3.0 D	01/90>03/96	T	64100			430	
3.4 D	08/80>12/89	D	61003			185	

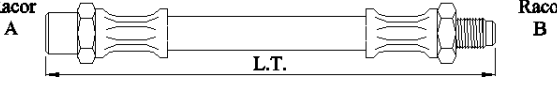
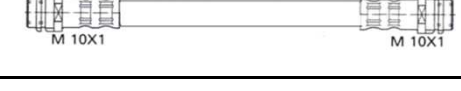

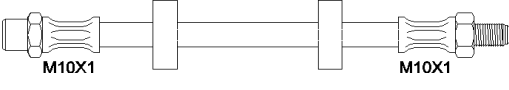
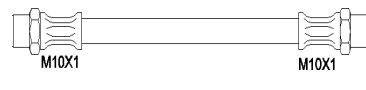
3.4 D	08/80>12/89	T	64100			430	
3.4 D	08/80>12/89	T	64110			460	
TOYOTA							
	Fecha Date	Eje Axle	Referencia Reference	Racor A Fitting	Racor B Fitting	LT	
LAND CRUISER							
4.0	9/88>01/90	D	61003			185	
4.0 D	9/88>01/90	T	63039			380	
4.0 D	10/82>12/89	D	61003			185	
4.0 D	10/82>12/89	T	64110			460	
4.0 D	10/82>12/89	T	63039			380	
4.0 D	08/80>10/84	E	62079			280	
4.0 D	08/80>10/84	T	64100			430	
4.2, 4.2 D,	08/80>10/84	D	61003			185	
4.2, 4.2 D,	08/80>10/84	E	62079			280	
4.2, 4.2 D,	08/80>10/84	T	64100			430	
4.2, 4.2 D,	08/80>10/84	T	63039			380	
4.2 D	01/90>01/95	D	61003			185	
4.2 D	01/90>01/95	T	64100			430	
RAV4							
2.0	04/94>04/00	DI	64161			480	

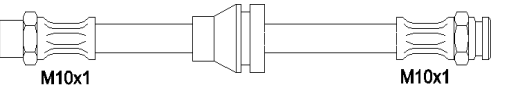
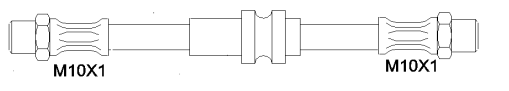
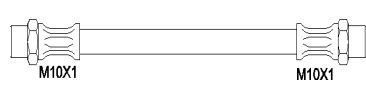
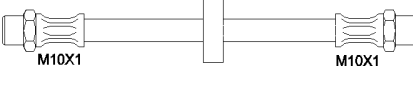
2.0	04/94>04/00	DD	64162			480	
TOYOTA							
	<i>Fecha Date</i>	<i>Eje Axle</i>	<i>Referencia Reference</i>	<i>Racor A Fitting</i>	<i>Racor B Fitting</i>	<i>LT</i>	
YARIS							
Todos modelos	08/99>	DI	65012			560	
Todos modelos	08/99>	DD	65013			560	
Todos modelos	08/99>	T	63050			318	
VIASA/WILLIS							
	<i>Fecha Date</i>	<i>Eje Axle</i>	<i>Referencia Reference</i>	<i>Racor A Fitting</i>	<i>Racor B Fitting</i>	<i>LT</i>	
VIASA / WILLIS							
Willis		D	62760	007	010	310	
		T	64820	007	010	432	
Jeep Willis		D	61020	007	007	178	
		T	64520	007	010	402	
VOLKSWAGEN							
	<i>Fecha Date</i>	<i>Eje Axle</i>	<i>Referencia Reference</i>	<i>Racor A Fitting</i>	<i>Racor B Fitting</i>	<i>LT</i>	
BORA							
Todos modelos excepto 4X4	1998>	D	64159	275	274	468	
Todos modelos lado chasis excepto 4X4		T	62174	253	253	168	

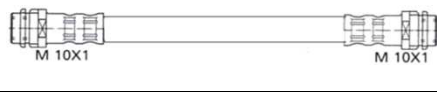
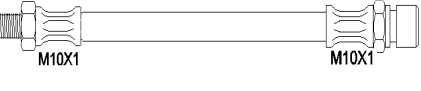
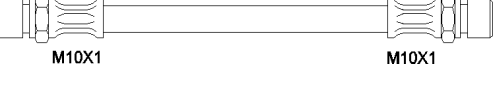
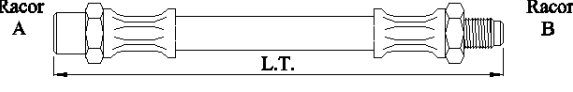
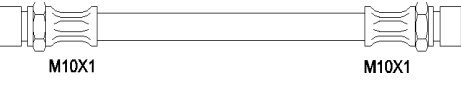

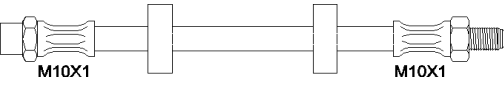
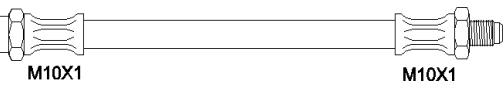
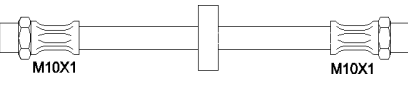
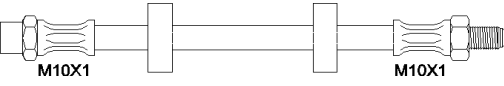
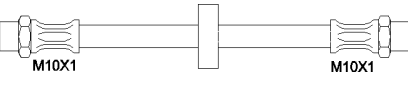
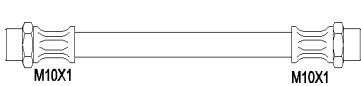
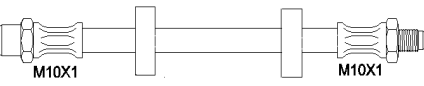
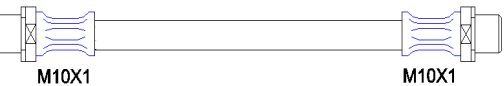
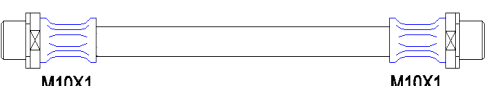

Todos modelos lado rueda 4X4	98>	T	61034	186	186	187	
Modelos 4X4		D	65036	253	275	580	
		T	65036	253	275	580	
CADDY							
Todos modelos	1982>	D	63147	186	187	343	
Todos modelos	1995>	D	64144	186	244	485	
		T	61200	186	187	185	
CORRADO							
CORRADO todos excepto 2.9 VR6	>07/1991	D	63401	186	253	355	
CORRADO todos excepto 2.9 VR6	08/1991>	D	64144	186	244	485	
Todos lado chasis	91>95	T	61096	191	191	160	
Todo lado rueda	91>95	T	61200	186	187	185	
DERBY							
Todos modelos	1977>81	D	63094	186	187	314	
		T	62048	186	186	210	
VOLKSWAGEN							
	Fecha Date	Eje Axle	Referencia Reference	Racor A Fitting	Racor B Fitting	LT	
GOLF I							
Todos modelos	1974>76	D	63279	186	191	310	
Todos modelos	1977>80	D	63219	186	187	350	

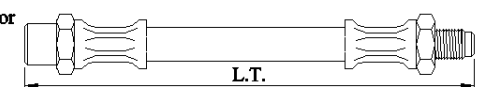
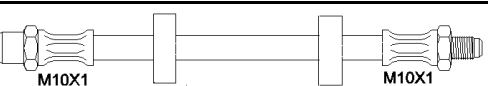
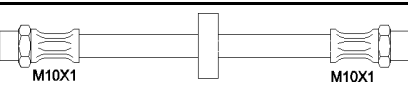
Todos modelos	1981>83	D	63278	186	187	335	
Todos modelos		D	62097	186	187	210	
Todos modelos	1978>83	T	62048	186	186	210	
GOLF II							
Todos modelos	1983>91	D	63278	186	187	335	
Todos modelos	1983>91	T	61034	186	186	187	
1.8 GTI	1988>91	T	62048	186	186	210	
1.8 GTI G60 Lado rueda		T	61200	186	187	185	
GOLF III							
Todos modelos	10/91>97	D	64144	186	244	485	
Todos modelos		T	61096	191	191	160	
Todos modelos		T	61034	186	186	187	
Todos modelos Lado rueda		T	61200	186	187	185	
GOLF IV							
Todos modelos	1997>	D	64159	274	275	435	
VOLKSWAGEN							
	Fecha Date	Eje Axle	Referencia Reference	Racor A Fitting	Racor B Fitting	LT	
GOLF IV							
Todos modelos	98>	T	62174	253	253	168	
JETTA I							
	Fecha	Eje	Ref.	A	B	LT	

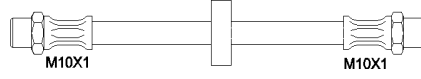
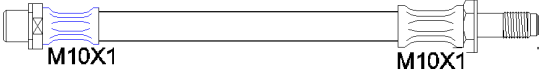
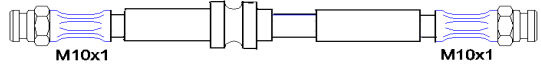
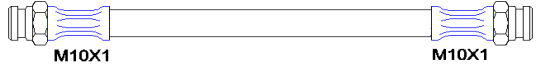

Todos modelos	1978>84	D	63147	186	187	343	
Todos modelos		T	61034	186	186	187	
JETTA II							
Todos modelos	1985>91	D	63147	186	187	343	
Todos modelos	1992>	D	63279	186	191	310	
G60	1990>92	D	63401	186	253	355	
Todos modelos lado chasis		T	61034	186	186	187	
		T	62048	186	186	210	
Todos modelos lado rueda		T	61200	186	187	185	
LUPO							
Todos modelos		D	64165			408	
		T	62174	253	253	168	
NEW BEETLE							
Todos modelos	>1972	D	61203	187	216	185	
	1972>	D	63426	216	216	323	
VOLKSWAGEN							
	Fecha Date	Eje Axle	Referencia Reference	Racor A Fitting	Racor B Fitting	LT	
NEW BEETLE							
Todos modelos	1972>	T	62042	216	216	275	
	10/1998>	D	64159	275	274	468	

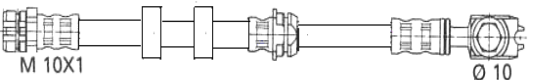
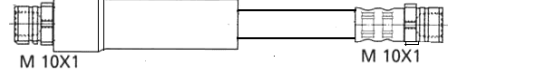
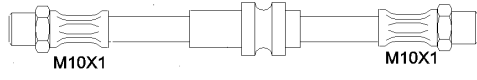
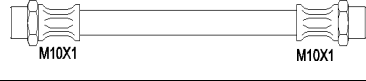
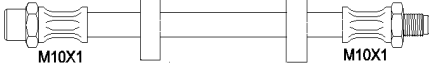
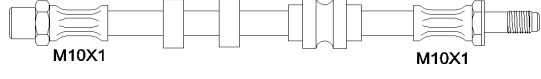
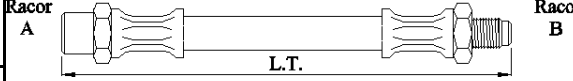
		T	62174	253	253	168	
PASSAT I 73>03/88							
Todos modelos (pinza ATE) Todos modelos (pinza TRW) Todos modelos	1973>88	D	63147	186	187	343	
	1973>88	D	62097	186	187	210	
	1973>88	T	62048	186	186	210	
PASSAT II 04/88>97							
Todos modelos Todos modelos Todos modelos Todos modelos Lado rueda	04/88>97	D	63147	186	187	343	
	1988>93	T	62048	186	186	210	
	1993>97	T	61034	186	186	187	
	85>86	T	61200	186	187	185	
PASSAT III 1996>							
Todos modelos	10/1996>	D	63316	253	253	317	
Todos modelos	10/1996>	T	62100	253	253	202	
Todos modelos >Chasis 3BX600000	10/1996>	T	62357	253	277	206	
VOLKSWAGEN							
							
	Fecha Date	Eje Axle	Referencia Reference	Racor A Fitting	Racor B Fitting	LT	
POLO I - II 1975>94							
Todos modelos	1975>94	D	63094	186	187	320	
		T	62048	186	186	210	

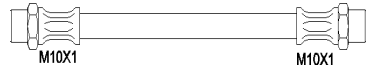
POLO III 1994>01							
Todos modelos (excepto Classic, Variant)	10/94>01	D	64165			408	
Todos modelos (excepto Classic, Variant) (-1.4 16V)		T	61096	191	191	160	
1.4 16V (-Classic, Variant)		T	61200	186	187	185	
Todos modelos Classic, Variant	11/95>01	D	64144	186	244	485	
Todos modelos Classic, Variant	11/95>01	T	61036	191	191	166	
POLO IV 2002							
Todos modelos	10/2001>	D	65140	253	275	555	
		T	62174	253	253	168	
SANTANA		Fecha	Eje	Ref.	A	B	LT
Todos modelos	1981>	D	63147	186	187	485	
		T	62048	186	186	210	
		T	61034	186	186	187	
SCIROCCO							
Todos modelos	1974>78	D	63219	186	187	350	
VOLKSWAGEN							
	Fecha Date	Eje Axle	Referencia Reference	Racor A Fitting	Racor B Fitting	LT	
SCIROCCO							
Todos modelos	1974>78	T	61034	186	186	187	
Todos modelos	1978>	D	63147	186	187	485	

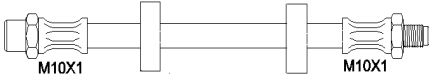
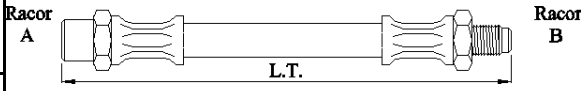
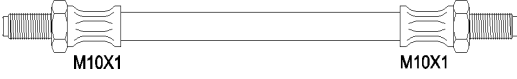
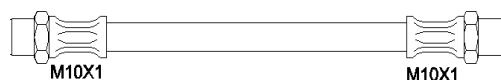
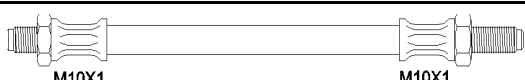
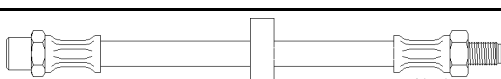
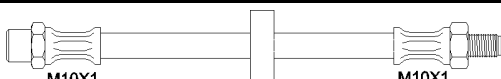
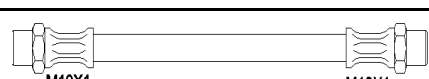
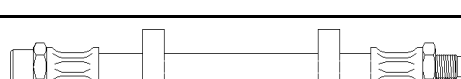
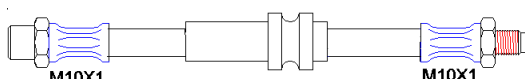
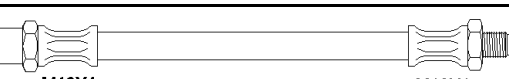
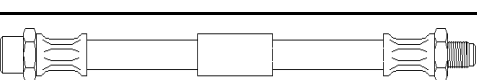
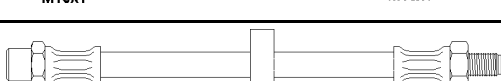
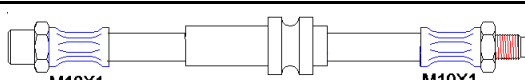
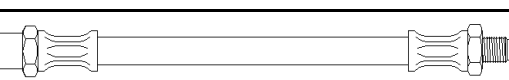
		T	62048	186	186	210	
SHARAN							
Todos modelos (excepto 2.8, 4x4)	1996>	D	64168	253	244	498	
	>2002	D	64233	191	191	477	
	Lado chasis	T	64171	191	191	400	
	Lado rueda	T	61181	186	244	190	
TOURAN							
	2003>	D	65034	253	275	572	
		T	62014	253	253	260	
TRANSPORTER T4							
Todos modelos	1991>95	D	63401	253	253	365	
	Lado chasis	T	61034	186	186	187	
	Lado rueda	T	61200	186	187	185	
VENTO							
Todos modelos	1992>	D	64144	186	244	485	
VOLKSWAGEN							
Fecha Date	Eje Axle	Referencia Reference	Racor A Fitting	Racor B Fitting	LT		
VENTO							
Todos modelos freno de tambor		T	61034	186	186	187	
	T. Modelos freno de disco lado chasis	T	61034	186	186	187	

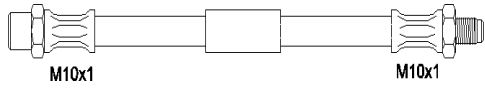
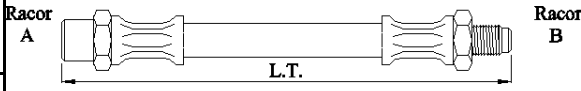
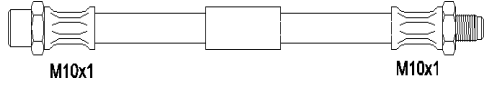
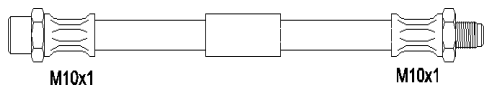
T. Modelos freno de disco lado rueda		T	61200	186	187	185	
VOLVO							
	Fecha Date	Eje Axle	Referencia Reference	Racor A Fitting	Racor B Fitting	LT	
240, 260							
Todos modelos	1975>77	D	63222	223	223	330	
Todos modelos	1977>	D	63212	186	186	310	
240, 260 según chasis	1977>	T	63223	187	223	337	
240, 260 según chasis	1977>	T	63225	186	187	335	
340, 360							
Todos modelos excepto 1.4	1975>91	D	63095	186	187	310	
Todos modelos excepto 1.4	1975>91	T	62176	186	186	258	
Modelo 1.4	1975>91	T	62035	186	187	275	
440							
Todos modelos	1989>97	D	64234	186	187	485	
Freno de tambor	1989>92	T	64210	186	187	410	
Freno de disco	1989>92	T	63213	186	187	330	
con ABS	1993>97	T	63095	186	187	310	
460							
	Fecha	Eje	Ref.	A	B	LT	
Todos modelos	90>97	D	64234	186	187	485	
Freno de tambor		T	64210	186	187	410	

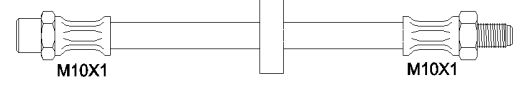
		T	63213	186	187	330	
	VOLVO						
	<i>Fecha Date</i>	<i>Eje Axle</i>	<i>Referencia Reference</i>	<i>Racor A Fitting</i>	<i>Racor B Fitting</i>	<i>LT</i>	
480							
<i>Todos modelos</i>	1986>95	D	64234	186	187	485	
		T	63213	186	187	330	
740 - 760 - 850 - 940 - 960							
<i>Todos modelos</i>	1982>	D	63224	186	187	370	
740, 760, 940, 960	82>	T	63225	186	187	335	
850	91>97	T	62076	186	186	225	